



FAGOR AUTOMATION

Digital servo drive system



Servo Drives Systems



The Fagor Automation's digital servo drive system is the perfect solution for the machine-tool manufacturer who requires smooth, fast and precise machining. 2 differentiated servo drive systems are available, the modular one and the compact one.

The modular system is the most appropriate for governing the spindle and the axes of the machine. It offers maximum efficiency using a single power supply for all the drive modules.

- **Axis control:** AXD drive **FKM / FXM motor**
- **Spindle control:** SPD drive **FM7 / FM9 motor**

The compact system is the most appropriate for governing independent axes. They are drives with an integrated power supply and may be connected directly to mains.

- **Axis control:** ACD drive **FKM / FXM motor**
- **Spindle control:** SCD drive **FM7 / FM9 motor**

FXM	Torque (Nm)	1.2 ... 4.1	2.6 ... 9.3	11.9 ... 25.9	20.8 ... 76.6
	Flange (mm)	80	95	130	180

FKM	Torque (Nm)	1.7 ... 3.2	6.3 ... 11.6	8.9 ... 23.5	68 ... 115
	Flange (mm)	80	110	130	230

FM7 E01	Power (kW)	3.7	5.5 ... 9	11 ... 22	22 ... 37	21.5 ... 60
	Flange (mm)	150	180	230	300	350
	Shaft height (mm)	100	112	160	180	225

FM9 E01	Power (kW)	55	71 ... 130
	Flange (mm)	300	450
	Shaft height (mm)	180	225

General characteristics

Interface	Sercos or analog
Velocity feedback	High resolution Sincos encoder
Protections	Over-voltage, over-current, over-speed, over-temperature, overload, etc.
Control	High speed spindles and built-in motors
Direct position feedback	Differential TTL, Vpp, distance-coded reference mark, FAGOR absolute

Model range

Power supplies-Modular system

MODEL	Non-regenerative		Regenerative		Regulated with energy regeneration			
	PS-65A	PS-25B4	XPS-25	XPS-65	RPS-20	RPS-45	RPS-75	RPS-80
Input voltage	Three-phase mains of 360 VAC to 506 VAC							
Voltage supply for the module control circuit	24 Vdc (between 21 & 28 Vdc)							
Output voltage (Power bus)	565 - 650 Vdc				600, 625 or 725 VDC. It is programmable.			
Rated (peak) output power	65 kW (195 kW, 1 s)	25 kW (75 kW, 1 s)	25 kW (55 kW, 1 s)	65 kW (108 kW, 1 s)	20 kW (26 kW, in S6)	45 kW (59 kW, in S6)	75 kW (97 kW, in S6)	80 kW (104 kW, in S6)
Rated (peak) output current	120 A (360 A, 1 s)	45 A (135 A, 1 s)	45 A (135 A, 1 s)	120 A (120 A, 1 s)	32 A (41.6 A, in S6)	72 A (95 A, in S6)	120 A (156 A, in S6)	128 A (166.5 A, in S6)
Output voltage for drive control signals	24 Vdc / 240 W		24 Vdc / 192 W					
Internal crowbar resistance (Ballast)/ Power	9 Ohms / 600 W	16,5 Ohms / 500 W	18 Ohms / 520 W	9 Ohms / 1800 W				
Rated regenerative power			20 kW	54 kW				
Associated chokes			Choke XPS-25	Choke XPS-65	Choke RPS-20	Choke RPS-45	Choke RPS-75-3	
Dimensions	Size 2	Size 1	Size 3	Size 4	Size 3	Size 5	Size 6	

Drives for synchronous and asynchronous motors - Modular system

MODEL	AXD (for axes)								SPD (for spindles)								
	1.08	1.15	1.25	1.35	2.50	2.75	3.100	3.150	1.25	1.35	2.50	2.75	2.85	3.100	3.150	3.200	3.250
I rated (A)	4	7.5	12.5	17.5	23.5	37.5	50	75									
I peak (0.5 s) (A)	8	15	25	35	47	75	100	150									
I rated (S1) at 4 kHz									16	23.1	31	42	50	70	90	121	135
I rated (S1) at 8 kHz									13	18	27	32	37	56	70	97	108
I S6 - 40% 4 kHz									20.8	30	40.3	54.6	65	91	117	157.3	175.5
I S6 - 40% 8 kHz									16.9	23.4	35.1	41.6	48.1	72.8	91	126.1	140.4
Voltage supply for control circuits	24 Vdc (between 21 & 28 Vdc)																
Consumption of control circuits	0.9 A			1.25 A			2 A		0.9 A			1.25 A			2 A		
Dimensions	Size 1			Size 2			Size 4		Size 1			Size 2			Size 4		

Drives for synchronous and asynchronous motors - Compact system

MODEL	ACD (for axes)				SCD (for spindles)			
	1.08	1.15	1.25	2.35	1.15	1.25	2.35	2.50
I rated (A)	4	7.5	12.5	17.5				
I peak (0.5 s) (A) 4 kHz	8	15	25	35				
I peak (0.5 s) (A) 8 kHz	8	15	19	35				
I max. (A) 4 kHz					10.6	17.5	28	38
I max. (A) 8 kHz					10.6	12.5	19.5	27.0
Input voltage	Three-phase mains of 360 VAC to 506 VAC							
Internal ballast resistor (Ohms)	75	75			75			
Power (W)	150	150			150			
Service voltage (output)	24 Vdc (5%), 110 mA							
Dimensions	Size 1			Size 2	Size 1		Size 2	

Accessory modules

Auxiliary power supply module, APS 24

It generates the 24 Vdc required by power supply and drive modules to supply their control circuits.



Input voltage	from 400 VAC - 10% to 460 VAC + 10% 50/60 Hz.
Mains consumption	0.72 A (400 VAC) 0.63 A (460 VAC)
Output voltage, maximum current	24 Vdc [5%] 10 A
Dimensions	Size 1

Resistor modules

They must be used with PS, XPS power supplies and with ACD, SCD compact drives.

They are designed to dissipate the excess energy generated while braking when it exceeds the one dissipated by the internal Ballast resistor.



Model	Ω	W
ER+TH-24 / 750	24	650
ER+TH-24 / 1100	24	950
ER+TH-18 / 1100	18	950
ER+TH-18 / 1800	18	1300
ER+TH-18 / 2200	18	2000
ER+TH-18 / 1100 + FAN	18	2000
ER+TH-18 / 1500 + FAN	18	3000
ER+TH-18 / 2200 + FAN	18	4000

Capacitor module CM 1.60

It stores the energy returned by the motors while braking when using PS (non-generative) power supplies.

It has a capacity of 4mF and it provides a maximum voltage of 797 Vdc at the power bus.



Mains filter

The European Directive 92/31/CE on electromagnetic compatibility requires inserting a mains filter between mains and the drive system (modular or compact).

Available models:



- MAIN FILTER 42A for "PS-25B4 / XPS-25 / RPS-20" power supplies
- MAIN FILTER 130A for "PS-65 / XPS-65 / RPS-45 / RPS-75" power supplies
- MAIN FILTER 180A for RPS-80 power supplies

Chokes for XPS power supplies.

When using regenerative power supplies (XPS) these chokes must be installed in the power regeneration circuit in order to comply with the established regulation.

Available models:

- CHOKE XPS-25
- CHOKE XPS-65



Chokes for RPS power supplies

Installing chokes is an absolute must when using RPS regenerative regulated power supplies and they must always be installed between the RPS power supply and the DLC mains filter.

- CHOKE RPS-20
- CHOKE RPS-45
- CHOKE RPS-75-3

Configuration of the drive modules

- Direct feedback (optional)**
 Feedback of the actual (real) position of an axis, usually by connecting a linear or rotary encoder.
- Encoder simulation (optional)**
 It provides a number of pulses per motor revolution that may be set by parameter (any value between 1 and 16,384 pulses/turn), programmable I/O, differential TTL.
- Motor feedback**
 It reads the signals coming from an encoder mounted on the motor to know the exact position and speed of the rotor.
- RS-232 C**
 To connect with a PC or the programming module for system parameter setting and monitoring (from 9600 to 19200 Bd).
- Digital sercos interface (optional)**
 Precise and efficient interface through optical fiber, using the SERCOS standard to transmit position, velocity and torque commands.
 The use of optical fiber ensures full immunity against noise and very simple wiring between modules.
- Digital CAN interface (optional)**
 Standard CAN communications interface to transmit position, velocity and torque commands.
- Analog interface (optional)**
 It offers two $\pm 10V$ analog inputs and two $\pm 10V$ analog outputs to connect the velocity commands from the CNC and monitor the internal parameters respectively. It also offers four inputs and four outputs, all of them digital and fully programmable.

Dimensions

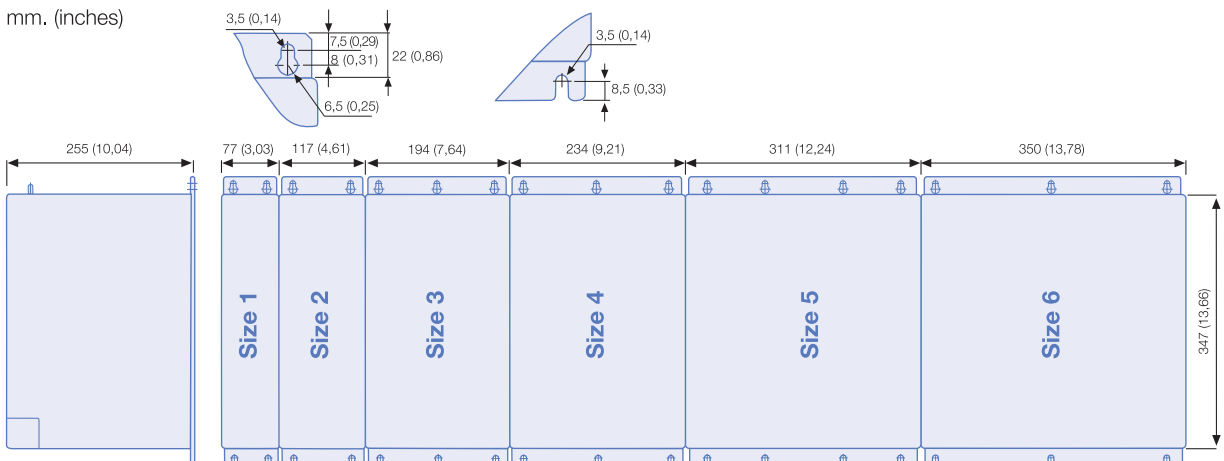

Electrical connection

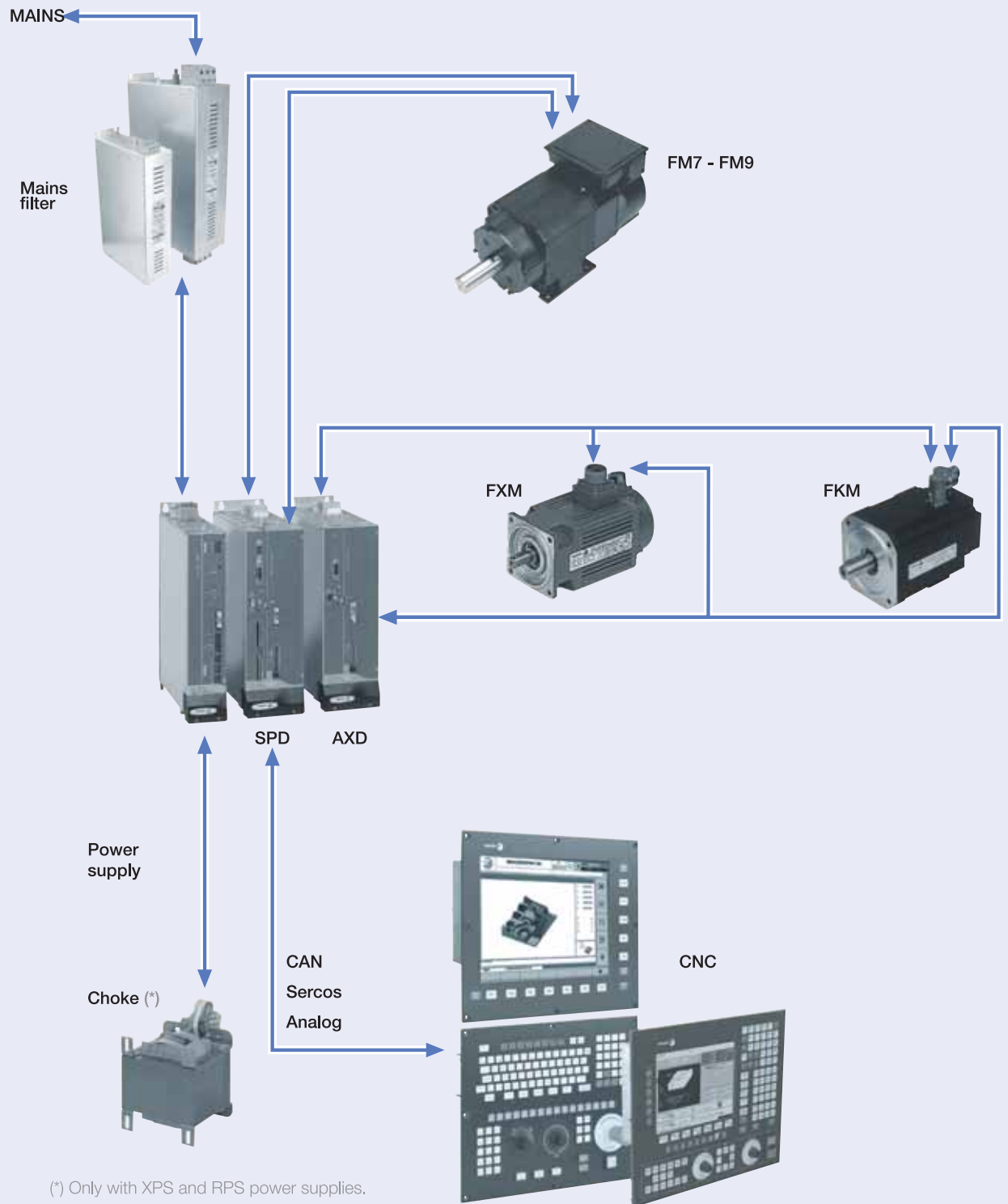

Asynchronous AC motors

For machine-tool spindles

Fagor Automation's wide range of spindle motors and drives may be used on all kinds of machine-tool spindles, providing the high reliability and best efficiency that the application may demand.

- **FM7_XXXXXX_E01 series** with single winding, for power up to 60 kW.
- **FM9_XXXXXX_E01 series** with single winding, for power greater than 60 kW.
- **FM7_XXXXXX_E03 series** with double winding, Y/Delta (star/triangle).
- **FM7_XXXXXX_HS3 series** direct drive (without pulleys), with hollow shaft for cooling the tool from the spindle and double winding (Y/Delta, star/triangle).

FM7_XXXXXX_E01 series

General characteristics

Thermal protection (meets IEC 60034-6 standard)	NTC thermistor
Degree of vibration (meets IEC 60034-14 standard)	V5 - V10 (standard) V3 - V5 (optional)
Built type (meets IEC 60034-7 standard)	Horizontal: IM B3, IM B5, IM B35 Vertical: IM V1, IM V5, IM V15
Electrical isolation of the winding (meets IEC 60034 standard)	Class F (155°C-311°F)
Degree of protection (meets IEC 60034-5 standard)	IP44
Feedback	Incremental TTL encoder of 1024 ppt (standard) 1 Vpp sinusoidal encoder of 1024 ppt (optional)

Models range

MODEL	Rated power S1 (kW)	Rated power S6, 40% (kW)	Rated torque S1 (Nm)	Rated current (Arms)	Base speed (rpm)	Maximum speed (rpm)	Inertia (kg.cm ²)	Weight (kg) Flange	Weight (kg) Foot	Modular drive	Compact drive
FM7 A037	3,7	5,5	23,5	12,4	1,500	9,000	140	47	49	SPD 1,25	SCD 1,25
FM7 A055	5,5	7,7	35	14,6	1,500	9,000	210	52	56	SPD 1,25	SCD 1,25
FM7 A075	7,5	11	47,7	19,8	1,500	9,000	260	59	64	SPD 1,35	SCD 2,35
FM7 A090	9	13	57,4	25,1	1,500	9,000	330	68	73	SPD 2,50	
FM7 A110	11	15,5	70	27,9	1,500	9,000	690	94	110	SPD 2,50	
FM7 A150	15	22	95,5	39,3	1,500	8,000	690	94	110	SPD 2,75	
FM7 A185	18,5	26	117,8	47,4	1,500	8,000	890	120	130	SPD 2,85	
FM7 A220	22	33	140	61,4	1,500	8,000	1,080	135	145	SPD 3,100	
FM7 A300	30	45	191	82,1	1,500	6,500	2,310	220	230	SPD 3,150	
FM7 A370	37	56	235	89,9	1,500	6,500	2,660	250	260	SPD 3,200	
FM7 A510	51	71	325	115,1	1,500	5,000	4,730	340	350	SPD 3,200	
FM7 B120	12	18,5	114,6	35	1,000	8,000	890	120	130	SPD 2,75	
FM7 B170	17	25	162,3	47,2	1,000	8,000	1,080	135	145	SPD 2,85	
FM7 B220	22	33	210	64,9	1,000	6,500	2,310	220	230	SPD 3,100	
FM7 B280	28	42	267,4	78,2	1,000	6,500	2,660	250	260	SPD 3,150	
FM7 C215	21,5	29	410,6	87,8	500	5,000	4,730	340	350	SPD 3,150	
FM7 C270	27	37	515,7	116,9	500	5,000	5,840	380	390	SPD 3,200	
FM7 E600	60	80	458,4	117,4	1,250	5,000	8,720	525	540	SPD 3,200	

Dimensions in mm

- FM7 xxxx-1 motors model with feet.
- FM7 xxxx-3 motors model with flange.
- FM7 xxxx-5 motors model with feet and flange.

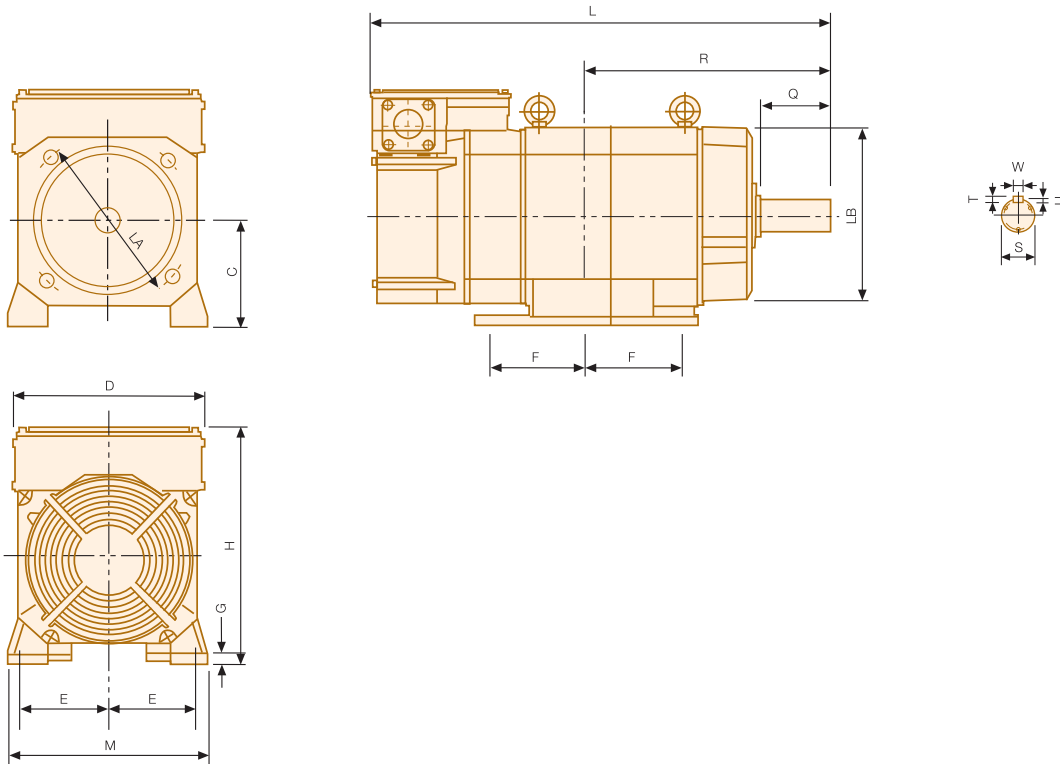

MODEL Feet	MODEL Flange	MODEL Feet and flange	C	D	E	F	G	H	L	LA	LB	M	Axis					
													R	Q	S	T	U	W
FM7 A037-3	FM7 A037-1		100	174	80	70	9	250	499	185	150 h7	188	175	60	28 h6	7 h11	4	8 h9
FM7 A055-3	FM7 A055-1		112	204	95	50	10	269	486	215	180 h7	220	200	80	32 h6	8 h11	5	10 h9
FM7 A075-3	FM7 A075-1		112	204	95	70	10	269	546	215	180 h7	220	250	110	48 h6	9 h11	5.5	14 h9
FM7 A090-3	FM7 A090-1		112	204	95	89	10	269	586	215	180 h7	220	269	110	48 h6	9 h11	5.5	14 h9
FM7 A110-3	FM7 A110-1	FM7 A110-5	160	279	127	89	16	343	571	265	230 h7	290	307	110	48 h6	9 h11	5.5	14 h9
FM7 A150-3	FM7 A150-1	FM7 A150-5	160	279	127	89	16	343	571	265	230 h7	290	307	110	48 h6	9 h11	5.5	14 h9
FM7 A185-3	FM7 A185-1	FM7 A185-5	160	279	127	105	16	343	633	265	230 h7	290	323	110	48 h6	9 h11	5.5	14 h9
FM7 A220-3	FM7 A220-1	FM7 A220-5	160	279	127	139.5	16	343	671	265	230 h7	290	375.5	110	48 h6	9 h11	5.5	14 h9
FM7 A300-3	FM7 A300-1	FM7 A300-5	180	320	139.5	127	16	407	769	350	300 h7	320	388	140	60 m6	11 h11	7	18 h9
FM7 A370-3	FM7 A370-1	FM7 A370-5	180	320	139.5	127	16	407	809	350	300 h7	320	388	140	60 m6	11 h11	7	18 h9
FM7 A510-3	FM7 A510-1	FM7 A510-5	225	388	178	155.5	21	540	842.5	400	350 h7	420	444.5	140	70 m6	12 h11	7.5	20 h9
FM7 B120-3	FM7 B120-1	FM7 B120-5	160	279	127	105	16	343	633	265	230 h7	290	323	110	48 h6	9 h11	5.5	14 h9
FM7 B170-3	FM7 B170-1	FM7 B170-5	160	279	127	139.5	16	343	671	265	230 h7	290	357.5	110	48 h6	9 h11	5.5	14 h9
FM7 B220-3	FM7 B220-1	FM7 B220-5	180	320	139.5	127	16	407	769	350	300 h7	320	388	140	60 m6	11 h11	7	18 h9
FM7 B280-3	FM7 B280-1	FM7 B280-5	180	320	139.5	127	16	407	809	350	300 h7	320	388	140	60 m6	11 h11	7	18 h9
FM7 C215-3	FM7 C215-1	FM7 C215-5	225	388	178	155.5	21	540	847	400	350 h7	420	444.5	140	70 m6	12 h11	7.5	20 h9
FM7 C270-3	FM7 C270-1	FM7 C270-5	225	388	178	174.5	21	540	897	400	350 h7	420	463.5	140	70 m6	12 h11	7.5	20 h9
FM7-E600-3	FM7-E600-1	FM7-E600-5	225	388	178	288.5	21	540	1065.5	400	350 h7	420	476.5	140	65 m6	11 h11	7	18 h9

FM9_XXXXXX_E01 series

E01 series FM9 spindle motors have forced fan cooling and single winding, with a rated power between 55 kW and 130 kW.

General characteristics

Thermal protection (meets IEC 60034-6 standard)	Thermistor KTY84-130
Degree of vibration (meets IEC 60034-14 standard)	V5
Built type (meets IEC 60034-7 standard)	Horizontal: IM B35 Vertical: IM V15
Electrical isolation of the winding (meets IEC 60034 standard)	Class F (155°C-311°F)
Degree of protection (meets IEC 60034-5 standard)	IP54
Feedback	1 Vpp sinusoidal encoder of 1024 ppt

Model range

MODEL	Rated power S1 (kW)	Rated power S6-40% (kW)	Par Nominal (Nm)	Rated current S1 (Arms)	Base speed (rpm)	Maximum speed S1 (rpm)	Inertia (kg.cm ²)	Weight (kg)
FM9-B055-C5Cx-E01	55	72	525.2	104.4	1,000	4,500	0.69	440
FM9-B071-C5Cx-E01	71	105	678	134.8	1,000	4,500	1.48	680
FM9-A100-C5Cx-E01	100	136	636.6	190	1,500	4,500	1.48	635
FM9-B113-C5Cx-E01	113	153	1,079	215	1,000	4,500	2.33	860
FM9-A130-C5Cx-E01	130	178	827.6	246.9	1,500	4,500	1.93	745

Dimensions in mm

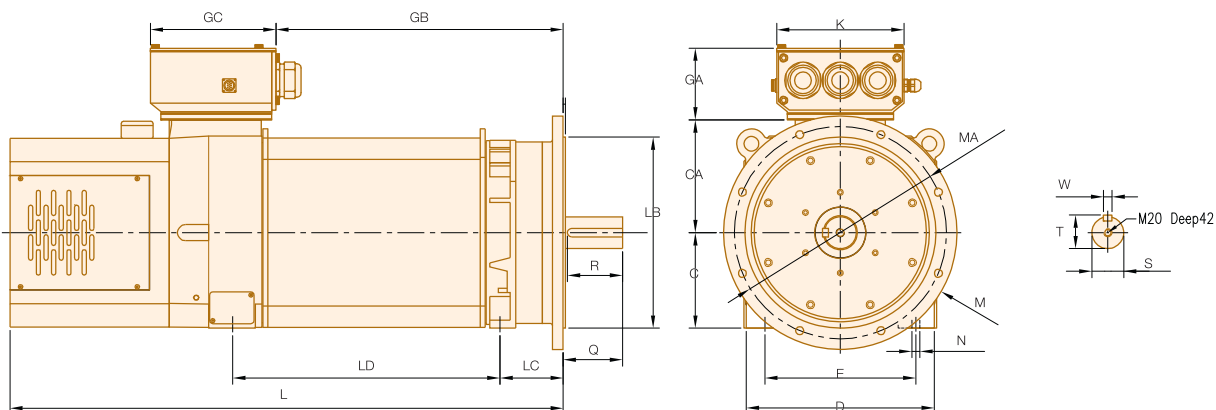

MODEL	C	CA	D	E	GA	GB	GC	K	L	LB	LC	LD	M	MA	N	Q	R	S	T	W
FM9-B055-C5Cx-E01	180	179	358	279	117	475	245	201	1078,5	300	122,5	474	---	350	19		125			
FM9-B071-C5Cx-E01						492			1119			445								
FM9-A100-C5Cx-E01	225	265,8	443	356	169	492	296	300	1119	450	149	445	550	500	18,5	140	130	75	79,5	20
FM9-B113-C5Cx-E01						677			1304			630								
FM9-A130-C5Cx-E01						587			1214			540								

FM7_XXXXXX_E03 series

E03 series FM7 spindle motors have forced fan cooling and double winding (Y/Delta, star/triangle). They can reach speeds of up to 12,000 rpm and 15,000 rpm

General characteristics

Thermal protection (meets IEC 60034-6 standard)	NTC thermistor
Degree of vibration (meets IEC 60034-14 standard)	V3 (standard)
Built type (meets IEC 60034-7 standard)	Horizontal: IM B5 Vertical: IM V1
Electrical isolation of the winding (meets IEC 60034 standard)	Class F (155°C-311°F)
Degree of protection (meets IEC 60034-5 standard)	IP44
Feedback	Incremental TTL encoder of 1024 ppt

Model range

MODEL	Rated power S1 (kW)	Rated power S6, 40% (kW)		Rated torque S1 (Nm)		Rated current (Arms)		Base speed (rpm)		Maximum speed (rpm)	Inertia (kg.cm ²)	Weight (kg)	Modular drive
		▲	▲	▲	▲	▲	▲	▲	▲				
FM7-D055-S1D0-E03	5.5	7.7	10	35	13.1	20.3	20.7	1,500	4,000	15,000	210	67	SPD 1.35
FM7-D075-S1D0-E03	7.5	11	13	47.7	17.9	26.5	25.8	1,500	4,000	15,000	260	74	SPD 2.50
FM7-D110-S1D0-E03	11	15.5	20	70	26.3	38	40	1,500	4,000	12,000	690	110	SPD 2.75
FM7-D150-S1D0-E03	15	22	26	95.5	35.8	46.4	45.7	1,500	4,000	12,000	690	110	SPD 2.85
FM7-D185-S1D0-E03	18.5	26	32	117.8	44.2	49.2	49.2	1,500	4,000	12,000	890	135	SPD 2.85
FM7-D220-S1D0-E03	22	33	40	140.1	52.5	62.3	61.7	1,500	4,000	12,000	1,080	150	SPD 3.100

Dimensions in mm

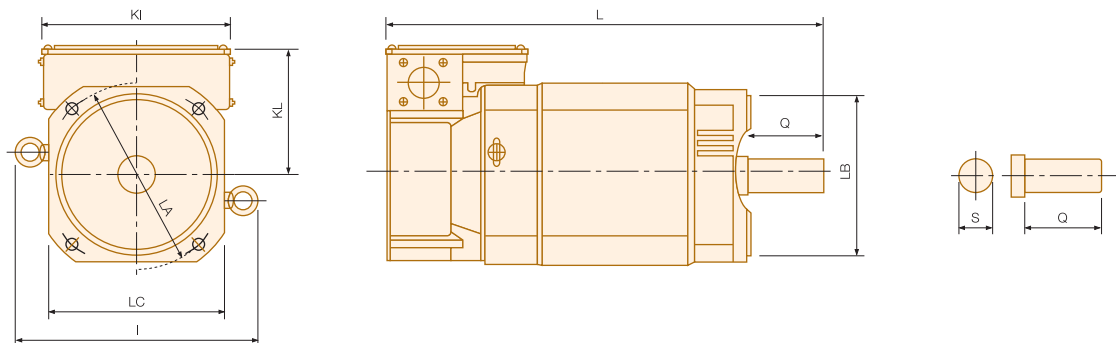

MODEL	I	KI	KL	L	LA	LB	LC	Axis	
								Q	S
FM7-D055-S1D0-E03	270	204	158	475	215	180 h7	204	60	28 h6
FM7-D075-S1D0-E03	270	250	164	506	215	180 h7	204	60	28 h6
FM7-D110-S1D0-E03	343	279	183	556	265	230 h7	250	80	38 h6
FM7-D150-S1D0-E03	343	279	183	556	265	230 h7	250	80	38 h6
FM7-D185-S1D0-E03	343	279	183	618	265	230 h7	250	80	38 h6
FM7-D220-S1D0-E03	343	279	183	665	265	230 h7	250	80	38 h6

FM7_XXXXXX_HS3 series

HS3 series FM7 spindle motors are direct-mount motors and are especially designed to be mounted on the column for direct transmission without pulleys.

They have forced fan cooling and double winding (Y/Delta, star/triangle). They can reach speeds of up to 12,000 rpm and 15,000 rpm.

The tool is secured with a coupling and they have a hole on the shaft for tool cooling.

General characteristics

Thermal protection (meets IEC 60034-6 standard)	NTC Thermistor
Degree of vibration (meets IEC 60034-14 standard)	V3 (standard)
Built type (meets IEC 60034-7 standard)	Horizontal: IM B5 Vertical: IM V1
Electrical isolation of the winding (meets IEC 60034 standard)	Class F (155°C-311°F)
Degree of protection (meets IEC 60034-5 standard)	IP44
Feedback	Incremental TTL encoder of 1024 ppt

Model range

MODEL	Rated power S1 (kW)	Rated power S6, 40% (kW)		Rated torque S1 (Nm)		Rated current (Arms)		Base speed (rpm)		Maximum speed (rpm)	Inertia (kg.cm ²)	Weight (kg)	Modular spindle drive
		▲	▲	▲	▲	▲	▲	▲	▲				
FM7-D075-S1D0-HS3	7.5	11	13	47.7	17.9	26.5	25.8	1,500	4,000	15,000	260	77	SPD 2.50
FM7-D110-S1D0-HS3	11	15.5	20	70	26.3	38	40	1,500	4,000	12,000	690	115	SPD 2.75
FM7-D185-S1D0-HS3	18.5	26	32	117.8	44.2	49.2	49.2	1,500	4,000	12,000	890	140	SPD 2.85
FM7-D220-S1D0-HS3	22	33	40	140.1	52.5	62.3	61.7	1,500	4,000	12,000	1,080	155	SPD 3.100

Dimensions in mm

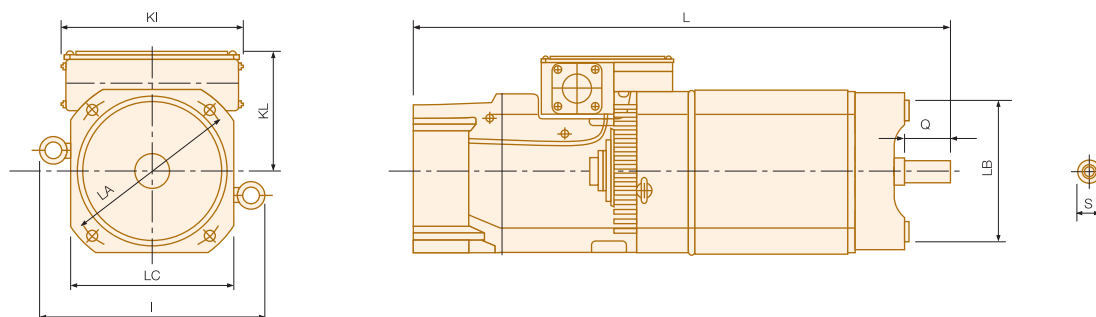

MODEL	I	KI	KL	L	LA	LB	LC	Axis	
								Q	S
FM7-D075-S1D0-HS3	271	250	158	715	215	180 h7	204	60	28 h6
FM7-D110-S1D0-HS3	343	279	183	751	265	230 h7	250	70	38 h6
FM7-D185-S1D0-HS3	343	279	183	813	265	230 h7	250	70	38 h6
FM7-D220-S1D0-HS3	343	279	183	851	265	230 h7	250	70	38 h6

Synchronous AC motors

To control axes in machine tool applications

Fagor Automation's axis servo motors are permanent-magnet synchronous motors that may be adapted to any application and meet the ever growing demands of new-generation state-of-the-art machines.

These motors are combined with AXD and ACD axis drives to make up a solid and high featured system. The type of encoder integrated for speed and position control depends on the application.

They are designed to run without external cooling because heat is dissipated off the surface of the motor. Optionally, they may carry an electromechanical brake.

FKM motors

General characteristics

Temperature sensor	Thermistor PTC KTY-84
Shaft extension	Keyless shaft (option: with key)
Mounting	Front flange
Mounting possibilities (meets IEC 34-3-72 standard)	IM B5, IM V1, IM V3
Balancing (meets DIN 45665 standard)	Halfkey balancing Class N (standard), Class R (optional)
Electrical isolation	Class F (150 °C / 302 °F)
Degree of protection	IP65 on FKM 94, 95 and 96 models IP64 (standard) / IP65 (optional) on rest of models
Fan	Not available
Brake	Optional on all models except in FKM96
Feedback	Multi-turn absolute 1 Vpp sinusoidal encoder of 1024 ppt 1 Vpp sinusoidal encoder of 1024 ppt Incremental TTL encoder of 2500 ppt (on FKM21 through FKM64 models)

Model range

MODEL	Stall torque (Nm)	Peak torque (Nm)	Rated speed (rpm)	Stall current (Arms)	Peak current (Arms)	Inertia (kg.cm ²)	Weight (kg)
FKM 21.60A	1.7	7	6,000	2.8	11	1.6	4.2
FKM 22.30A	3.2	13	3,000	2.4	10	2.9	5.3
FKM 22.50A			5,000	4	16		
FKM 22.60A			6,000	4.5	18		
FKM 42.30A	6.3	25	3,000	4.6	19	8.5	7.8
FKM 42.45A			4,500	6.9	28		
FKM 42.60A			6,000	8.5	34		
FKM 44.30A	11.6	47	3,000	8.2	33	16.7	11.7
FKM 44.40A			4,000	10.7	43		
FKM 62.30A	8.9	35	3,000	7.1	28	16	11.9
FKM 62.40A			4,000	9.3	37		
FKM 62.60A			6,000	13.1	52		
FKM 64.30A	16.5	66	3,000	12.1	48	29.5	17.1
FKM 64.40A			4,000	16.2	64		
FKM 66.20A	23.5	94	2,000	10.5	42	43	22.3
FKM 66.30A			3,000	16.4	66		
FKM 94.20A	68	204	2,000	25.4	99	430	56
FKM 95.20A	93	279	2,000	33.1	129	550	73
FKM 96.20A (*)	115	345	2,000	42.1	164	660	73

(*) Brake option not available.

Dimensions in mm

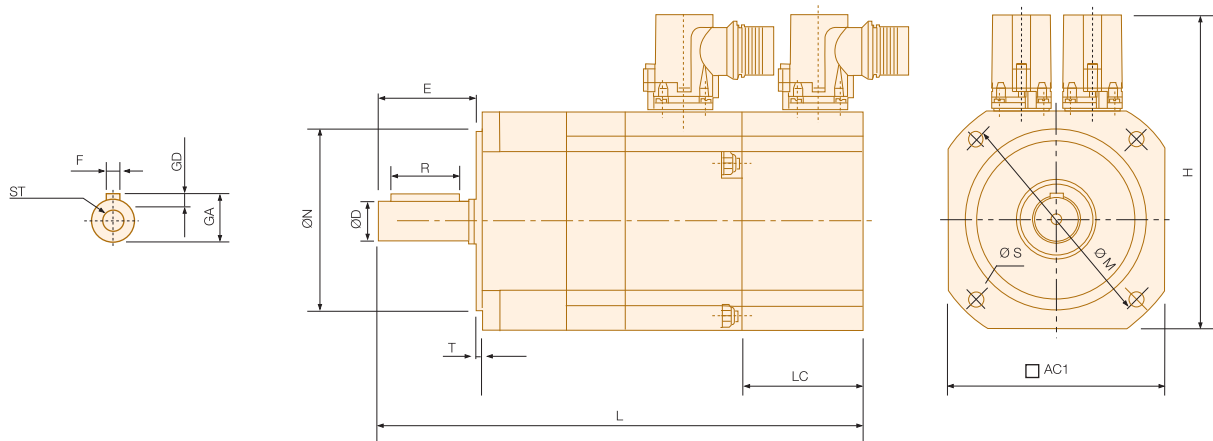

MODEL	L (without brake)	L (with brake)	E	LC	T	AC1	M	N	H	S	D	GA	GD	F	R	ST				
FKM 21	208		40	54	3	97	100	80 j6	139,5	7	19 j6	21,5	6	6	30	M6x16				
FKM 22	232																			
FKM 42	247		50	54	3.5	126	130	110 j6	168,5	9	24 j6	27	7	8	40	M8x19				
FKM 44	289																			
FKM 62	260		58	54	3.5	158	165	130 j6	200,5	12	32 k6	35	8	10	50	M10x22				
FKM 64	296																			
FKM 66	332																			
FKM 94	527	595	80	54	4	240	265	230	325,5	14,5	38 k6	41,4	8	10	63	M12x30				
FKM 95	625	693									42 k6						45,2	8	12	63
FKM 96	693	-									42 k6									

FXM motors

General characteristics

Temperature sensor	Thermistor PTC
Shaft extension	Keyless shaft (option: with key)
Mounting	Front flange
Mounting possibilities (meets IEC 34-3-72 standard)	IM B5, IM V1, IM V3
Balancing (meets DIN 45665 standard)	Full-key balancing Class N (standard), Class R (optional)
Electrical isolation	Class F (150°C / 302°F)
Degree of protection	Standard configuration: IP 64 Seal option: IP 65 Fan option: IP 54
Fan	Optional in FXM5 and FXM7 series
Brake	Optional on all models
Feedback	Multi-turn absolute 1 Vpp sinusoidal encoder of 1024 ppt 1 Vpp sinusoidal encoder of 1024 ppt Incremental TTL encoder of 2500 ppt

Model range

MODEL	Stall torque (Nm)	Peak torque (Nm)	Stall current (Arms) / Peak current (Arms)				Inertia (kg cm ²)	Weight (kg)
			1200 rpm	2000 rpm	3000 rpm	4000 rpm		
FXM 11	1.2	6		0.45/2.2	0.67/3.4	0.90/4.5	1.2	3.3
FXM 12	2.3	11		0.86/4.1	1.29/6.2	1.72/8.2	1.9	4.3
FXM 13	3.3	16		1.23/6	1.85/9	2.50/12	2.6	6.4
FXM 14	4.1	20		1.5/7.5	2.30/11.2	2.10/15.0	3.3	7.6
FXM 31	2.6	13		0.97/4.8	1.45/7.3	1.92/9.6	3.5	5.5
FXM 32	5.1	25		1.89/9.2	2.80/14.0	3.80/18.5	6	7.5
FXM 33	7.3	36		2.70/13.4	4.10/20.0	5.50/27.0	8.5	9.6
FXM 34	9.3	46		3.40/17	5.10/25	6.90/34	11	11.5
FXM 53**	11.9(17.8)*	59	2.80(4.2)*/14	4.70(7.0)*/23	7.10(10.6)*/35	9.30(14.0)*/46	22	15.8 (20)*
FXM 54**	14.8(22.2)*	74	3.50(5.3)*/17.6	5.90(8.9)*/30.0	8.70(13.1)*/44.0	11.80(17.7)*/59.0	29	17.8 (22)*
FXM 55**	17.3(25.9)*	86	4.1(6.1)*/20	6.7(10.1)*/33	10.3(15.4)*/51	14.1(21.1)*/70	36	20 (24.2)*
FXM 73**	20.8(31.2)*	104	4.9(7.4)*/25	8.2(12.3)*/41	12.3(18.5)*/62	16.5(24.7)*/82	61	29 (33.2)*
FXM 74**	27.3(40.9)*	135	6.6(9.8)*/32	11.1(16.5)*/55	16.2(24.3)*/80	22.1(33.1)*/109	79	31.6 (35.8)*
FXM 75**	33.6(50.4)*	165	8(12.0)*/39	13.3(20.0)*/65	19.9(29.9)*/98	26.6(39.9)*/131	97	36 (40.2)*
FXM 76**	39.7(59.5)*	195	9.4(14.1)*/46	15.7(23.5)*/77	23.6(35.3)*/116	32.1(48.2)*/158	115	40 (44.2)*
FXM 77**	45.6(68.4)*	225	11.0(16.6)*/55	17.8(26.8)*/88	29.0(43.5)*/143	36.6(55.0)*/181	133	43 (47.2)*
FXM 78**	51.1(76.6)*	255	12.6(19.0)*/63	20.7(31.0)*/103	28.4(42.6)*/142	42.7(63.9)*/213	151	47 (51.2)*

(*) Values of electro-ventilated motors in parenthesis.

(**) For motor sizes 5 and 7, there is the option of electro-ventilated motor that permits obtaining about 50 % more torque.

Dimensions in mm

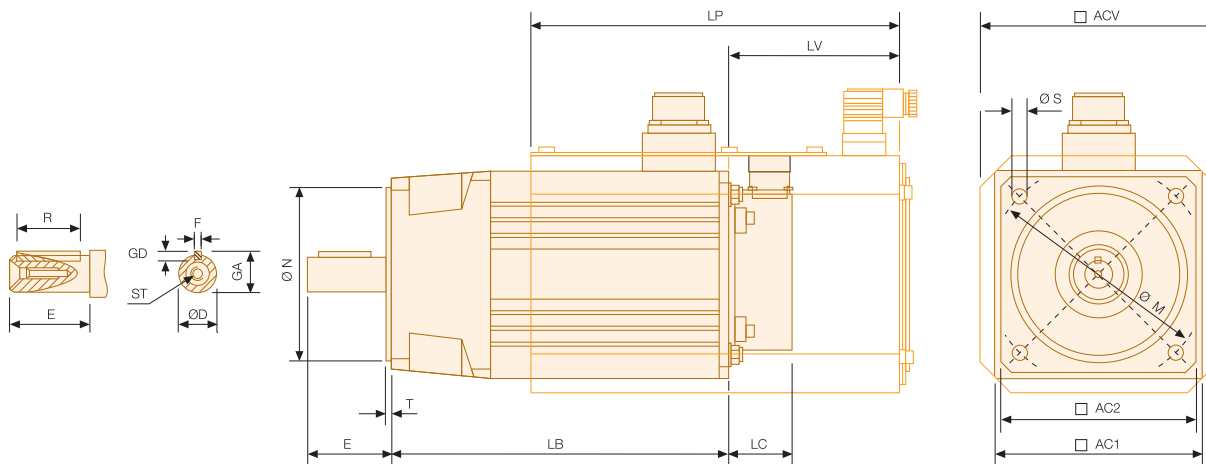

MODEL	E	LB	BR (1)	T	AC1	AC2	M	N	S	D	GA	GD	F	R	ST	LP (2)	LV (2)	ACV (2)
FXM 11	30	136	25	3	86	86	100	80 J6	7	14 J6	16	5	5	20	M5X12.5			
FXM 12		171																
FXM 13		206																
FXM 14		241																
FXM 31	40	152	23	3	114	105	115	95 J6	10	19 J6	21.5	6	6	30	M6X16			
FXM 32		187																
FXM 33		222																
FXM 34		257																
FXM 53	50	237	28	3.5	145	145	165	130 J6	12	24 J6	27	7	8	40	M8X19	259	128	165
FXM 54		272																
FXM 55		307																
FXM 73	58	256	41	4	185	185	215	180 J6	15	32 K6	35	8	10	50	M10X22	303	128	205
FXM 74		291																
FXM 75		326																
FXM 76		361																
FXM 77		396																
FXM 78		431																

	LC
Resolver	33.5
Encoder	46

(1) Add BR to the LB dimensions, for motors with brake.

(2) Only on electro-ventilated models.



FAGOR AUTOMATION

Fagor Automation, S. Coop.

Bº San Andrés, 19
 E-20500 Arrasate - Mondragón
 SPAIN
 Tel. : +34 943 719 200
 Fax. : +34 943 791 712
 E-mail : info@fagorautomation.es



Fagor Automation holds the ISO 9001
 Quality System Certificate and the
 CE Certificate for all products manufactured.

www.fagorautomation.com

FAGOR AUTOMATION shall not be held responsible for any printing or transcribing errors in this catalog and reserves the right to make any changes to the characteristics of its products without prior notice.

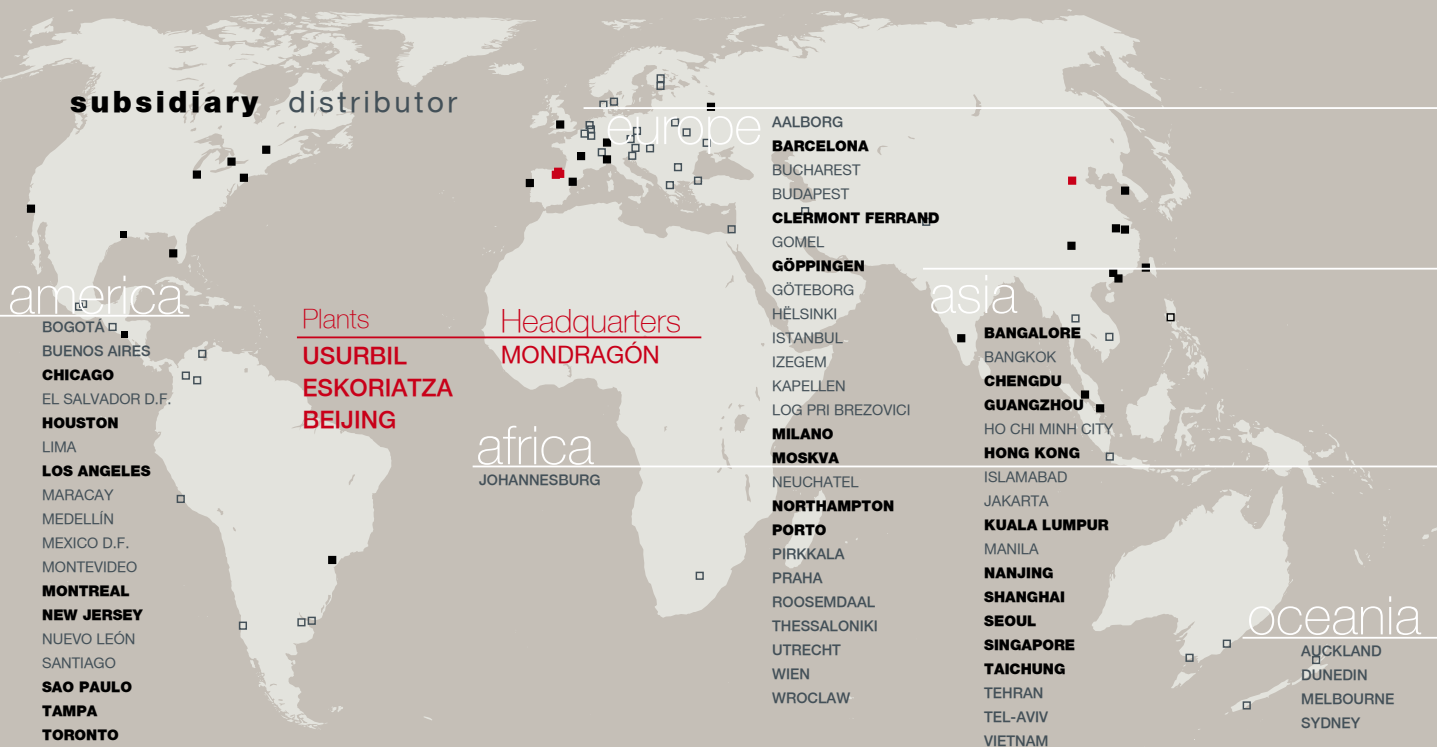

worldwide automation