

MOTOR

FM7/FM9

Installation manual

Ref.1107



FAGOR AUTOMATION

Title	MOTOR FM7/FM9.
Type of documentation	Description and installation of FM7 and FM9 asynchronous spindle motors. Parameter setting at the drives.
Electronic document	man_fm7_fm9_motors.pdf
Language	English
Manual reference	Ref.1107
Headquarters	Fagor Automation, S. Coop. Bº San Andrés 19, apdo. 144 CP. 20500 - Arrasate - Mondragón Gipuzkoa (Spain) www.fagorautomation.com info@fagorautomation.es
Customer support	 +34 943 719200
Service Department	 +34 943 771118

Version history.

Manual reference	Events
0209	FM7 family. E01 series
0306	FM7 family. E02 series
0604	FM7 family. E03 series
0702	FM7 family. HS3 series
0712	FM7 family. FM7-E600-□□□□-E01 model
1107	FM9 family. E01 series, models: FM9-B055-C5C□-E01, FM9-B071-C5C□-E01, FM9-A100-C5C□-E01, FM9-B113-C5C□-E01, FM9-A130-C5C□-E01

All rights reserved. No part of this documentation may be copied, transmitted, transcribed, stored in a backup device or translated into another language without Fagor Automation's permission.



Responsibility exemption

The information described in this manual may be subject to changes due to technical modifications. Fagor Automation S. Coop. reserves the right to change the contents of this manual without prior notice.

The content of this manual and its validity for the product described here has been verified. Nevertheless, the information, technical or otherwise, in these manuals or in any other type of documentation is not guaranteed to be integral, sufficient or up to date.

Involuntary errors are possible, hence the absolute match is guaranteed. However, the contents of manuals and documents are regularly checked and updated implementing the pertinent corrections in later editions.

Fagor Automation S. Coop. will not be held responsible for any losses or damage, direct, indirect or by chance that could result from that information and it will be the user's responsibility to use it.

Responsibility and warranty claims are excluded in case of shipping damage, wrong usage of the unit in wrong environments or when not used for the purpose for which it has been designed, ignoring the warnings and safety indications given in this document and/or legal ones that may be applied to the work place, software modifications and/or repairs made by unauthorized personnel, damage caused by the influence of other nearby equipment.

Warranty

The warranty terms may be requested from your Fagor Automation representative or through the usual commercial channels.

Registered trademarks

All registered trade marks, even those not indicated are also acknowledged. When some are not indicated, it does not mean that they are free.

GENERAL INDEX

1. DESCRIPTION	17
Features and design	17
Outside appearance.....	20
Terminal box. Layout and identification	21
General characteristics	23
Temperature sensors.....	25
Simple NTC thermistor.....	25
KTY84-130 thermistor	26
Feedback devices	27
Magnetic TTL encoder.....	27
C axis SinCos encoder.....	27
2. ELECTRICAL CHARACTERISTICS	29
Definitions.....	29
Operating modes.....	31
Operating zones.....	31
Influence of supply voltage.....	32
Y-D winding connection switching.....	33
Y winding and D winding.....	33
Comparison charts F/f and M/f depending on Y-D connection	35
Technical data. Power/torque-speed graphs.....	36
FM7-XXXX-XXXX-E01/E02 series.....	37
FM9-XXXX-C5CX-E01 series	55
FM7-DXXX-S1D0-E03 series.....	60
FM7-DXXX-S1D0-HS3 series	66
3. MECHANICAL CHARACTERISTICS	71
Built	71
Level of vibration	73
Balancing.....	75
Bearings	76
Radial loads	77
"Radial load - turning speed" diagrams.....	78
Couplings.....	80
Direct coupling	80
Belt coupling.....	80
Gear coupling.....	81
Mounting a pulley or gears.....	81
Dimensions.....	82
FM7-XXXX-X3XX-E01/E02 series	82
Assembling precision	84
FM7-XXXX-X1XX-E01/E02 series	84
Assembling precision	86
FM7-XXXX-X5XX-E01/E02 series	87
Assembling precision	89
FM9-XXXX-C5CX-E01 series	90
Assembling precision	90
FM7-DXXX-S1D0-E03 series.....	91
Assembling precision	91
FM7-DXXX-S1D0-HS3 series	92
Assembling precision	93



FM7/FM9

Ref.1107



4. INSTALLATION	95
Overview	95
Motor installation	95
Fan installation	96
Brake	96
Connections	97
Power. Motor-drive	97
Feedback. Motor-drive	105
Fan	118
5. MAINTENANCE	123
Overview	123
Daily inspections	123
Periodic inspections	124
Element replacement periods	124
Bearings	124
Fan	125
Fan replacement	125
Spare parts	128
FM7. E01 and E02 series	128
FM7. E03 series	129
FM7. HS3 series	129
FM9. E01series	129
6. SELECTION	131
Spindle motor selection	131
Power demanded from a motor for a particular load	131
Power required by the load	132
Power needed to accelerate or decelerate the spindle motor	135
Technical characteristics	138
FM7-XXXX-XXXX-E01/E02 series	138
FM9-XXXX-C5CX-E01 series	139
FM7-DXXX-S1D0-E03 series	139
FM7-DXXX-S1D0-HS3 series	140
Spindle drive selection	141
Characteristics plate	143
Sales reference	145



FM7/FM9

Ref.1107

ABOUT THE MANUAL

Title	MOTOR FM7/FM9. INSTALLATION MANUAL
Type of documentation	Description and installation of FM7 and FM9 asynchronous spindle motors. Association with modular and compact drives.
Internal code	It belongs to the manual directed to the manufacturer (OEM). The manual code does not depend on the software version. MAN MOTOR FM7/FM9 (IN) Code 04754031
Manual reference	Ref.1107

Startup



Verify that the machine that integrates this motor meets the 2006/42/EC Directive on machine safety.
Before starting the motor up, read the indications of this chapter.

Warning



The information described in this manual may be subject to changes due to technical modifications.
FAGOR AUTOMATION, S. Coop. reserves the right to change the contents of this manual without prior notice.

Headquarters

Fagor Automation, S. Coop.
Bº San Andrés 19, Apdo.144
CP-20500 Arrasate-Mondragón
www.fagorautomation.com
info@fagorautomation.es



+34 943 719200



+34 943 771118 (Technical Support)

The contents of this manual have been verified and matched with the product described here. Even so, it may contain involuntary errors that make it impossible to ensure an absolute match. However, the contents of this document are regularly checked and updated implementing the pertinent corrections in a later edition.

All rights reserved. No part of this documentation may be copied, transmitted, transcribed, stored in a backup device or translated into another language without Fagor Automation's permission.

FAGOR 

FM7/FM9

Ref.1107

DECLARATION OF CONFORMITY

Manufacturer Fagor Automation S.Coop.
Bº San Andrés 19; C.P. 20500, Mondragón, Gipuzkoa - Spain.

We hereby declare, under our responsibility that the product:

FAGOR DDS SERVO DRIVE SYSTEM

consisting of the following modules and accessories:

PS-25B4, PS-65A, APS-24
XPS-25 , XPS-65
RPS-80, RPS-75 , RPS-45, RPS-20
AXD/SPD/MMC 1.08, 1.15, 1.25, 1.35
AXD/SPD/MMC 2.50, 2.75, 2.85
AXD/SPD/MMC 3.100, 3.150, 3.200, 3.250
ACD/SCD/CMC 1.08, 1.15, 1.25
ACD/SCD/CMC 2.35, 2.50
RM-15, ER, ER+TH, ER+TH-x/x+FAN, CM 1.60, CHOKE
MAINS FILTER 42A, MAINS FILTER 130A, MAINS FILTER 180A
FXM, FKM, FM7, FM9

Note. Some additional characters may follow the models indicated above. They all comply with the directives listed here. However, compliance may be verified on the label of the unit itself.

mentioned on this declaration, meet the requirements on:

Safety

EN 60204 -1: Machinery safety. Electrical equipment of the machines.
2006 Part 1: General requirements.

Electromagnetic compatibility

EN 61800 -3: EMC directive on servo drive systems.
2004

In compliance with EC directives 2006/95/EC on low voltage and 2004/108/CE on Electrical Compatibility.

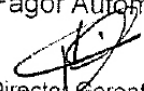

Fagor Automation, S. Coop.

Director Gerente
Pedro Ruiz de Aguirre

In Mondragón July 1st 2009

FM7/FM9

Ref.1107

WARRANTY TERMS

Initial warranty

All products manufactured or marketed by FAGOR carry a 12-month warranty for the end user.

In order to prevent the possibility of having the time period from the time a product leaves our warehouse until the end user actually receives it run against this 12-month warranty, the OEM or distributor must communicate to FAGOR the destination, identification and installation date of the machine by filling out the Warranty Form that comes with each product.

The starting date of the warranty for the user will be the one appearing as the installation date of the machine on the Warranty Form.

This system ensures the 12-month warranty period for the user.

FAGOR offers a 12-month period for the OEM or distributor for selling and installing the product. This means that the warranty starting date may be up to one year after the product has left our warehouse so long as the warranty control sheet has been sent back to us. This translates into the extension of warranty period to two years since the product left our warehouse. If this sheet has not been sent to us, the warranty period ends 15 months from when the product left our warehouse.

FAGOR is committed to repairing or replacing its products from the time when the first such product was launched up to 8 years after such product has disappeared from the product catalog.

It is entirely up to FAGOR to determine whether a repair is to be considered under warranty.

Exclusive clauses

The repair will take place at our facilities. Therefore, all shipping expenses as well as travelling expenses incurred by technical personnel are NOT under warranty even when the unit is under warranty.

The warranty will be applied so long as the equipment has been installed according to the instructions, it has not been mistreated or damaged by accident or negligence and has been handled by personnel authorized by FAGOR.

If once the service call or repair has been completed, the cause of the failure is not to be blamed on the FAGOR product, the customer must cover all generated expenses according to current fees.

No other implicit or explicit warranty is covered and FAGOR AUTOMATION shall not be held responsible, under any circumstances, of the damage which could be originated.

Service contracts

Service and Maintenance Contracts are available for the customer within the warranty period as well as outside of it.



FM7/FM9

Ref.1107

To ensure a long life for the AC spindle motor, read carefully the procedures indicated in the CONTENTS section.

This manual contains detailed documentation of FM7 / FM9 series motors as well as their associated AC spindle drives.

GENERAL PRECAUTIONS

This manual may be modified due to improvements to the product, modifications or changes in their specifications.

For a copy of this manual, if its issue has been lost or damaged, contact your FAGOR dealer.

FAGOR shall not be held responsible for any modification made to the product by the user. This means the cancellation of the warranty.

CONTENTS

1.	Operation safety	9
2.	Usage	10
3.	Storage	11
4.	Shipping	12
5.	Installation.....	13
6.	Cabling	14
7.	Operation.....	15
8.	Maintenance and inspection.....	16



FM7/FM9

Ref.1107

1. Operation safety

Symbols that may appear in this manual

Carefully read the following instructions before using the motor. In these instructions, the operating safety conditions are identified by the following labels.



Danger or prohibition symbol.

It indicates the actions or operations that could harm people or units.



Warning or caution symbol.

It indicates situations that could be caused by certain operations and the actions to take to prevent them.



Mandatory symbol.

It indicates actions or operations that **MUST** be carried out.



Information symbol.

It indicates notes, warnings and advises.

Symbols that the product may carry



Ground protection symbol.

It indicates that that point must be under voltage.

After reading these instructions, have them always handy for those using the equipment.

CONTENTS
Operation safety

0.

2. Usage



Observe the following sections to avoid electrical discharges or any harm.

Take to ground the ground terminals of the motor and of the drive as specified by your international and/or local electrical regulation. Ignoring this warning may cause electrical discharges.

Use a ground connection according to the standard local and/or international regulation.

Do not damage the cables or apply excessive force on them. Do not load heavy items on them or crimp them with bolts or stapes. Ignoring this warning may cause electrical discharges.



Consider only the motor-drive combinations specified in the manual. Ignoring this warning may cause poor performance or not to work at all.

Use the shortest cables possible in the electrical installations. Separate the power cables from the signal cables. The noise on the signal cables may cause vibrations or poor performance of the unit.

Never install them in places exposed to water splashes, gasses and flammable or corrosive liquids or near flammable substances. Ignoring this warning may cause fire or poor performance.

Use it under the following ambient and work conditions:

- Interiors without corrosive or explosive gasses.
- Ventilated places without dust or metal particles.
- Ambient temperature between 0°C (40°C) and 32°F (104°F) non freezing.
- Relative humidity between 20% and 80% (non condensing).
- Altitude 1000 meters above sea level.
- Locations that may be cleaned, maintained and tested.

When using it in places with too much water or oil splashes, it must be covered with a guard or other protection items.

0.

CONTENTS
Usage

3. Storage



Do not store the unit in places exposed to water splashes or corrosive liquids or gasses.



Store the motor horizontally and protected against any possible blow. Make sure that no strange elements get in through the openings of the cooling system.

Store the equipment avoiding direct exposure to the sun, keeping temperature and humidity within the specified ranges (temperature between 0°C (32°F) and 60°C (140°F) and relative humidity between 5% and 95%)

0.
Storage
CONTENTS



FM7/FM9

Ref.1107

4. Shipping



Do not pull the cables or lift the motor up from its shaft in transit. Ignoring this warning may cause personal injury or poor motor performance due to damage to the motor.

Do not load the products too much. Ignoring this warning may cause the load to break or personal injury.



Use only the eyebolts of the motor to lift it up and transport it. Do not try to move it when it is connected to other equipment.

Before lifting it or moving it, make sure that they eyebolts are properly bolted in, the load is balanced and the cable and the sling used to move the motor is the right one.

0.

CONTENTS
Shipping



FM7/FM9

Ref.1107

5. Installation



Do not climb on top of the motor nor load it with heavy objects. Ignoring this warning may cause personal injury.

Do not block either the air intake or the air output in ventilated motors and prevent strange materials from getting in. Ignoring this warning may cause fire or damage to the unit.

When unpacking, use the proper tool to open the box. Ignoring this warning may cause personal injury.

Cover the rotary parts so they cannot be touched. Ignoring this warning may cause personal injury.

The motor shaft extension is covered with anti-corrosive paint. Before installing the motor, remove the paint with a cloth dampened in liquid detergent.



When connecting the motor to the machine load, special care must be taken with centering, the tension of the pulley and the parallelism of the pulley.

A flexible coupling must be used to couple the motor with the machine load.

The encoder attached to the motor shaft is a precision element. Do not apply excessive force on to the drive shaft. The machine must be designed so the axial and radial loads applied to the shaft extension while in operation must be within the range indicated in this manual for this model.

No additional machining must be carried out to the motor.

Flange-mount models may be installed with the load placed horizontally or vertically at the drive shaft with the motor shaft extension facing down (only on FM7 series). On FM9 series, the shaft extension may be facing up or down.

If the motor shaft is horizontal, the terminal box must be facing up (on applicable models).

Foot-mount models must be installed on the floor with the foot down or vertically with the shaft extension facing down (only on FM7 models). On FM9 series, the shaft extension may be facing up or down.

For further details, refer to this manual for the possible builds for each model.

0.**CONTENTS**
Installation**FAGOR** **FM7/FM9****Ref.1107**

6. Cabling



The installation must comply with directive EMC 2004/108/CE.

The motor is component to be incorporated on machines. They must comply with Machine Safety Directive 2006/42/CE and cannot be started up until this directive is met.

Install the cables safely according to the connection diagrams. Ignoring this warning may cause the motor to run away and personal injury.

Make sure that the power input is off before doing the installation.

Foresee a protection circuit so the main machine is not connected when the motor-fan group is not running (when applicable).

Carry out the right ground connection and electrical noise control (disturbances).

Use the shortest cables possible in the installation. Run the power cables as far away from the signal cables as possible. Do not run the power cables and the signal cables through same cable hose or conduit. The noise in signal cables may cause vibration or poor performance.

Use the cables specified by FAGOR. When using other cables, check the rated current of the unit and bear in mind the work environment in order to properly select the cables.

0.

CONTENTS
Cabling



FM7/FM9

Ref.1107

7. Operation



Do not run the unit with the lid of the terminal box open. After cabling (when applicable), do not forget to close it. Ignoring this danger warning may cause electrical discharges.



To properly check the motor, it must be properly secured and disconnected from the machine load. Then, run the pertinent checks and connect the machine load again. Ignoring this warning may cause personal injury.

In case of error or alarm, correct its cause. First verify the safety conditions and then resume the operation after eliminating the error. See the "dds-software" manual of the drive.

If there is a momentary power loss, disconnect the power supply. The machine may run suddenly causing personal injury.



Use only the eyebolts of the motor to lift it up or move it. Do not attempt to move the motor while it is attached to another unit without freeing it first.

0.**CONTENTS**
Operation**FAGOR** **FM7/FM9****Ref.1107**

8. Maintenance and inspection



Only authorized personnel may take the unit apart and repair the unit.

Contact your FAGOR representative before taking the motor apart.

See the instruction of the following table to carry out the inspection and daily maintenance of the motor. The AC spindle motor only needs a simple daily inspection. The inspection periods indicated in the table are only a guideline. Adjust the inspection periods depending on the operating conditions and work environment.

Inspection items	Frequency	Operation	Remarks
Vibration & noise	Daily	Touch & listen	Vibration and noise must not exceed normal values.
Outside	According to requirements	Clean with a dry cloth or compressed air.	
Insulation resistance	Annual	Disconnect the motor from the drive and verify that the resistance is > 10 MΩ measured with 500 V tester.	If the resistance is < 10 MΩ, contact FAGOR. Do not measure the isolation resistance or test the limit voltage at the encoder.
Overall	Every 12000 hours or 5 years (whichever comes first)	Contact your FAGOR agent.	Do not try to solve failures or do any cleaning by third parties.

Note. Measure the isolation resistance between each phase U, V and W of the power cables and the armature ground (FG).

0.

CONTENTS
Maintenance and inspection



FM7/FM9

Ref.1107

DESCRIPTION



1.1 Features and design

Fagor FM7 and FM9 series motors are asynchronous, also called induction motors, with a two-pole-pair (4 pole) squirrel cage rotor and are especially designed to work on machine tool spindles.

These motor families group different series. Thus, the FM7 family has the (E01, E02 and E03) series depending on the maximum speed they can reach. There is also a fourth series (HS3) with a hollow shaft for cooling the tool from the spindle.

The FM9 family only has the E01 series.

Its features are:

Wide range of rated power

Its highly robust design, the use of high precision bearings (special bearings) and other elements used in their design make it possible to use this motor in the following ranges of power.

Hence, we refer to the:

FM7-□□□□-□□□□-E01 series

T. 1/1 Range of rated power in S1 for the maximum speed of the FM7-□□□□-□□□□-E01 series.

Max. speed (rpm)	Range of rated power in S1 duty cycle
9000	3.7 to 11
8000	12 to 22
6500	22 to 37 (except that of 21.5)
5000	21.5, 27, 51 and 60

FM9-□□□□-C5C□-E01 series

T. 1/2 Range of rated power in S1 for the maximum speed of the FM9-□□□□-C5C□-E01 series.

Max. speed (rpm)	Range of rated power in S1 duty cycle
5000	55
4500	71, 100, 113, 130

FM7-□□□□-□□□□-E02 series

T. 1/3 Range of rated power in S1 for the maximum speed of the FM7-□□□□-□□□□-E02 series.

Max. speed (rpm)	Range of rated power in S1 duty cycle
12000	3,7
10000	5.5 to 11
9000	12 to 22 (except that of 21.5)
6500	22
6000	21.5, 27 and 51



FM7/FM9

Ref.1107

1.

DESCRIPTION
Features and design

FM7-□□□□-□□□□-E03 series

T. 1/4 Range of rated power in S1 for the maximum speed of the FM7-□□□□-□□□□-E03 series.

Max. speed (rpm)	Range of rated power in S1 duty cycle
15000	5.5 to 7,5
12000	11 to 22

FM7-□□□□-□□□□-HS3 series

T. 1/5 Range of rated power in S1 for the maximum speed of the FM7-□□□□-□□□□-HS3 series.

Max. speed (rpm)	Range of rated power in S1 duty cycle
15000	7,5
12000	11 to 22

The mounting methods are:

T. 1/6 Mounting methods.

Series	Mounting type
FM7-□□□□-□□□□-E01	Foot, flange, foot + flange
FM9-□□□□-C5C□-E01	Foot + flange
FM7-□□□□-□□□□-E02	Foot, flange, foot + flange
FM7-□□□□-□□□□-E03	Flange
FM7-□□□□-□□□□-HS3	Flange

Low vibration

A low level of vibration is achieved by reducing the size of the motor and adjusting the balancing for high speed.

High reliability

For the FM7 family, the motor protection level meets the IP 44 standard and may have a standard magnetic TTL encoder in all the series (except in the E600) or a C axis 1024 ppt SinCos™ Stegmann™ sinusoidal encoder that is optional in E01 series (except in the E600 that is optional) and E02 series that are very reliable for velocity and position feedback. The E03 and HS3 series do not have the "C axis encoder" feedback as an option.

For the FM9 family, the motor protection level meets IP 54 and offers a C axis 1024 ppt SinCos™ Stegmann™ sinusoidal encoder.

Cooling

For the FM7 family, all series have a fan connected to three-phase 400 V AC (50/60Hz) as independent cooling system. The cooling air goes in through the machine load end and goes out through its opposite end, hence avoiding orienting the machine in the direction of the air output.

All models of the HS3 series have air cooling and are especially designed to be mounted directly on the spindle. It has a hollow shaft that allows the cooling air flow to the tool that has internal cooling directly from the spindle itself.

For the FM9 family, all the models of the E01 series come with a three-phase fan that may be connected to 230/400 V AC (Δ/Y) - 50 Hz or to 460 VAC (Y) - 60 Hz as an independent cooling system. The cooling air goes in through the machine load end and goes out through its opposite end, hence avoiding orienting the machine in the direction of the air output.



FM7/FM9

Ref.1107

Star delta winding connection

For the la familia FM7, the E03 and HS3 series have a winding with 6 different terminals for star (Y) or delta (triangle) connection. It is also possible to toggle from one to the other without stopping the motor using a maneuver with two external magnetic contactors located between the motor and the drive make it possible to select material removing conditions at low speed and high torque (star winding connection) or fine machining at high speed and low torque (delta winding connection).

For the FM9 family, although the E01 series also has 6-terminal winding, only consider the star (Y) connection as the motors leave the factory.

1.

DESCRIPTION
Features and design

FAGOR 

FM7/FM9

Ref.1107

1.2 Outside appearance

The following figure shows the external appearance of Fagor FM7/FM9 asynchronous spindle motors and the location of the terminal box that has the connectors for connecting power, the motor feedback and the fan (only on FM7 models). FM9 models have a second terminal box for connecting the fan.

1.
DESCRIPTION
Outside appearance

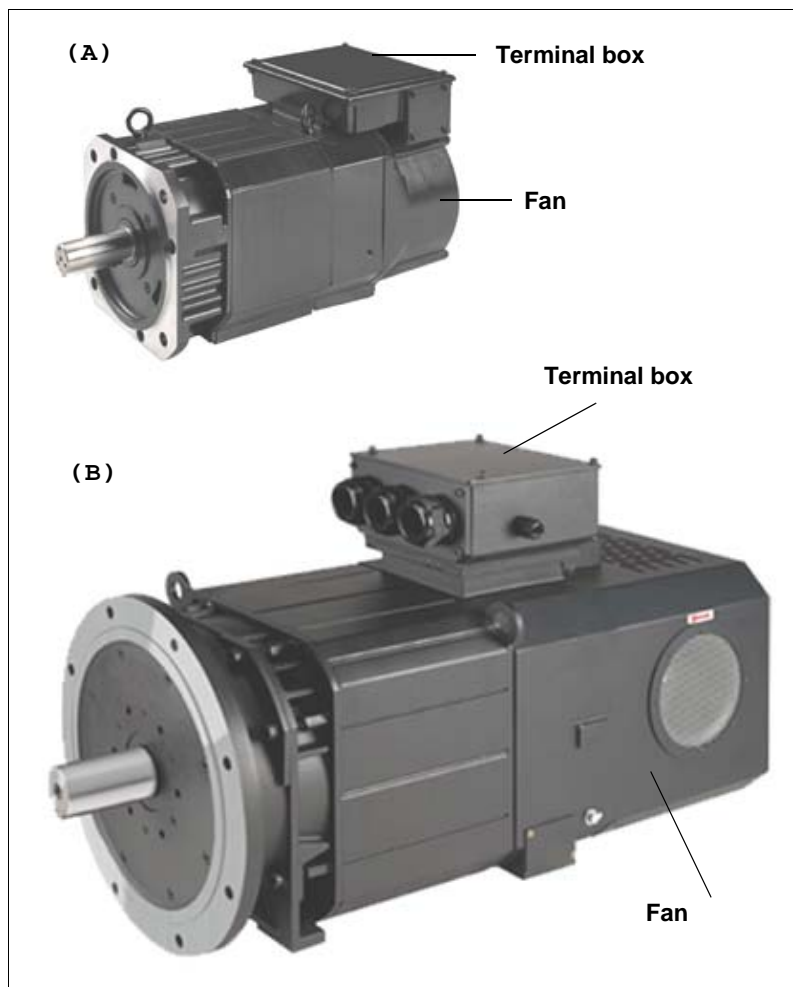

F. 1/1

Asynchronous spindle motors. A. FM7 family. B. FM9 family.

1.3 Terminal box. Layout and identification

Connection identification on FM7 models

The layout of the terminals in the box on top of the motor depends on the type of motor. **F. 1/2** the upper image shows the terminal box for the FM7-□□□□-□□□□-E01 and FM7-□□□□-□□□□-E02 series. **F. 1/2** the lower image shows the terminal box for the FM7-□□□□-□□□□-E03 and FM7-□□□□-□□□□-HS3 series.

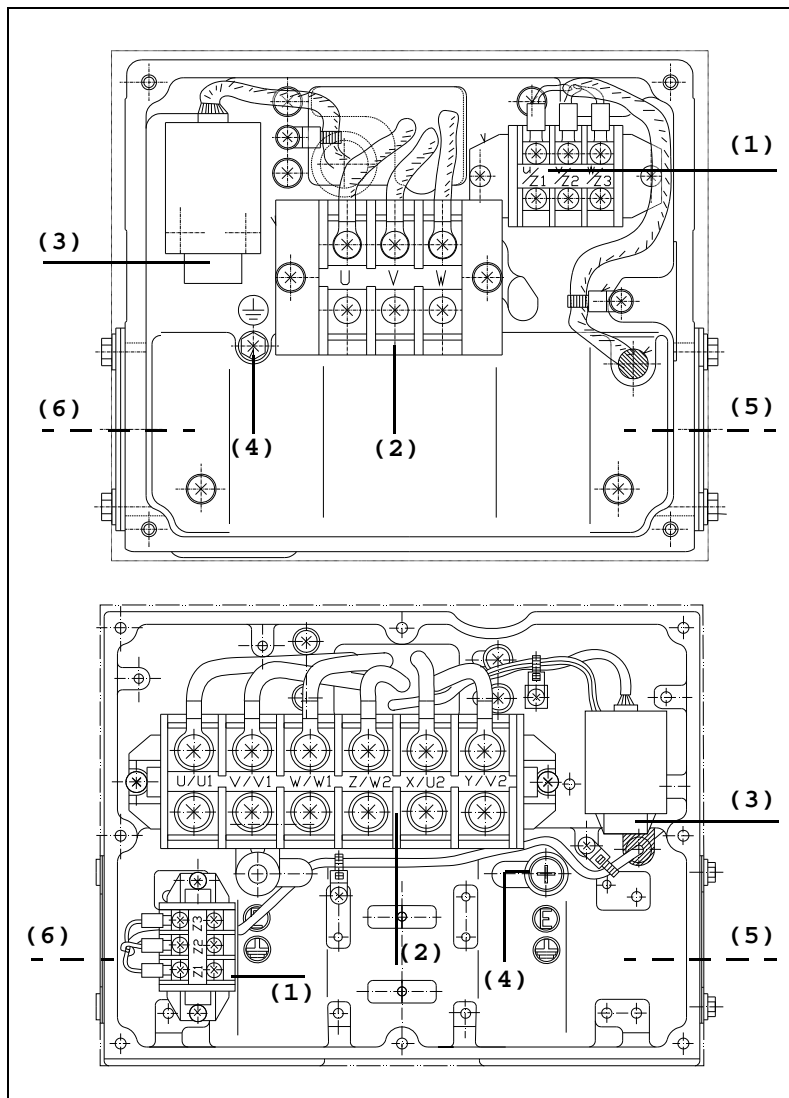

F. 1/2

Layout of the terminals and connectors inside the terminal box.

T. 1/7 Terminal box.

Nr	Name
1	3 terminals for connecting the fan
2	6 terminals for connecting the motor
3	Feedback (encoder) connecting connector
4	Ground bolt
5	Cable input
6	Cable input

Note that it is possible to find other layouts of the connection terminals very similar to the ones on the figure. They are so similar that the user will have no trouble identifying them.

1.

DESCRIPTION
Terminal box. Layout and identification



FM7/FM9

Ref.1107

1.

DESCRIPTION

Terminal box. Layout and identification

Connection identification on FM9 models

The layout of the terminals in the box on top of the motor depends on the type of motor. **F. 1/3** the upper image shows the terminal box for the FM9-B055-C5C□-E01 series. **F. 1/3** the lower image shows the terminal box for the FM9-B071-C5C□-E01, FM9-A100-C5C□-E01, FM9-B113-C5C□-E01 and FM9-A130-C5C□-E01 series.

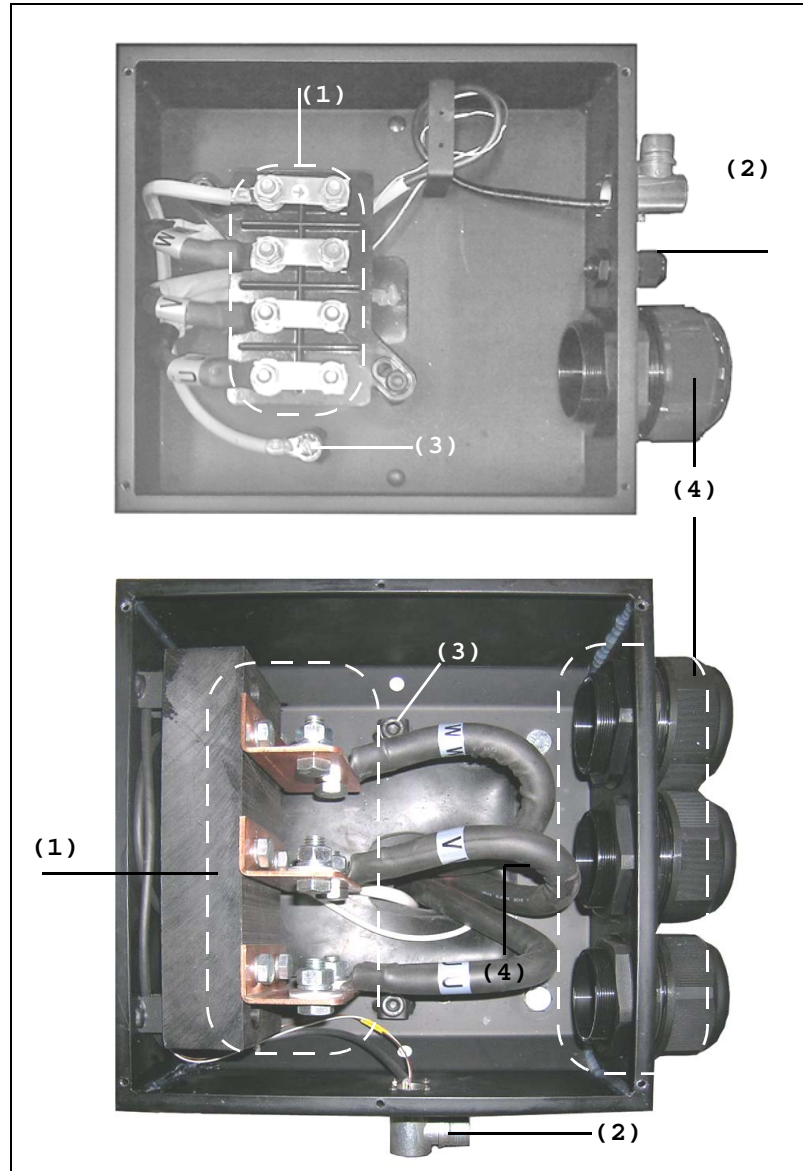

F. 1/3

Layout of the terminals and connectors inside the terminal box depending on motor model.

T. 1/8 Terminal box.

Nr	Name
1	Terminals/plates for motor power connection
2	Connector for encoder connection
3	Ground bolt
4	Cable gland(s) of the power cable hose

Observe that the fan connecting terminals are in another smaller terminal box attached to the fan.



FM7/FM9

Ref.1107

1.4 General characteristics

General technical data of FM7 models

T. 1/9 General technical data. FM7, E01 and E02 series.

FM7-□□□□-□□□□-E01 / FM7-□□□□-□□□□-E02	
Motor type	Induction. Squirrel cage
Thermal protection (meets IEC 60034-6 standard)	NCT thermistor
Level of vibration (meets IEC 60034-14 standard)	V5 - V10 (standard) V3 - V5 (optional)
Type of construction (meets IEC 60034-7 standard)	Horizontal: IM B3, IM B5, IM B35 Vertical: IM V1, IM V5, IM V15
Electrical insulation of the winding (meets IEC 60034 standard)	Class F (155 °C / 311 °F)
Degree of protection (meets IEC 60034-5 standard)	IP 44
Storage temperature	From 0 °C to 60 °C (- 32 °F to 140 °F)
Ambient temperature allowed	From 0 °C to 40 °C (- 32 °F to 104 °F)
Working ambient humidity	95 % max. (non condensing)
Maximum recommended altitude	1000 m (3281 ft) above sea level
Fan voltage	400 V AC (three phase) - 50/60 Hz Independent voltage supply
Withstanding of the isolation voltage	1800 V AC in one minute
Insulation resistance	500 V AC, 10 MΩ
Feedback	Magnetic TTL encoder. Standard. C axis sinusoidal 1024 ppt SinCos™ Stegmann™ encoder. Optional.
Conformity standard	IEC 34-1

T. 1/10 General technical data. FM7, E03 and HS3 series.

FM7-□□□□-□□□□-E03 / FM7-□□□□-□□□□-HS3	
Motor type	Induction. Squirrel cage
Thermal protection (meets IEC 60034-6 standard)	NCT thermistor
Level of vibration (meets IEC 60034-14 standard)	V3 (standard)
Type of construction (meets IEC 60034-7 standard)	Horizontal: IM B5 Vertical: IM V1
Electrical insulation of the winding (meets IEC 60034 standard)	Class F (155 °C / 311 °F)
Degree of protection (meets IEC 60034-5 standard)	IP 44
Storage temperature	From 0 °C to 60 °C (- 32°F to 140°F)
Ambient temperature allowed	From 0 °C to 40 °C (- 32°F to 104°F)
Working ambient humidity	95 % max. (non condensing)
Maximum recommended altitude	1000 m (3281 ft) above sea level
Fan voltage	400 V AC (three phase) - 50/60 Hz Independent voltage supply
Withstanding of the isolation voltage	1800 V AC in one minute
Insulation resistance	500 V AC, 10 MΩ
Feedback	Magnetic TTL encoder (standard)
Conformity standard	IEC 34-1



FM7/FM9

Ref.1107

General technical data of FM9 models

T. 1/11 General technical data. FM9, E01 series.

FM9-□□□□-C5C□-E01	
Motor type	Induction. Squirrel cage
Thermal protection (meets IEC 60034-6 standard)	Thermistor KTY84-130
Level of vibration (meets IEC 60034-14 standard)	V5 (standard)
Type of construction (meets IEC 60034-7 standard)	Horizontal: IM B3, IM B5, IM B35 Vertical: IM V1, IM V5, IM V15 IM V3, IM V6, IM V36
Electrical insulation of the winding (meets IEC 60034 standard)	Class F (155 °C / 311 °F)
Degree of protection (meets IEC 60034-5 standard)	IP 54
Storage temperature	From -10 °C to 60 °C (14 °F to 140 °F)
Ambient temperature allowed	From - 15 °C to + 40 °C (5 °F to 104 °F)
Working ambient humidity	80 % max. (non condensing)
Maximum recommended altitude	1000 m (3281 ft) above sea level
Fan voltage	230/400 V AC (Δ/Y) (three-phase) - 50 Hz 460 V AC (Y) (three phase) - 60 Hz Independent voltage supply
Withstanding of the isolation voltage	1200 V AC
Insulation resistance	30 MΩ
Feedback	C axis 1024 ppt sinusoidal SinCos™ Stegmann™ encoder. Standard.
Conformity standard	IEC 34-1

Notes

The F classification of the winding isolation is based on its maximum running temperature capability. This temperature is 155°C (311°F) and represents the maximum operating temperature for the winding. At this temperature, if the motor were running in a clean and dry environment for up to 40 hours a week, it would have a life expectancy of 10 to 20 years before the isolation would get damaged due to heat and would no longer withstand the applied voltage.

1.

DESCRIPTION

General characteristics



FM7/FM9

Ref.1107

1.5 Temperature sensors

1.5.1 Simple NTC thermistor

The temperature sensor installed in FM7 motors is a simple thermistor with a negative temperature coefficient (NTC). It works in the temperature range between -50 °C (-58 °F) and 200 °C (392 °F).

T. 1/12 Characteristics of the temperature sensor.

Sensor type	NTC thermistor
Resistance at 20°C (68 °F)	10 kΩ
Resistance at 100°C (212°F)	750 Ω
Sensor connection	Feedback cable

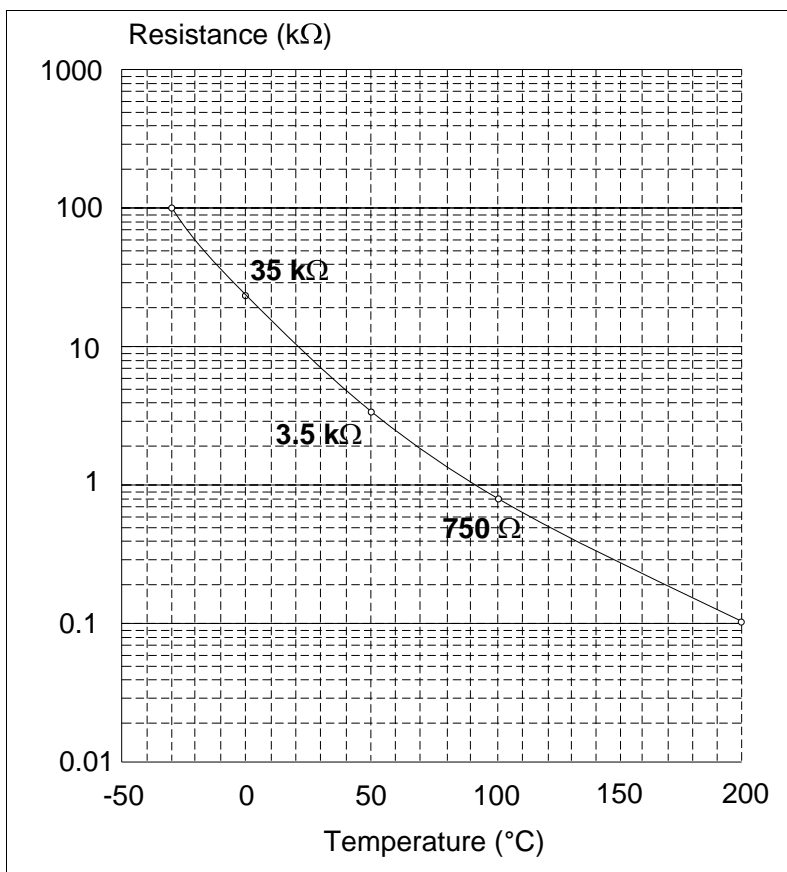

F. 1/4

Characteristics of the simple NTC thermistor. Resistance - temperature.



DESCRIPTION
Temperature sensors



FM7/FM9

Ref.1107

1.5.2 KTY84-130 thermistor

The temperature sensor in FM9 is a KTY84-130 thermistor used as thermal protection of the motor and it is located in the stator winding. It has a positive temperature coefficient (PTC) and they should be used in control and measurement systems within a range between -40°C (-40°F) and +300°C (+572°F).

1.
DESCRIPTION
Temperature sensors

T. 1/13 Characteristics of the temperature sensor.

Sensor type	KTY84-130
Approx. resistance at 20°C (68 °F)	581 Ω
Approx. resistance at 100°C (212°F)	1000 Ω
Sensor connection	Feedback cable
Motor series	In all FM9 models

The following figure shows the graph of the resistance variation of the sensor as a function of the ambient temperature (average values):

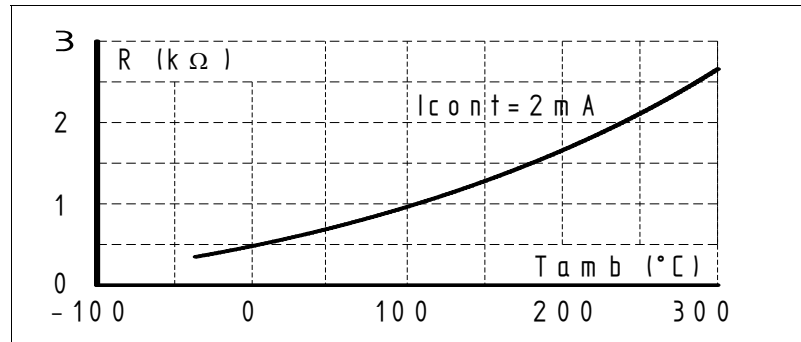

F. 1/5

KTY84-130 sensor resistance depending on room (ambient) temperature.

WARNING. The two wires of the temperature sensor are included in the feedback cable EEC or EEC-SP and it will be connected to the corresponding connector of the drive.



WARNING. The temperature sensor KTY84-130 has polarity. If you wish to manufacture your own feedback cable, make sure that the polarity is correct when soldering these two wires to the corresponding pins of the connector. See the motor feedback connector diagrams later on.



FM7/FM9

Ref.1107

1.6 Feedback devices

1.6.1 Magnetic TTL encoder

Standard feedback device in all FM7 spindle motors. It consists of a magnetic disk used as a position detector. There are three feedback signals. Two signals for the A and B phases of 1024 pulses per turn and one pulse per turn (C signal) to indicate the starting position.

The following diagram shows the relationship between the encoder configuration and the output phase when turning the shaft clockwise (CW).

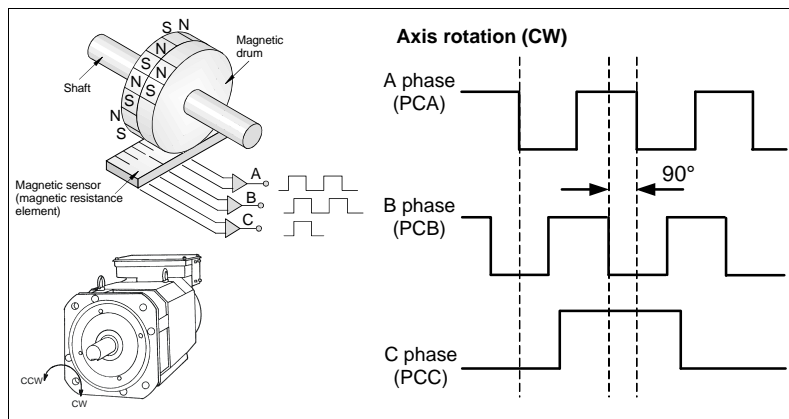

F. 1/6

Magnetic TTL encoder configuration. Output phases.

Feedback direction

The convention of the motor shaft turning direction is established according to:

Shaft turning convention	CW (+ turning direction)	CCW (turning direction -)
--------------------------	--------------------------	---------------------------

1.6.2 C axis SinCos encoder

It is the optional feedback device of the E01 (except for the FM7-E600 which is the standard feedback device) and E02 series of FM7 spindle motors. It is also the standard feedback device in the E01 series of FM9 spindle motors. It consists of a non-magnetic disk used as a position detector. There are four feedback signals. Two reference signals RefSin and RefCos and two Sin and Cos signals of 1024 pulses per turn whose composition determines the absolute position of the axis per turn.

The following diagram shows the relationship between the configuration of the C axis SinCos encoder and the output phase when turning the shaft clockwise (CW):

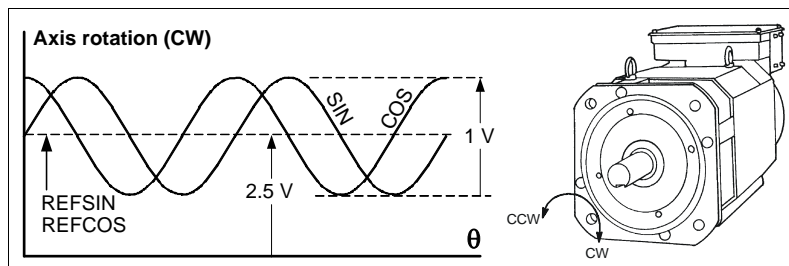

F. 1/7

C axis SinCos™ encoder configuration. Output phases.

Feedback direction

The convention of the motor shaft turning direction is established according to:

Shaft turning convention	CW (+ turning direction)	CCW (turning direction -)
--------------------------	--------------------------	---------------------------

1.

DESCRIPTION
Feedback devices



FM7/FM9

Ref.1107

ELECTRICAL CHARACTERISTICS

2

2.1 Definitions

Maximum turning speed allowed.
 n_{max} .

The maximum speed allowed n_{max} is determined by mechanical design (bearing designed in terms of fatigue, short-circuit ring of the squirrel-cage rotor) and electrical design (restricting voltage characteristics).



Never exceed this speed value !

Maximum permanent turning speed.
 n_1 .

It is the maximum speed allowed in permanent mode without any speed duty cycle.

Duty cycle S1.
Continuous duty cycle.

Operation with constant load long enough for the motor temperature to stabilize. Meets the EN 60034-1 standard.

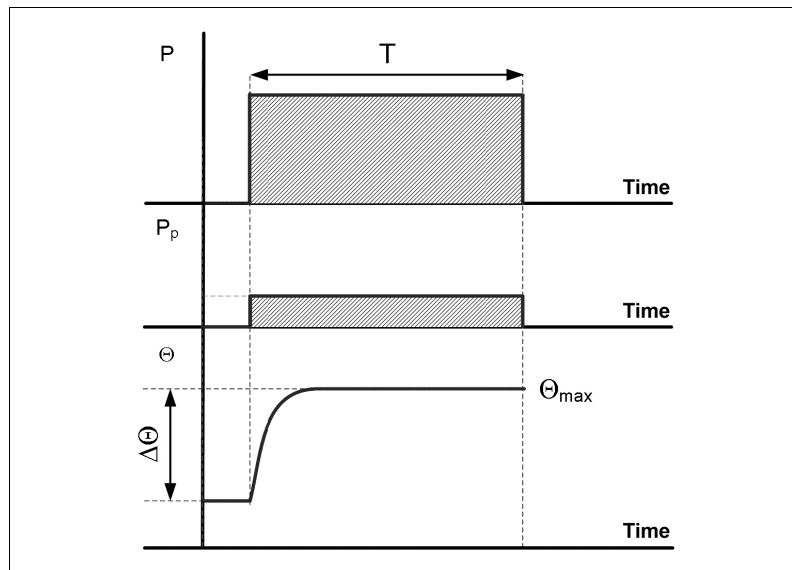

F. 2/1

Continuous duty S1.

T	Cycle duration
P	Power of the load
P_p	Electrical power lost
$\Delta\Theta$	Temperature increase over room temperature
Θ_{max}	Maximum temperature that the motor can reach without jeopardizing its insulation



FM7/FM9

Ref.1107

**S6 duty.
Intermittent
duty cycle.**

Uninterrupted periodic service with intermittent load, also called continuous service with intermittent load. It consists of a succession of identical cycles that have a constant-load period and another one without load, there are no rest intervals nor stop intervals. If no other value is indicated, the load duty cycle will be referred to a time of 10 minutes. Meets the EN 60034-1 standard. Hence:

S6 -40% $t_c = 4$ minutes with load
 $t_v = 6$ minutes without load

2.

ELECTRICAL CHARACTERISTICS
 Definitions

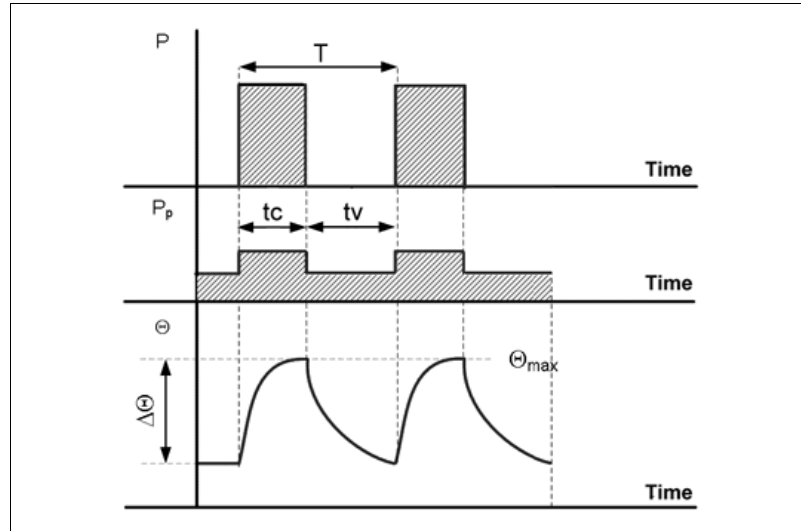

F. 2/2

Periodic uninterrupted duty cycle with intermittent load S6.

T	Cycle duration
t_c	Load time
t_v	Time without load
t_c / T	Running factor (e.g. 4 min / 10 min = 0.4) → running f.: 40%
P	Power of the load
P_p	Electrical power lost
$\Delta\Theta$	Temperature increase over room temperature
Θ_{max}	Maximum temperature that the motor can reach without jeopardizing its insulation.

Motor limits

On induction motors, the speed and power values are limited by thermal and mechanical reasons. The maximum current is only limited by the thermal characteristics of the motor windings.

Thermal limitation

Heat losses are stored in the motor and dissipated by cooling systems. The motor temperature depends on, among other things, the load duty.

Never exceed the critical temperature of the motor !

The characteristics for continuous duty S1 and intermittent duty S6-40% define the outputs allowed for a room temperature of up to 40°C (104°F). For this case, the temperature increase of the winding is 100°C (302°F).

Mechanical limitation

Never exceed the mechanical speed limit (n_{max}) because it could damage the bearings !



FM7/FM9

Ref.1107



2.2 Operating modes

We now define the operating modes of the motor shown in the figure with the power/speed and torque/speed graphs and identifying the zones where they are established. The behavior characteristics of the motor will be different depending on the zone where its operating point falls into.

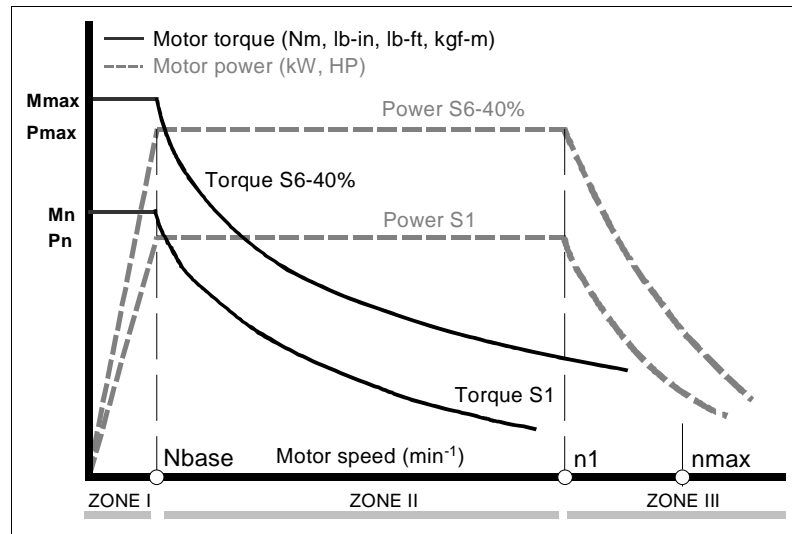

F. 2/3

Operating modes. Power and torque characteristics according to speed.

2.2.1 Operating zones

ZONE I. Constant torque range.

This zone is set from the resting state (0 rpm) to the rated operation point (rated or base speed).

The torque developed by the motor matches the rated torque M_n and is constant in the whole zone. Its value is obtained as a result from the rated power P_N generated by the motor (directly proportional to the current circulating through the rotor until reaching the rated operating point) divided by its corresponding turning speed.

The power developed by the motor is directly proportional to the turning speed up to the rated operating point where it reaches its rated power P_n .

ZONE II. Constant power range.

This zone is defined as the constant power zone and is set from the rated operation point up to where the motor voltage reaches the maximum available.

The torque decreases inversely proportional to the speed.

Power remains constant.

From the motor base speed on, the torque decreases. The torque cannot be kept constant in the whole range because of the limitation set by the design point. Voltage is limited beyond the base frequency. Power is kept constant and this means that an increase in speed means a decrease in torque, so their product provides a constant power value.

ZONE III.

This zone begins when the voltage at the terminals of the motor has reached the maximum voltage that the drive that governs it can provide.

The torque decreases with the square of the speed.

Power decreases with speed.

2.3 Influence of supply voltage

The supply voltage of the bus sets one of the electrical limitations on the operation mode of the motor.

In operating ZONE II, power remains constant. However, in ZONE III, it decreases as the speed increases. Knowing that in most spindle applications the operation point is kept in ZONE II, constant power, this zone should be as wide as possible.

Going from ZONE II to ZONE III takes place due to the lack of enough voltage to keep compensating for the voltage drop on the stator impedance.

Therefore, in general, the higher the voltage the drive can provide, the wider ZONE II, constant power, will be.

When the motor's operation point is located in ZONE III and it does not provide the necessary power, select a larger motor or increase the voltage supplied to the drive.

See figure F. 2/4 that shows these limitations.

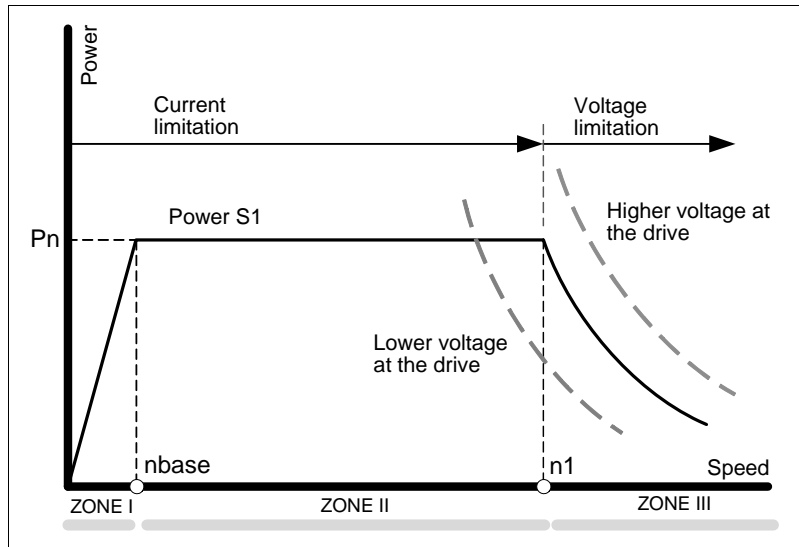

F. 2/4

Limited by voltage.

At first, when wishing to get high cutting torque at low speed, a speed gear reduction was used in order to increase the spindle torque. This caused a higher price and complicated the design of the system. A second option was to use a larger motor, hence increasing the cost.

Likewise, obtaining a high torque at high speed meant a current increase due to the voltage limitation (maximum limited voltage) to keep the VI product constant in ZONE II (constant power zone) and required a larger drive, hence higher cost.

Thanks to the Y-Δ (star-triangle) winding switching technology described next, it is possible to cover all the needs mentioned earlier without having to resort to the solutions mentioned earlier.

2.
ELECTRICAL CHARACTERISTICS
Influence of supply voltage



FM7/FM9

Ref.1107

2.4 Y-Δ winding connection switching

Only the E03 and HS3 series of asynchronous spindle motors of the FM7 family have a 6-lead winding that allows star-delta switching of the connection.

2.4.1 Y winding and D winding

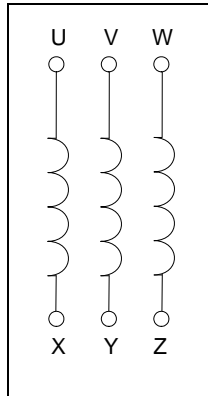

Built

6-Lead winding motor where U, V and, W are at one end of the winding and X, Y, Z at the other end.

Usage

A 6-lead winding may be connected according to a configuration:

□ In star

□ In triangle

See figure F. 2/6.

F. 2/5

6-lead winding.

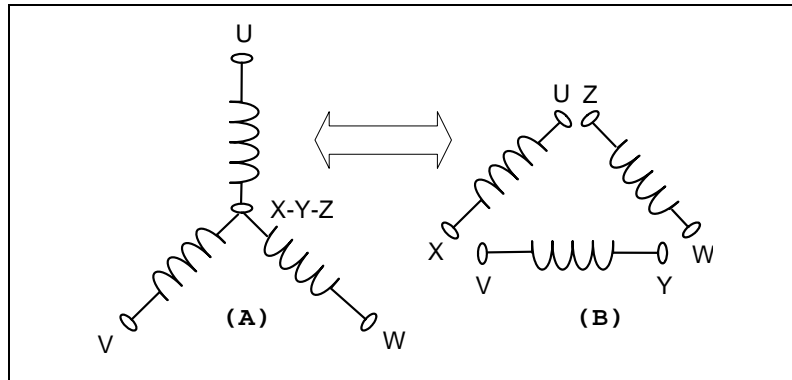

F. 2/6

Possible winding connections. **A.** Star (Y). **B.** Triangle (Δ).

A Y winding connection can provide high torque at low speeds and a Δ winding connection low torque at high speeds.

Y (star) connection

This connection is commonly used for AC induction motors. The motor torque and base speed depend on the motor impedance Z.

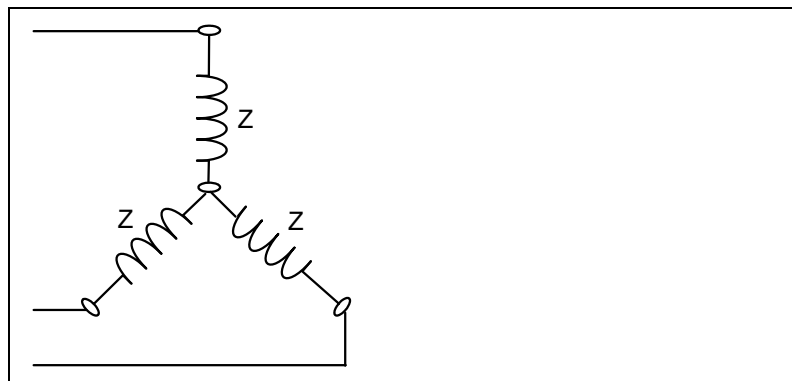

F. 2/7

Y (star) connection. Impedance Z.

2.
ELECTRICAL CHARACTERISTICS
Y-D winding connection switching



FM7/FM9

Ref.1107

2.

ELECTRICAL CHARACTERISTICS
Y-D winding connection switching

The voltage/frequency ratio (V/f) of this connection is based on the motor operation point. At the high frequency, a power drop occurs due to motor impedance.

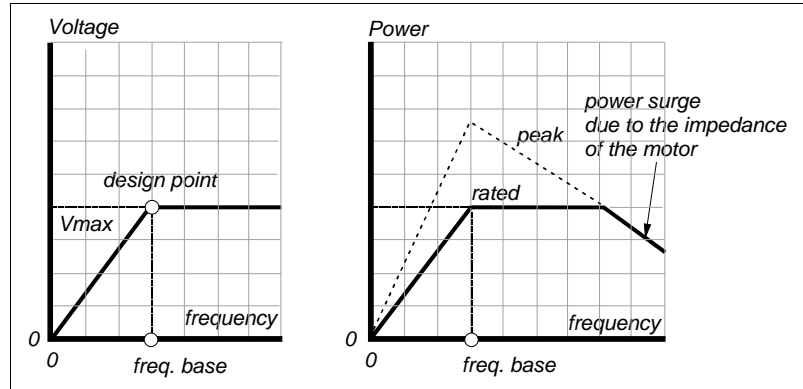

F. 2/8

Voltage/frequency and power/frequency diagrams.

Δ (triangle) connection

When using this connection, the impedance Z of the motor is much lower than in the previous case. The impedance equivalent to Z in a Y connection is $Z/3$.

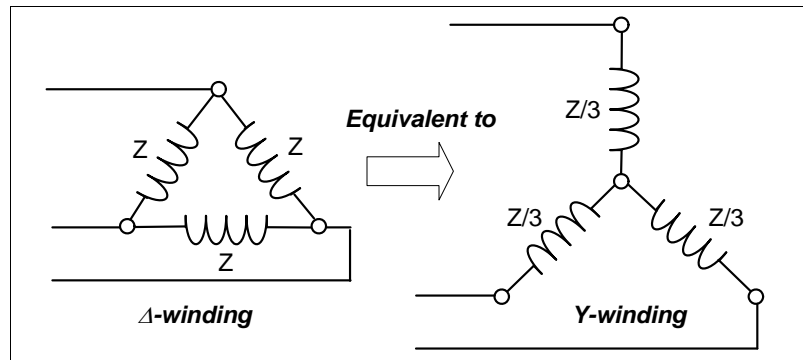

F. 2/9

Δ (triangle) connection. Equivalent impedance in a Y connection.

A lower motor impedance means higher base frequency (base speed) and higher maximum frequency, but remember that the maximum voltage is limited beyond the base speed.

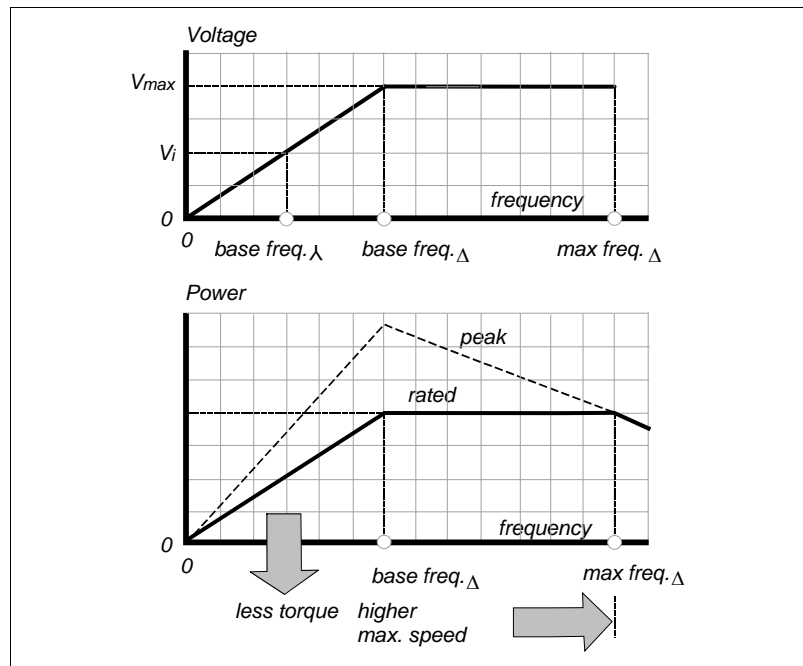

F. 2/10

Comparison diagrams of voltage/frequency and power/frequency for delta connection.



FM7/FM9

Ref.1107

2.4.2 Comparison charts F/f and M/f depending on Y-D connection

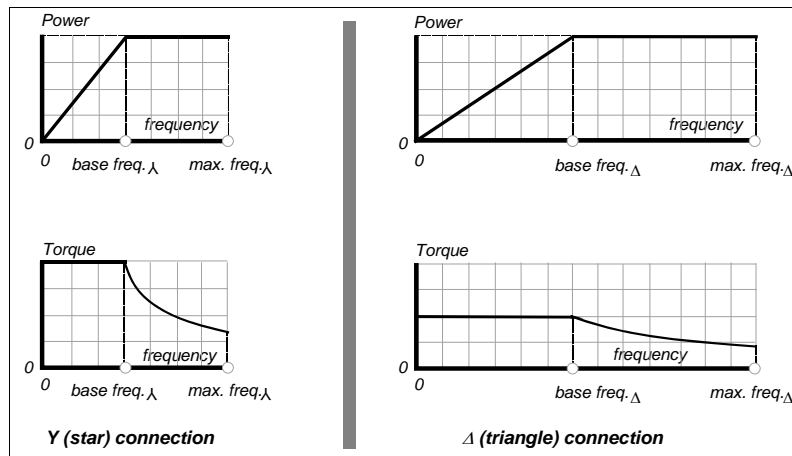

F. 2/11

Comparison charts P/f and M/f depending on Y or Δ connection.

It is therefore, interesting to be able to combine the advantages of both windings, i.e., to use Y-winding at low speed to provide high torque and delta winding at high speed.

The Y-Δ winding change will be carried out through two external magnetic contactors placed between the drive and the motor. If the user has a software version 06.18 or higher, this switch can be made without stopping the motor (at non-zero speed), in other cases, it will have to be done stopping the motor (zero speed).

The winding change provides high torque and wide constant power range with relatively small size drive.

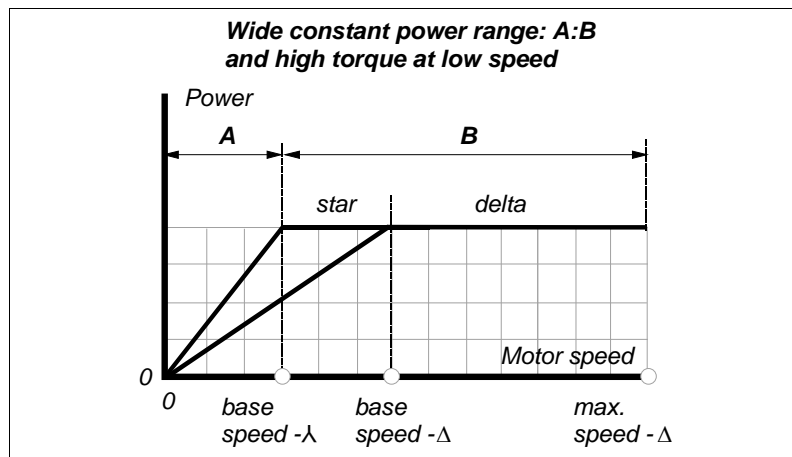

F. 2/12

Power/speed graphs applying the winding connection change.

For further details on the connection diagram of the "motor-contactors- drive" system in the electrical cabinet, see the relevant section in the installation chapter of this manual.

2.

ELECTRICAL CHARACTERISTICS
Y-D winding connection switching



FM7/FM9

Ref.1107

2.5 Technical data. Power/torque-speed graphs

This section describes the power and torque graphs for the S1 and S6 40% duty cycles (cycle times of 10 minutes).

Remember that when mentioning an S6 cycle in this manual, it always refers to this cycle with a 40% running factor.

The tables that come with the graphs give the most important technical data that characterize each model of this family of motors.

This section also classifies the FM7 and FM9 spindle motors by series. Therefore, the user must check his motor with the series it belongs to in order to find the specific power / torque - speed graph for that motor.

Remember that there are five series:

- FM7-□□□□-□□□□-E01
- FM9-□□□□-C5C□-E01
- FM7-□□□□-□□□□-E02
- FM7-□□□□-S1D0-E03
- FM7-□□□□-S1D0-HS3

All the models belonging to the 5 series have 2 pairs of poles (4 poles).

The maximum power and speed ranges covered by each series were already shown in chapter 1. Description.

Explanatory notes

- Motors whose maximum speed equal to or higher than 8000 rpm should have a keyless shaft and should be balanced under these conditions.
- Chapter 6 (selection) describes how to select the modular or compact drive that will be governing the motor. Selection. Hence, the motor - drive association for all the models has been already defined.
- All AC motors of the FM7/FM9 families governed by main spindle drives must be continuously ventilated while running, regardless of the duty cycle demanded by the application.
- The windings of the FM7 of the FM7-□□□□-□□□□-E01 and E02 series have a permanent Delta (triangle) connection.

Note. The windings of the FM7 motors - E01 and E02 series - cannot have a Y (star) connection. They are internally connected in triangle and cannot be changed.

- The windings of the FM7 motors of the FM7-D□□□-S1D0-E03 and HS3 series may be configured either in triangle or in star using two external contactors installed between the motor and the drive.
- FM9 motor windings have a Y connection.

Symbols used

The following symbols appearing in the technical data tables mean:

▲	Y (star) connection
△	Delta (triangle) connection

The mass of the motor shown in the technical data tables appears for some models with the letters **B/P/B+P**. The values provided correspond to the approximate mass of the motor depending on whether it is flange mount (B) or foot mount (P) or flange+foot mount (B+P). Hence, for example, when only showing **B**, it corresponds to the approximate mass of the motor that can only be flange mounted.

2.

ELECTRICAL CHARACTERISTICS

Technical data. Power/torque-speed graphs



FM7/FM9

Ref.1107

2.5.1 FM7-XXXX-XXXX-E01/E02 series

T. 2/1 AC spindle motor FM7-A037-□□□□-E01/E02.

FM7-A037-□□□□-E01/E02							
Power Rated	Base speed	Rated torque	Rated current	Max. speed		Inertia	Approx. mass
				E01	E02		
Pn (kW)	nN (rpm)	Mn (N·m)	In (Arms)	nmax (rpm)		J (kg·cm ²)	B/P (kg)
3.7	1500	23.5	12.4	9000	12000	140	47/49

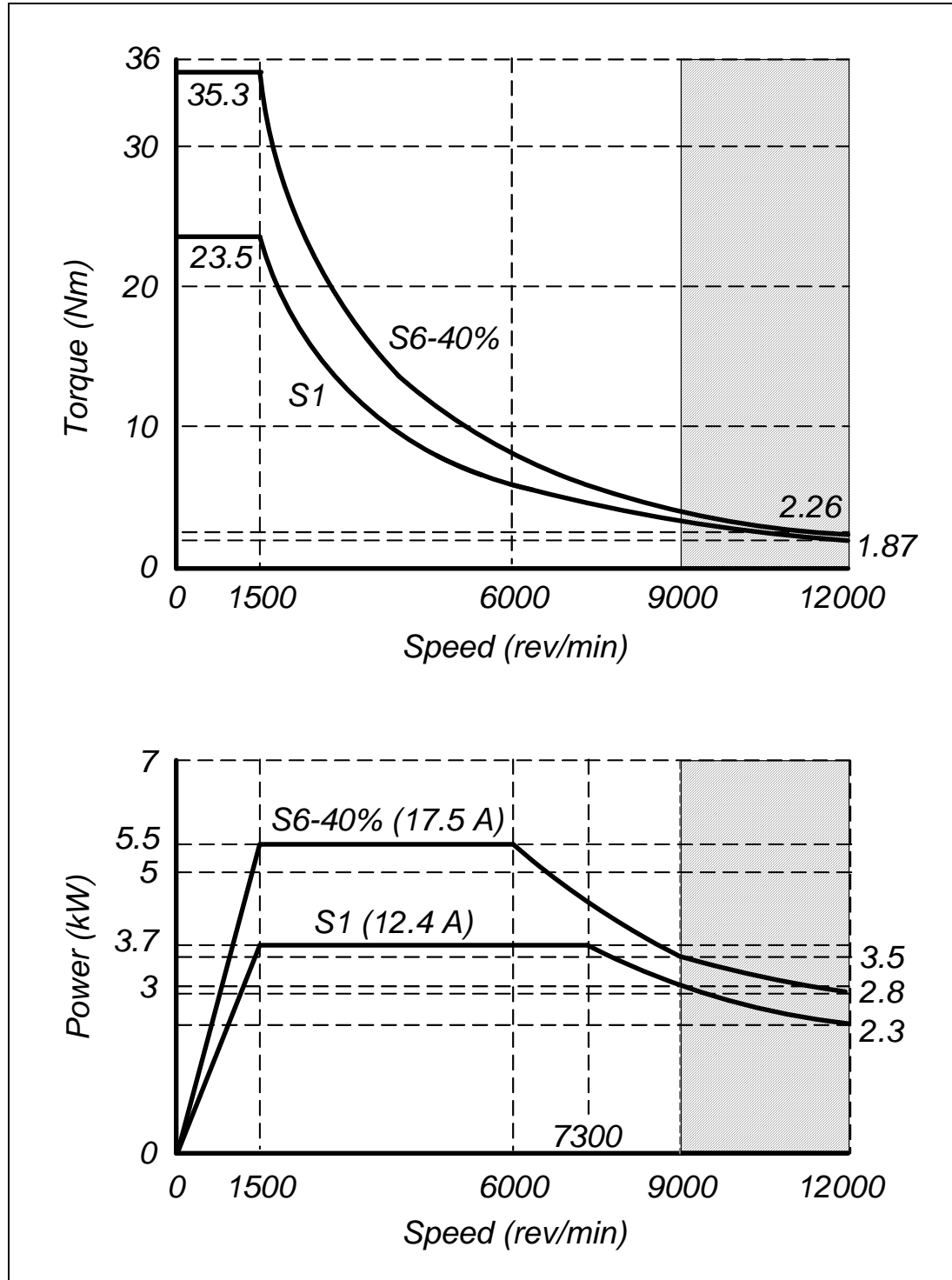

F. 2/13

Power/torque-speed graph. FM7-A037-□□□□-E01/E02.

2.

ELECTRICAL CHARACTERISTICS
 Technical data. Power/torque-speed graphs



FM7/FM9

Ref.1107

T. 2/2 AC spindle motor FM7-A055-□□□□-E01/E02.

FM7-A055-□□□□-E01/E02							
Power Rated	Base speed	Rated torque	Rated current	Max. speed		Inertia	Approx. mass
				E01	E02		
Pn (kW)	nN (rpm)	Mn (N·m)	In (Arms)	nmax (rpm)		J (kg·cm ²)	B/P (kg)
5.5	1500	35.0	14.6	9000	10000	210	52/56

2.

ELECTRICAL CHARACTERISTICS

Technical data. Power/torque-speed graphs

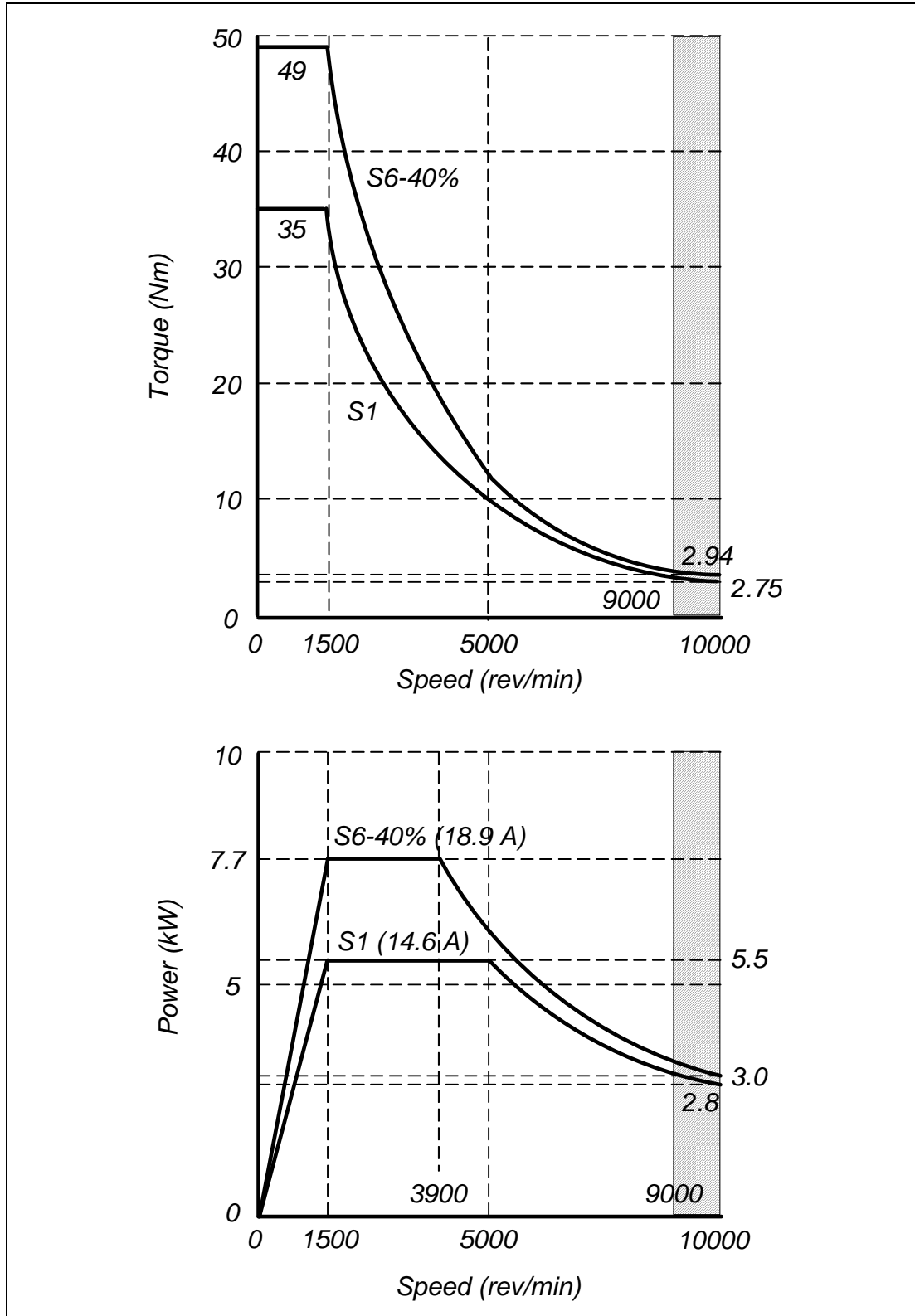

F. 2/14

Power/torque-speed graph. FM7-A055-□□□□-E01/E02.



FM7/FM9

Ref.1107

T. 2/3 AC spindle motor FM7-A075-□□□□-E01/E02.

FM7-A075-□□□□-E01/E02							
Power Rated	Base speed	Rated torque	Rated current	Max. speed		Inertia	Approx. mass
				E01	E02		
Pn (kW)	nN (rpm)	Mn (N·m)	In (Arms)	nmax (rpm)		J (kg·cm ²)	B/P (kg)
7.5	1500	47.7	19.8	9000	10000	260	59/64

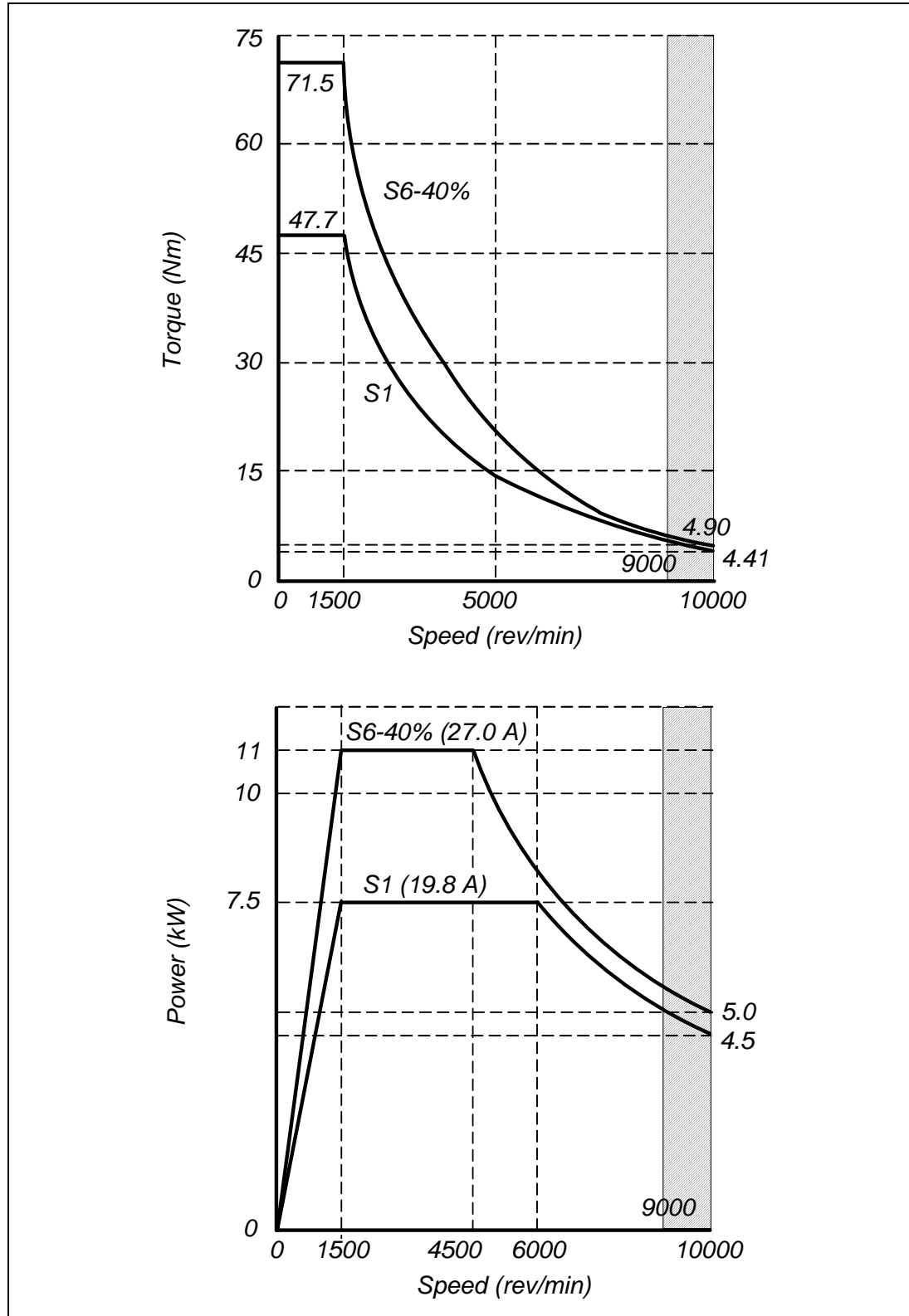

F. 2/15

Power/torque-speed graph. FM7-A075-□□□□-E01/E02.

2.

ELECTRICAL CHARACTERISTICS
 Technical data. Power/torque-speed graphs



FM7/FM9

Ref.1107

T. 2/4 AC spindle motor FM7-A090-□□□□-E01/E02.

FM7-A090-□□□□-E01/E02							
Power Rated	Base speed	Rated torque	Rated current	Max. speed		Inertia	Approx. mass
				E01	E02		
Pn (kW)	nN (rpm)	Mn (N·m)	In (Arms)	nmax (rpm)		J (kg·cm ²)	B/P (kg)
9.0	1500	57.4	25.1	9000	10000	330	68/73

2.

ELECTRICAL CHARACTERISTICS

Technical data. Power/torque-speed graphs

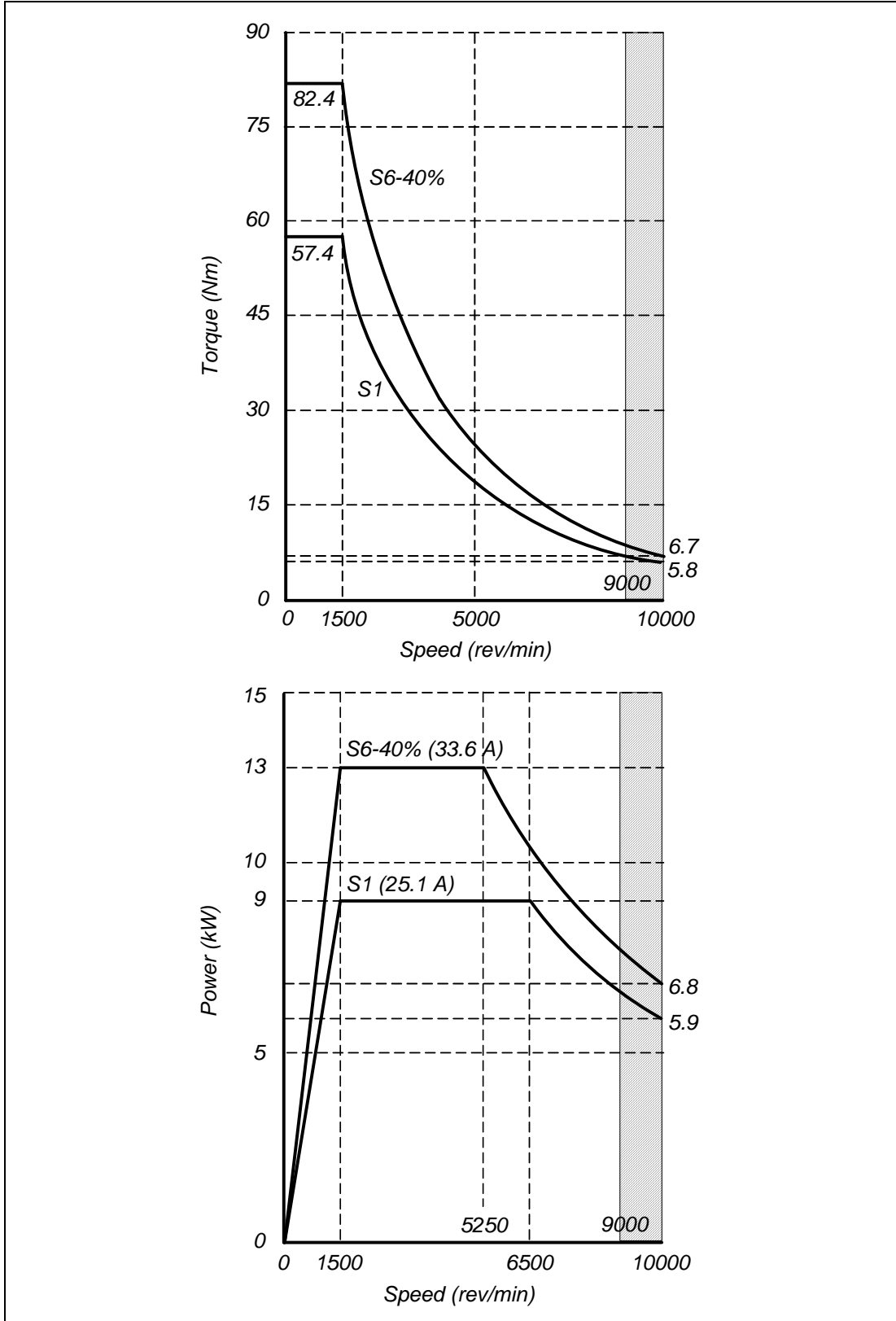

F. 2/16

Power/torque-speed graph. FM7-A090-□□□□-E01/E02.



FM7/FM9

Ref.1107

T. 2/5 AC spindle motor FM7-A110-□□□□-E01/E02.

FM7-A110-□□□□-E01/E02							
Power Rated	Base speed	Rated torque	Rated current	Max. speed		Inertia	Approx. mass
				E01	E02		
Pn (kW)	nN (rpm)	Mn (N·m)	In (Arms)	nmax (rpm)		J (kg·cm ²)	B/P (kg)
11.0	1500	70.0	27.9	9000	10000	690	94/110

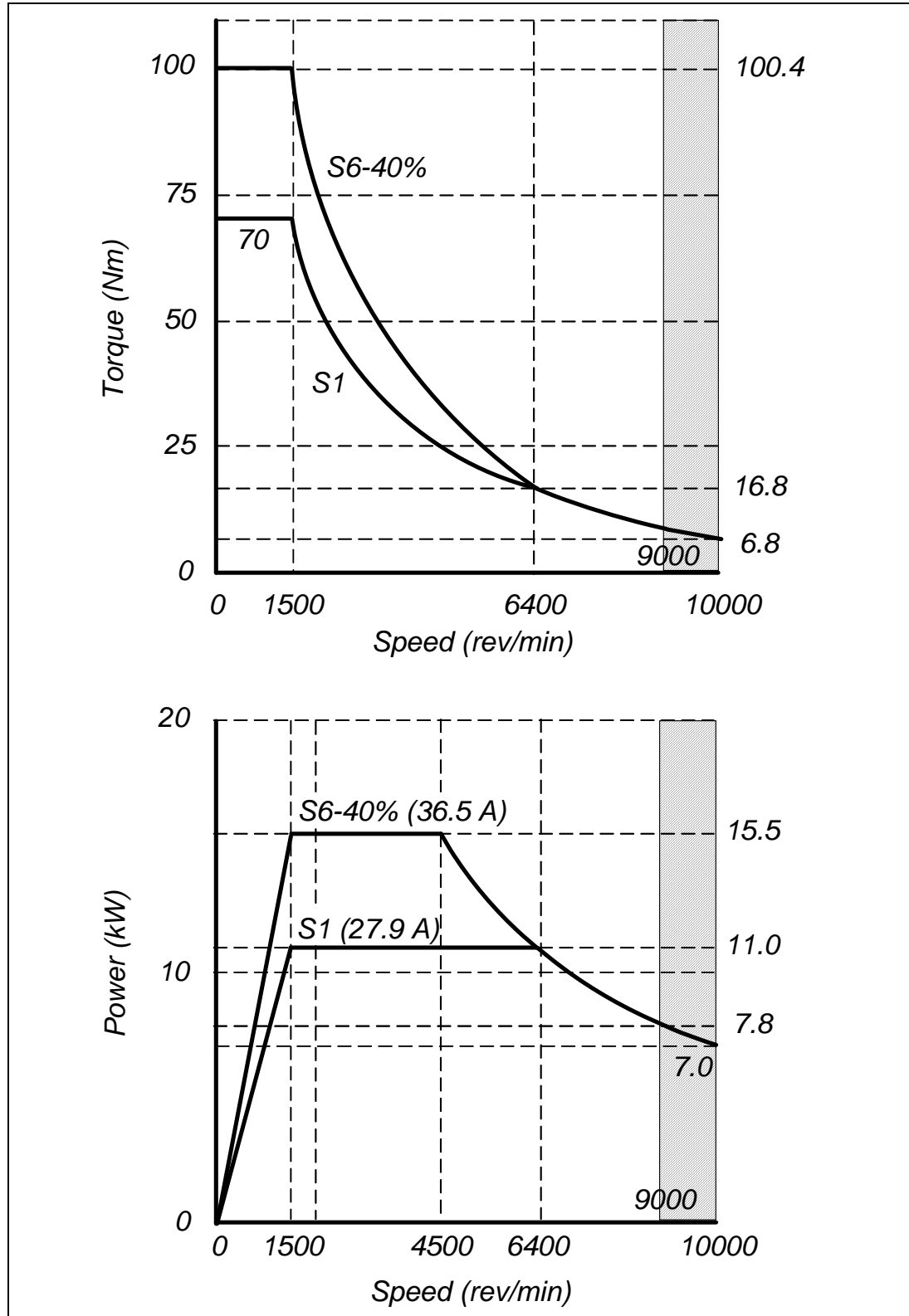

F. 2/17

Power/torque-speed graph. FM7-A110-□□□□-E01/E02.

2.

ELECTRICAL CHARACTERISTICS
 Technical data. Power/torque-speed graphs



FM7/FM9

Ref.1107

T. 2/6 AC spindle motor FM7-A150-□□□□-E01/E02.

FM7-A150-□□□□-E01/E02							
Power Rated	Base speed	Rated torque	Rated current	Max. speed		Inertia	Approx. mass
				E01	E02		
Pn (kW)	nN (rpm)	Mn (N·m)	In (Arms)	nmax (rpm)		J (kg·cm ²)	B/P (kg)
15.0	1500	95.5	39.3	8000	9000	690	94/110

2.

ELECTRICAL CHARACTERISTICS

Technical data. Power/torque-speed graphs

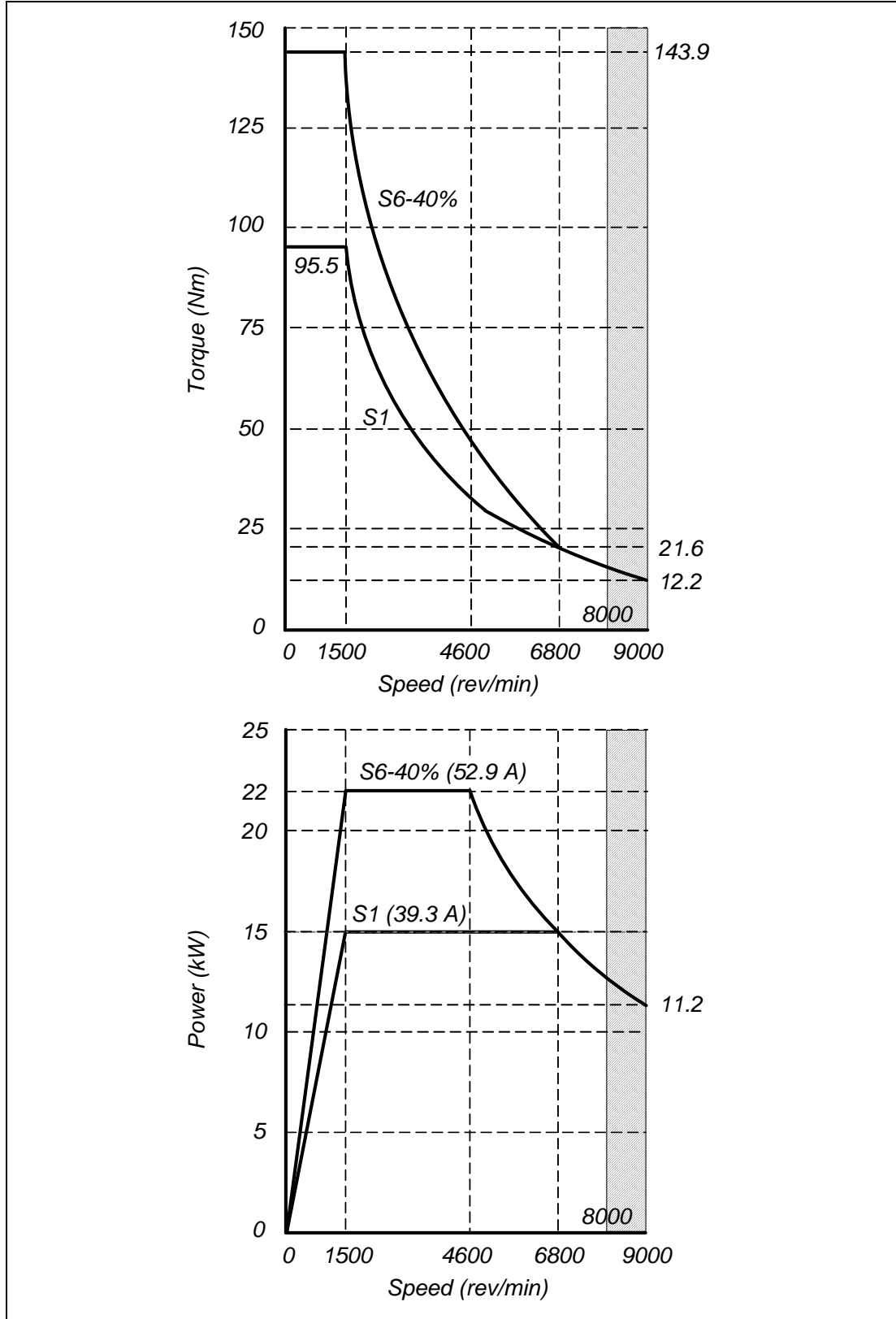

F. 2/18

Power/torque-speed graph. FM7-A150-□□□□-E01/E02.



FM7/FM9

Ref.1107

T. 2/7 AC spindle motor FM7-A185-□□□□-E01/E02.

FM7-A185-□□□□-E01/E02							
Power Rated	Base speed	Rated torque	Rated current	Max. speed		Inertia	Approx. mass
				E01	E02		
Pn (kW)	nN (rpm)	Mn (N·m)	In (Arms)	nmax (rpm)		J (kg·cm ²)	B/P (kg)
18.5	1500	117.8	47.4	8000	9000	890	120/130

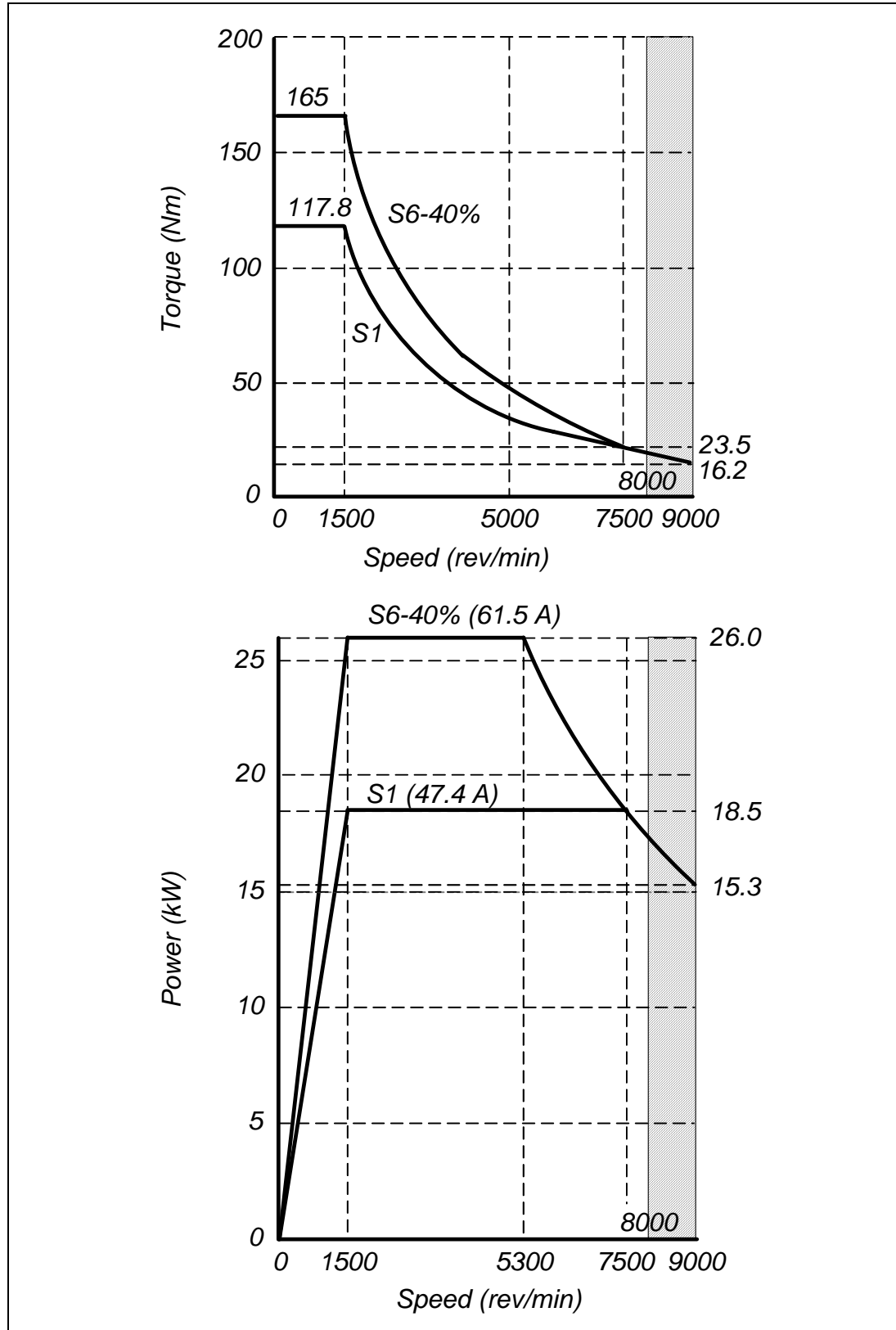

F. 2/19

Power/torque-speed graph. FM7-A185-□□□□-E01/E02.

2.

ELECTRICAL CHARACTERISTICS
 Technical data. Power/torque-speed graphs



FM7/FM9

Ref.1107

T. 2/8 AC spindle motor FM7-A220-□□□□-E01/E02.

FM7-A220-□□□□-E01/E02							
Power Rated	Base speed	Rated torque	Rated current	Max. speed		Inertia	Approx. mass
				E01	E02		
Pn (kW)	nN (rpm)	Mn (N·m)	In (Arms)	nmax (rpm)		J (kg·cm ²)	B/P (kg)
22.0	1500	140.0	61.4	8000	9000	1080	135/145

2.

ELECTRICAL CHARACTERISTICS

Technical data. Power/torque-speed graphs

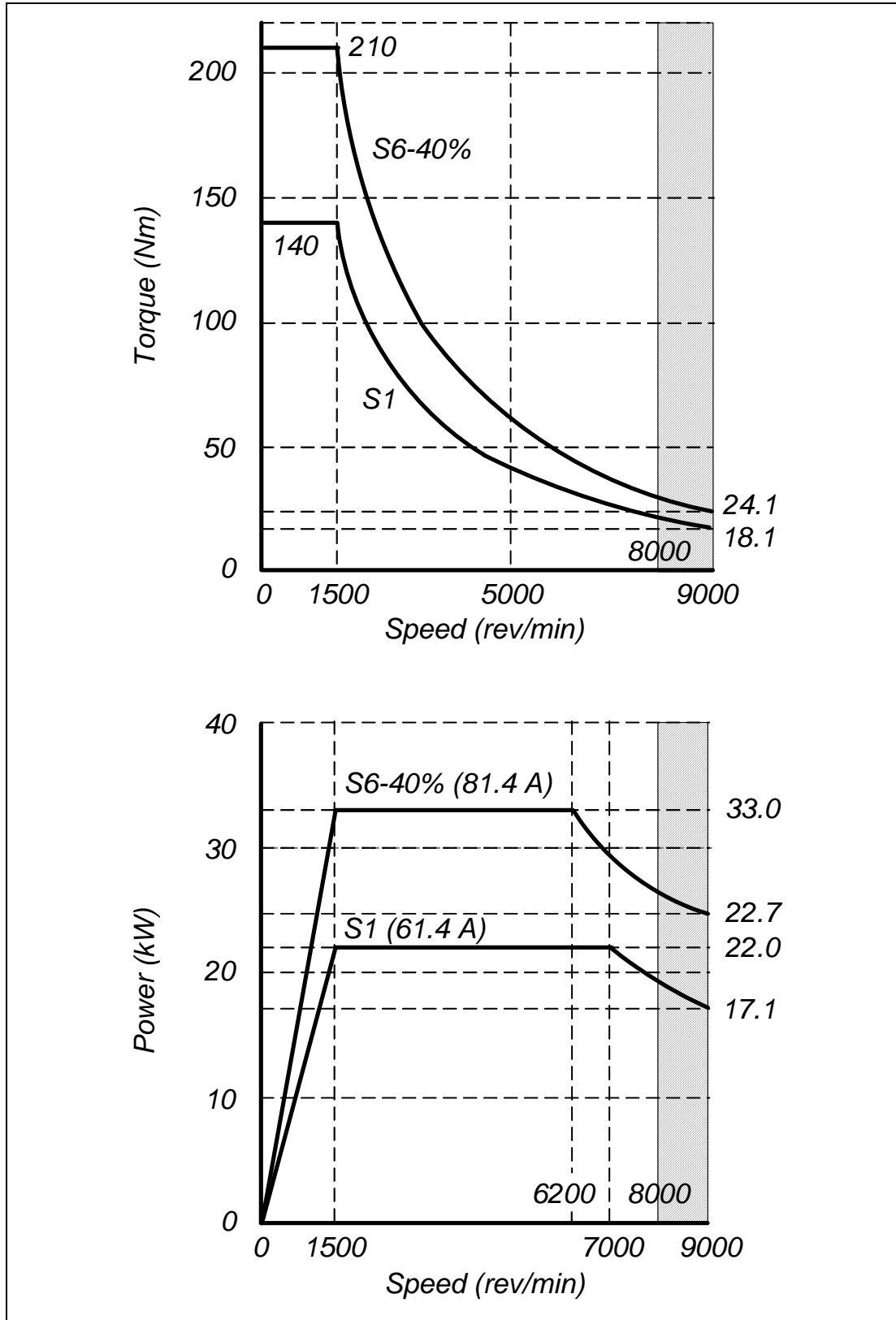

F. 2/20

Power/torque-speed graph. FM7-A220-□□□□-E01/E02.



FM7/FM9

Ref.1107

T. 2/9 AC spindle motor FM7-A300-□□□□-E01.

FM7-A300-□□□□-E01							
Power Rated	Base speed	Rated torque	Rated current	Max. speed		Inertia	Approx. mass
				E01	---		
Pn (kW)	nN (rpm)	Mn (N·m)	In (A rms)	nmax (rpm)		J (kg·cm ²)	B/P (kg)
30.0	1500	191.0	82.1	6500	---	2310	220/230

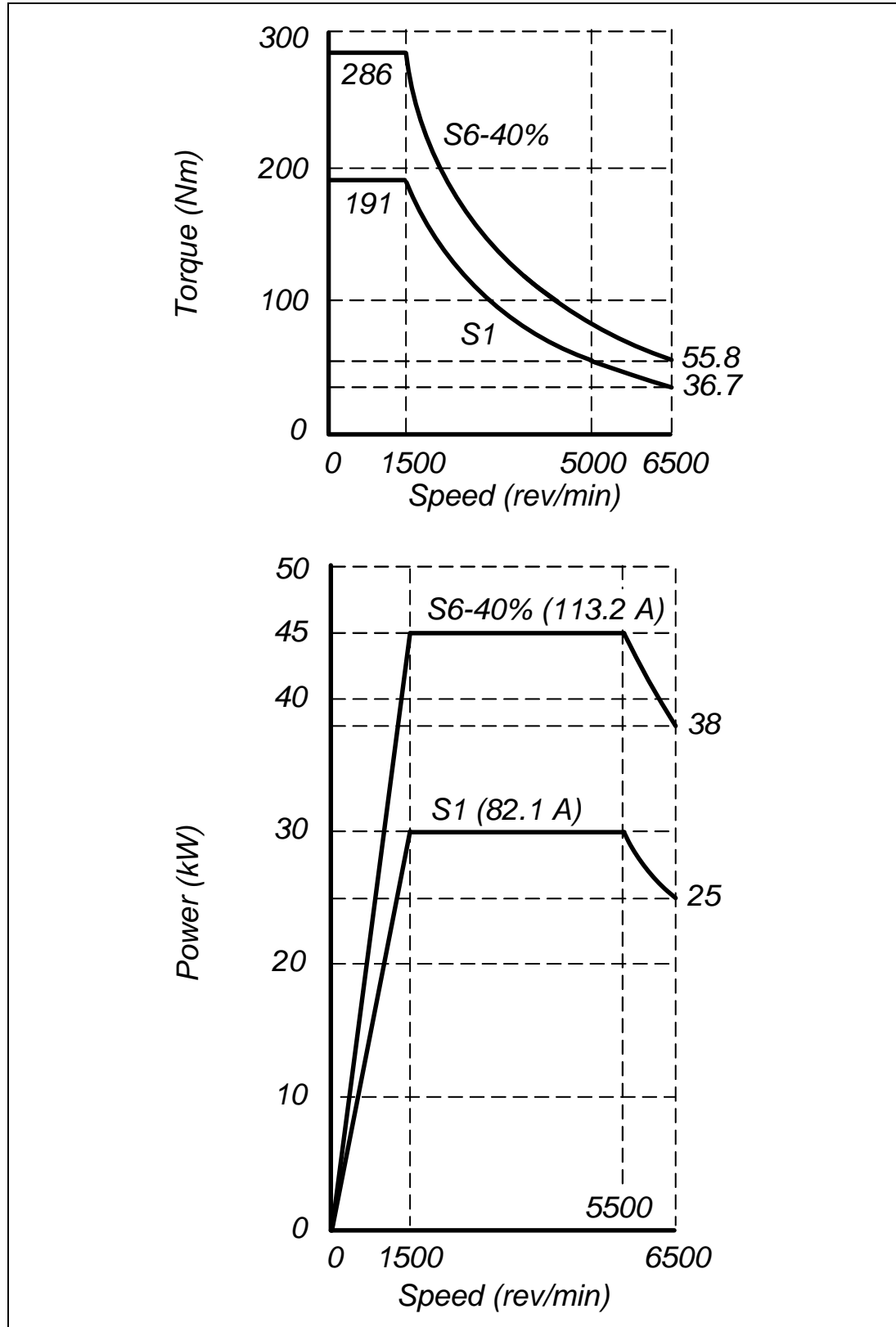

F. 2/21

Power/torque-speed graph. FM7-A300-□□□□-E01.

2.

ELECTRICAL CHARACTERISTICS
 Technical data. Power/torque-speed graphs



FM7/FM9

Ref.1107

T. 2/10 AC spindle motor FM7-A370-□□□□-E01.

FM7-A370-□□□□-E01							
Power Rated	Base speed	Rated torque	Rated current	Max. speed		Inertia	Approx. mass
				E01	---		
Pn (kW)	nN (rpm)	Mn (N·m)	In (Arms)	nmax (rpm)		J (kg·cm ²)	B/P (kg)
37.0	1500	235.0	89.9	6500	---	2660	250/260

2.

ELECTRICAL CHARACTERISTICS
 Technical data. Power/torque-speed graphs

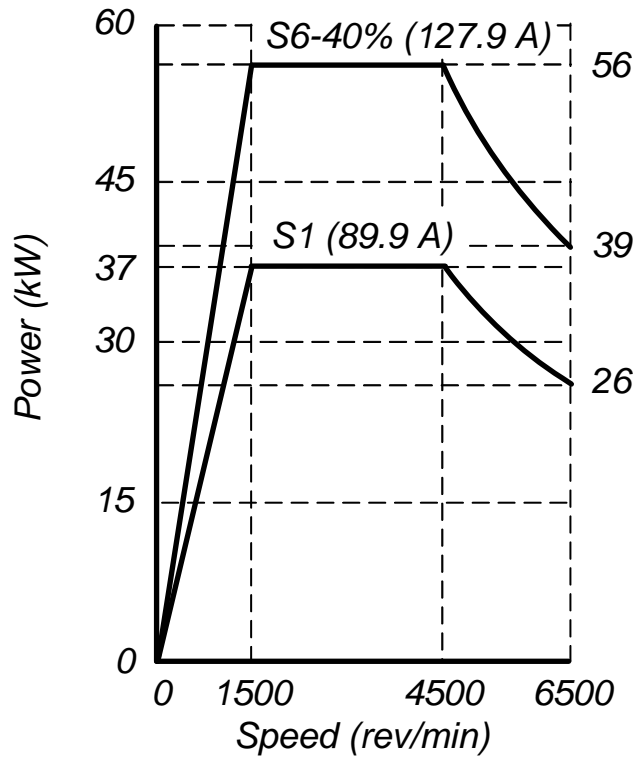
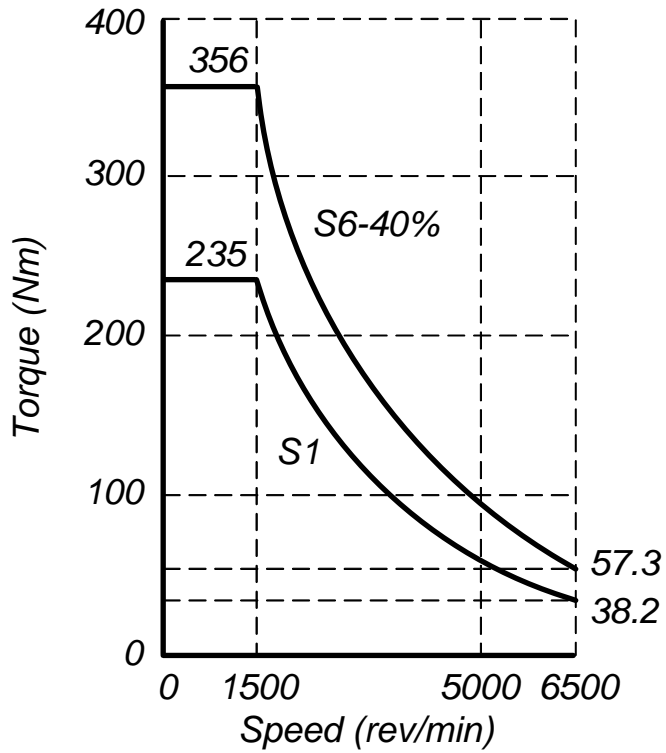

F. 2/22

Power/torque-speed graph. FM7-A370-□□□□-E01.



FM7/FM9

Ref.1107

T. 2/11 AC spindle motor FM7-A510-□□□□-E01/E02.

FM7-A510-□□□□-E01/E02							
Power Rated	Base speed	Rated torque	Rated current	Max. speed		Inertia	Approx. mass
				E01	E02		
Pn (kW)	nN (rpm)	Mn (N·m)	In (Arms)	nmax (rpm)		J (kg·cm ²)	B/P (kg)
51.0	1500	325.0	115.1	5000	6000	4730	340/350

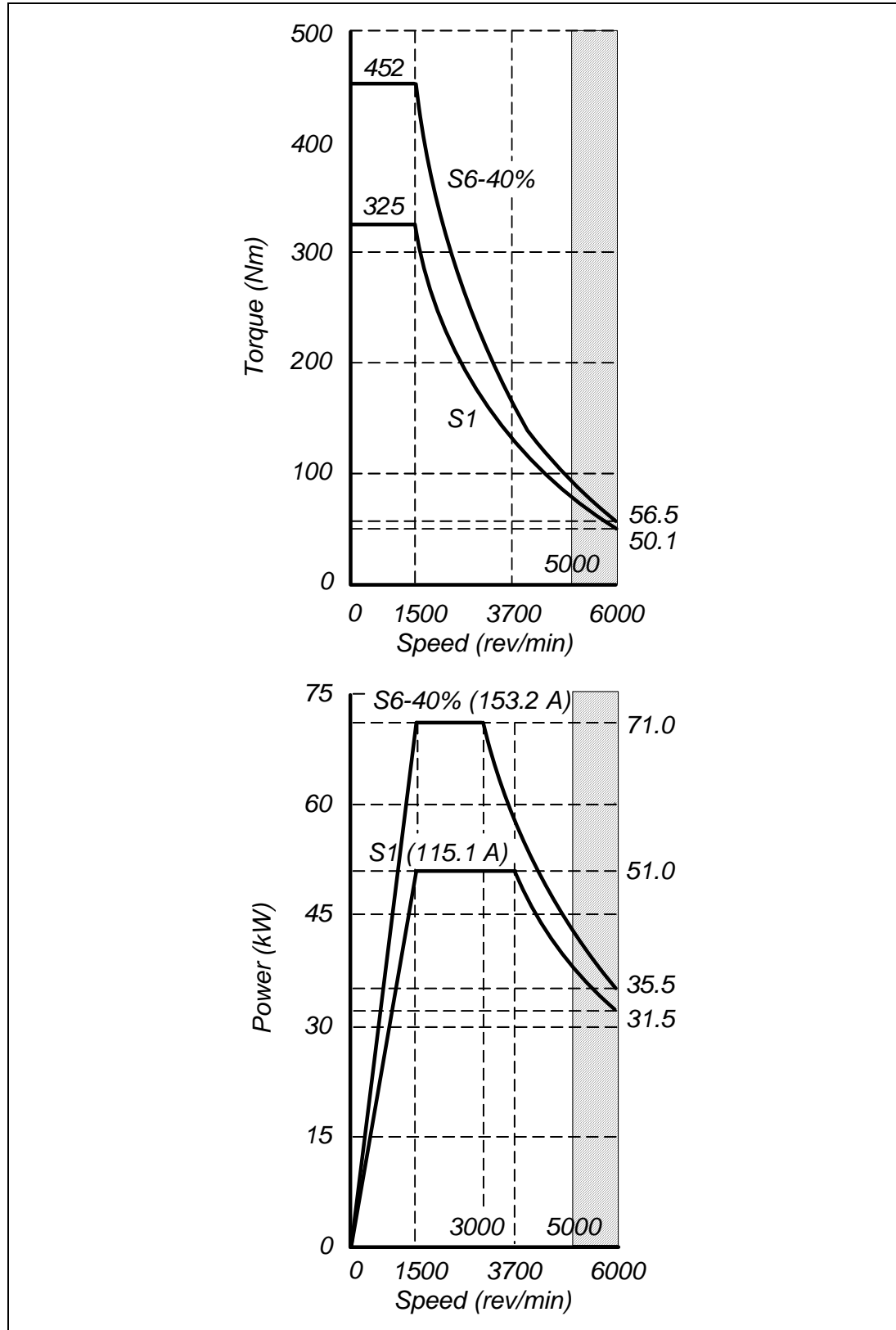

F. 2/23

Power/torque-speed graph. FM7-A510-□□□□-E01/E02.

2.

ELECTRICAL CHARACTERISTICS
 Technical data. Power/torque-speed graphs



FM7/FM9

Ref.1107

T. 2/12 AC spindle motor FM7-B120-□□□□-E01/E02.

FM7-B120-□□□□-E01/E02							
Power Rated	Base speed	Rated torque	Rated current	Max. speed		Inertia	Approx. mass
				E01	E02		
Pn (kW)	nN (rpm)	Mn (N·m)	In (Arms)	nmax (rpm)		J (kg·cm ²)	B/P (kg)
12.0	1000	114.6	35.0	8000	9000	890	120/130

2.

ELECTRICAL CHARACTERISTICS
 Technical data. Power/torque-speed graphs

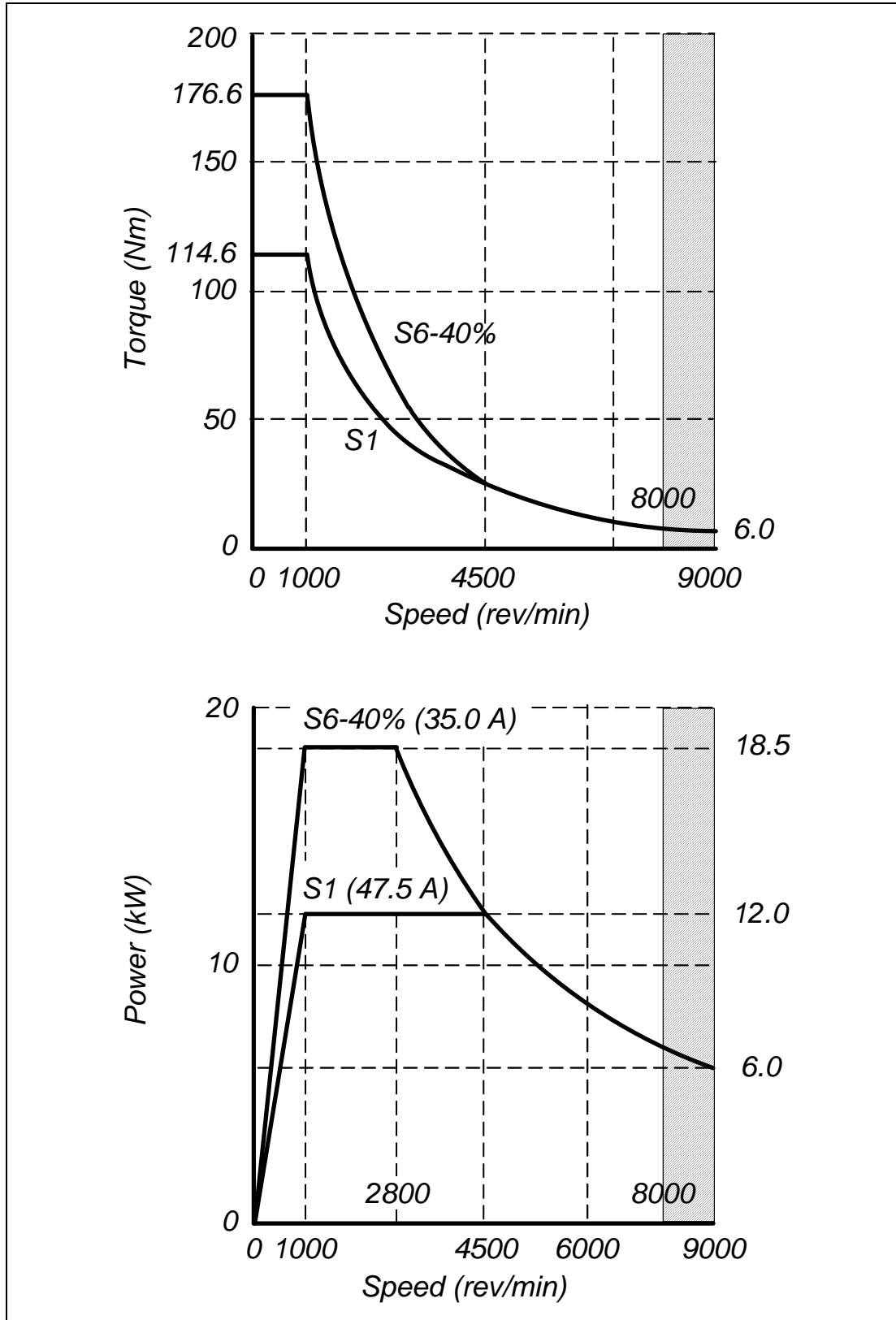

F. 2/24

Power/torque-speed graph. FM7-B120-□□□□-E01/E02.



FM7/FM9

Ref.1107

T. 2/13 AC spindle motor FM7-B170-□□□□-E01/E02.

FM7-B170-□□□□-E01/E02							
Power Rated	Base speed	Rated torque	Rated current	Max. speed		Inertia	Approx. mass
				E01	E02		
P _n (kW)	n _N (rpm)	M _n (N·m)	I _n (Arms)	n _{max} (rpm)		J (kg·cm ²)	B/P (kg)
17.0	1000	162.3	47.2	8000	9000	1080	135/145

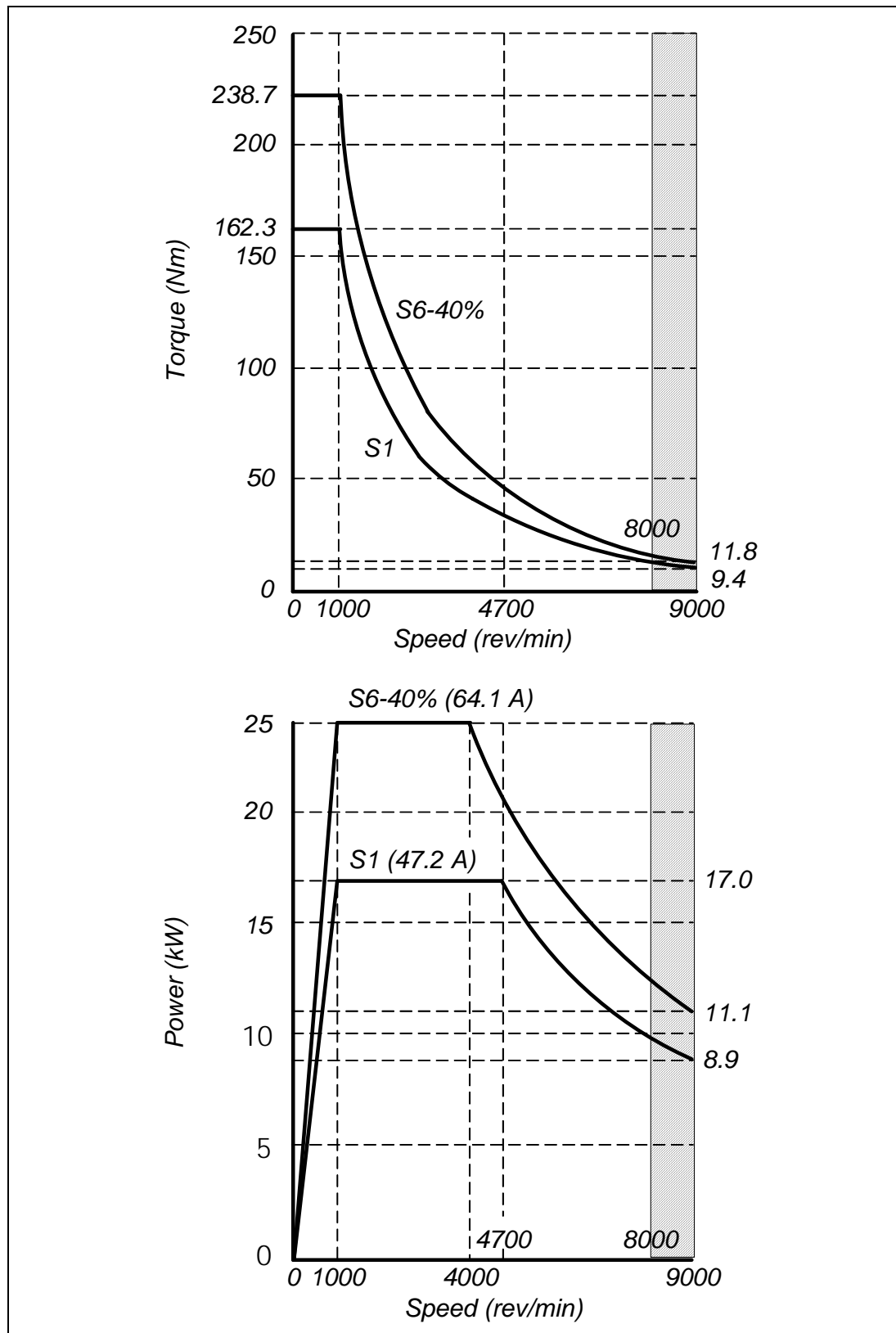

F. 2/25

Power/torque-speed graph. FM7-B170-□□□□-E01/E02.

2.

ELECTRICAL CHARACTERISTICS
 Technical data. Power/torque-speed graphs



FM7/FM9

Ref.1107

T. 2/14 AC spindle motor FM7-B220-□□□□-E01.

FM7-B220-□□□□-E01							
Power Rated	Base speed	Rated torque	Rated current	Max. speed		Inertia	Approx. mass
				E01	---		
Pn (kW)	nN (rpm)	Mn (N·m)	In (Arms)	nmax (rpm)		J (kg·cm ²)	B/P (kg)
22.0	1000	210.0	64.9	6500	---	2310	220/230

2.

ELECTRICAL CHARACTERISTICS

Technical data. Power/torque-speed graphs

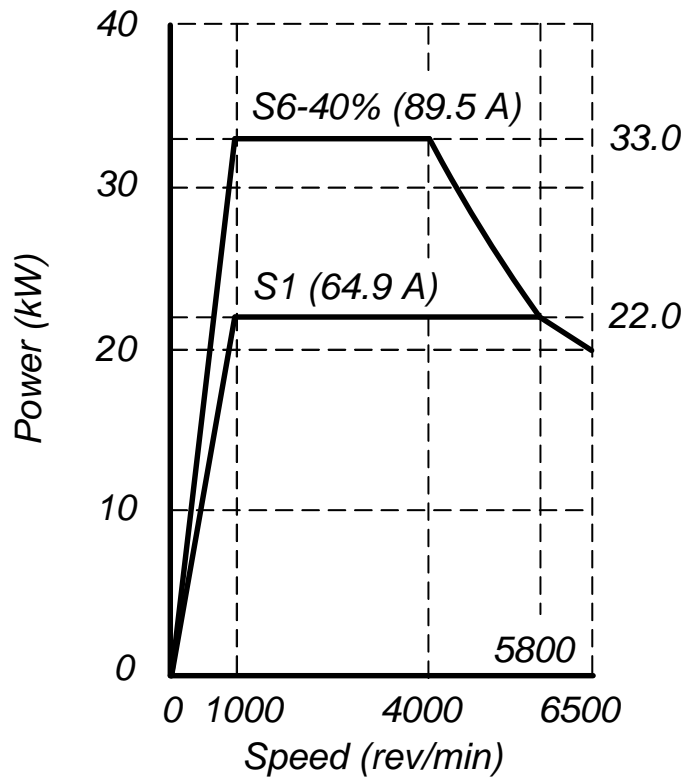
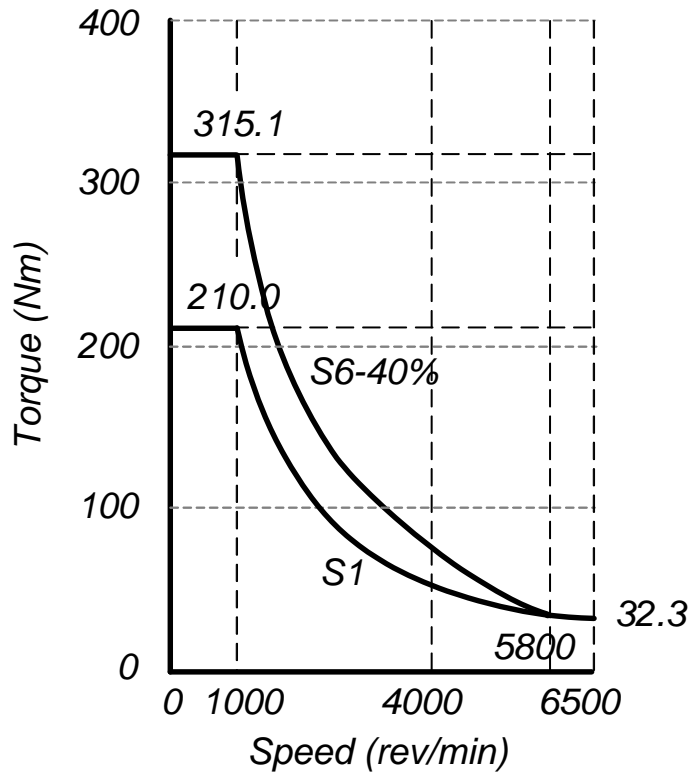

FM7/FM9

Ref.1107

F. 2/26

Power/torque-speed graph. FM7-B220-□□□□-E01.

T. 2/15 AC spindle motor FM7-B280-□□□□-E01.

FM7-B280-□□□□-E01							
Power Rated	Base speed	Rated torque	Rated current	Max. speed		Inertia	Approx. mass
				E01	---		
P _n (kW)	n _N (rpm)	M _n (N·m)	I _n (A _{rms})	n _{max} (rpm)		J (kg·cm ²)	B/P (kg)
28.0	1000	267.4	78.2	6500	---	2660	250/260

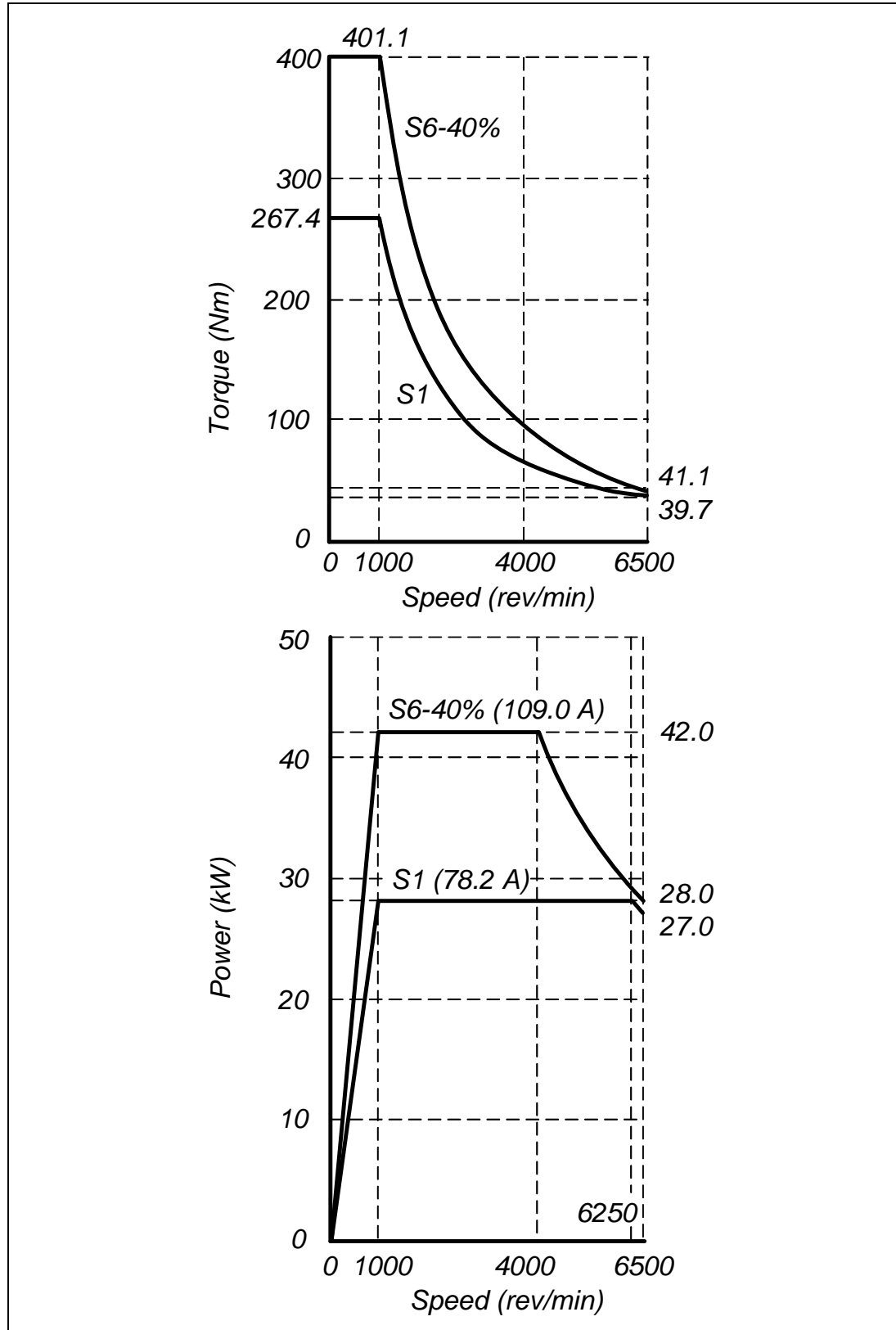

F. 2/27

Power/torque-speed graph. FM7-B280-□□□□-E01.

2.

ELECTRICAL CHARACTERISTICS
 Technical data. Power/torque-speed graphs



FM7/FM9

Ref.1107

T. 2/16 AC spindle motor FM7-C215-□□□□-E01/E02.

FM7-C215-□□□□-E01/E02							
Power Rated	Base speed	Rated torque	Rated current	Max. speed		Inertia	Approx. mass
				E01	E02		
Pn (kW)	nN (rpm)	Mn (N·m)	In (Arms)	nmax (rpm)		J (kg·cm ²)	B/P (kg)
21.5	500	410.6	87.8	5000	6000	4730	340/350

2.

ELECTRICAL CHARACTERISTICS

Technical data. Power/torque-speed graphs

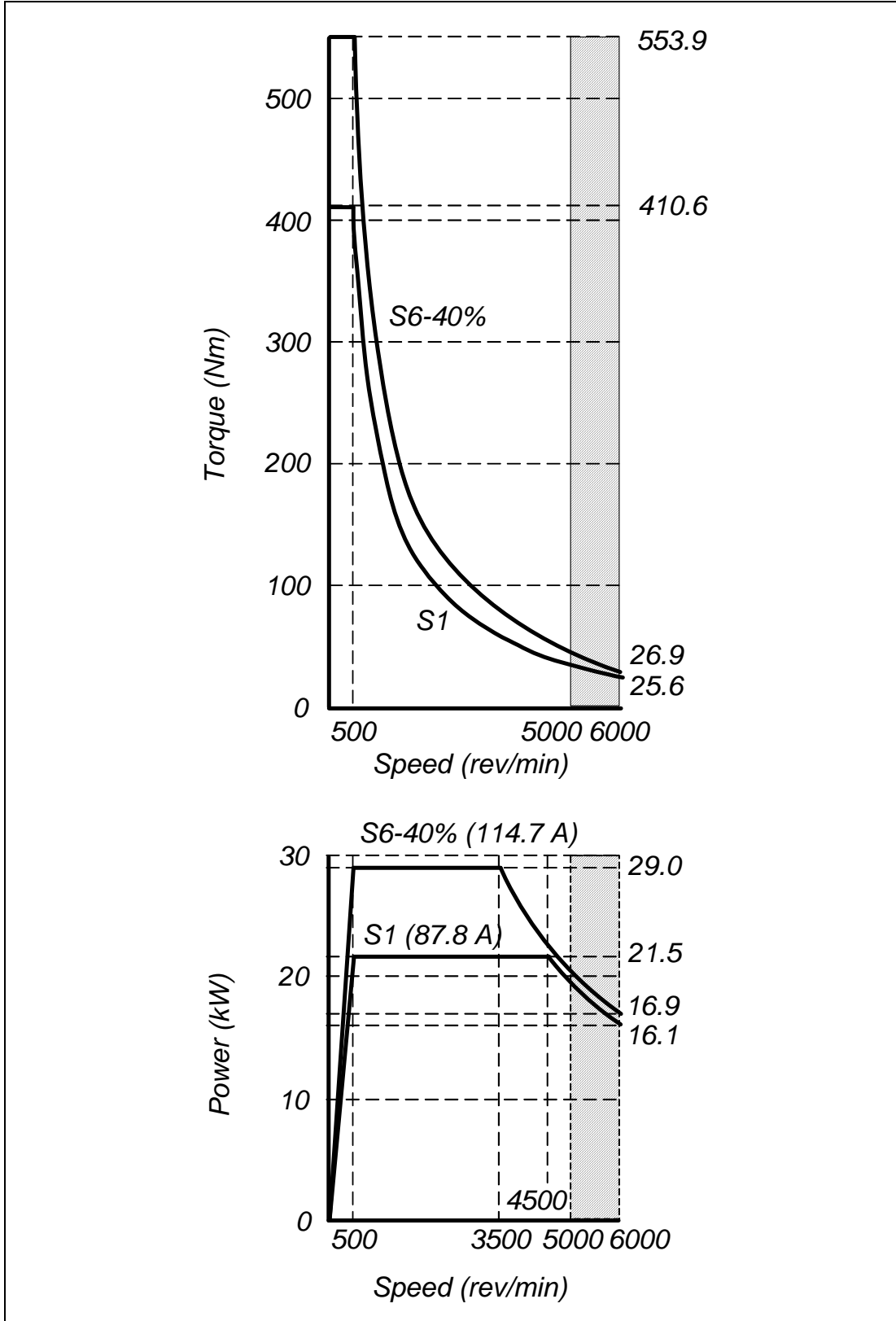

F. 2/28

Power/torque-speed graph. FM7-C215-□□□□-E01/E02.



FM7/FM9

Ref.1107

T. 2/17 AC spindle motor FM7-C270-□□□□-E01/E02.

FM7-C270-□□□□-E01/E02							
Power Rated	Base speed	Rated torque	Rated current	Max. speed		Inertia	Approx. mass
				E01	E02		
P _n (kW)	n _N (rpm)	M _n (N·m)	I _n (Arms)	n _{max} (rpm)		J (kg·cm ²)	B/P (kg)
27.0	500	515.7	116.9	5000	6000	5840	380/390

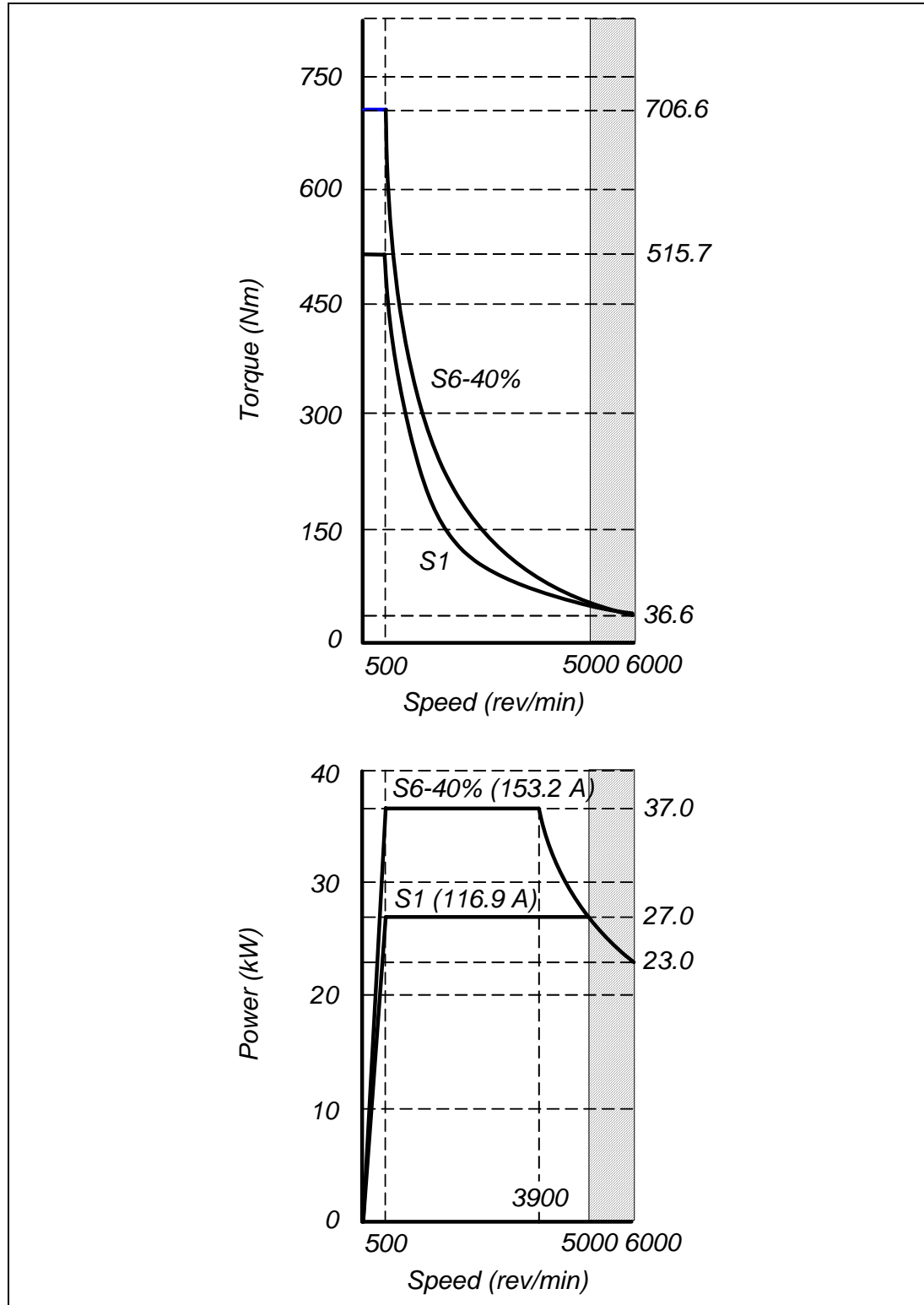

F. 2/29

Power/torque-speed graph. FM7-C270-□□□□-E01/E02.

2.

ELECTRICAL CHARACTERISTICS
 Technical data. Power/torque-speed graphs



FM7/FM9

Ref.1107

T. 2/18 AC spindle motor FM7-E600-C□B□-E01.

FM7-E600-C□B□-E01							
Power Rated	Base speed	Rated torque	Rated current	Max. speed		Inertia	Approx. mass
				E01	---		
Pn (kW)	nN (rpm)	Mn (N·m)	In (Arms)	nmax (rpm)		J (kg·cm ²)	B/P/B+P(kg)
60.0	1250	458.4	117.4	5000	---	8720	525/540/545

2.

ELECTRICAL CHARACTERISTICS

Technical data. Power/torque-speed graphs

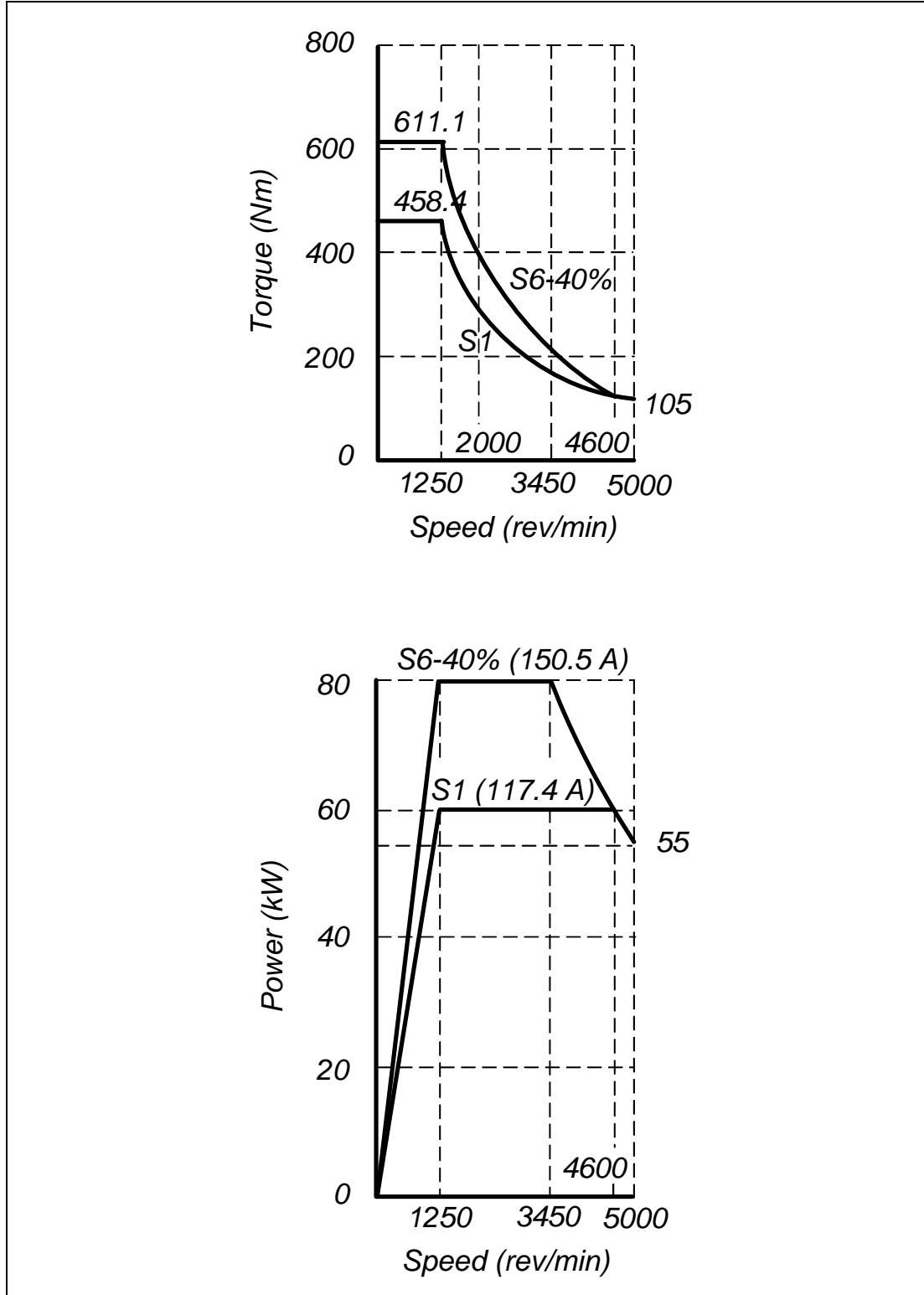

F. 2/30

Power/torque-speed graph. FM7-E600-C□B□-E01.



FM7/FM9

Ref.1107

2.5.2 FM9-XXXX-C5CX-E01 series

T. 2/19 AC spindle motor FM9-B055-C5C□-E01.

FM9-B055-C5C□-E01							
Power Rated	Base speed	Rated torque	Rated current	Max. speed		Inertia	Approx. mass
				E01	---		
P _n (kW)	n _N (rpm)	M _n (N·m)	I _n (Arms)	n _{max} (rpm)		J (kg·cm ²)	B+P (kg)
55.0	1000	525.2	104.4	5000	---	6900	440

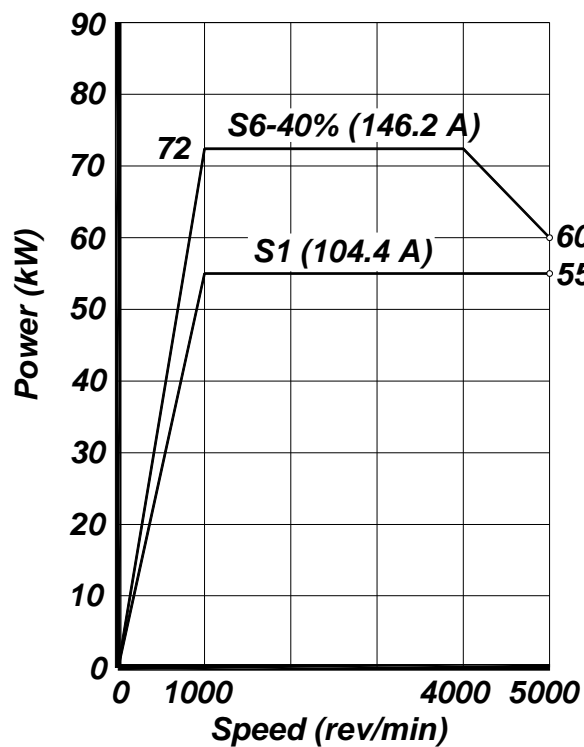
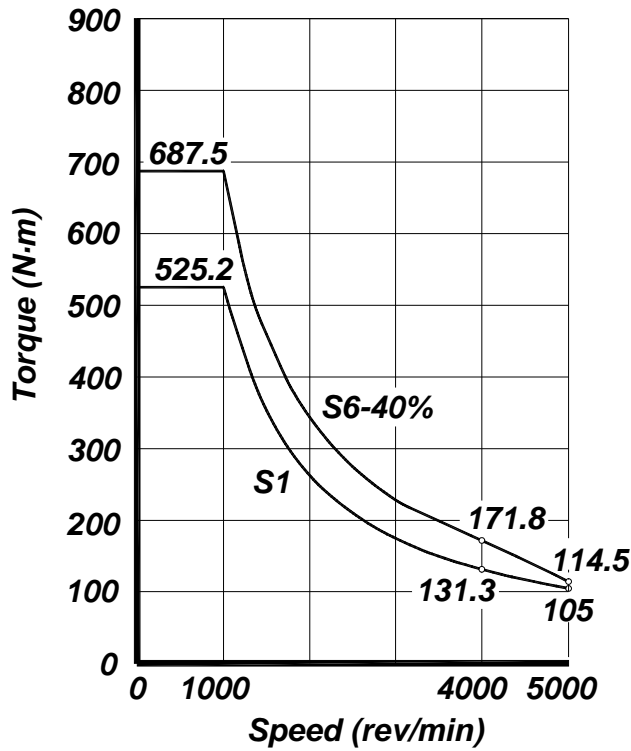

2.

ELECTRICAL CHARACTERISTICS
 Technical data. Power/torque-speed graphs



FM7/FM9

Ref.1107

F. 2/31

Power/torque-speed graph. FM9-B055-C5C□-E01.

T. 2/20 AC spindle motor FM9-B071-C5C□-E01.

FM9-B071-C5C□-E01							
Power Rated	Base speed	Rated torque	Rated current	Max. speed		Inertia	Approx. mass
				E01	---		
P _n (kW)	n _N (rpm)	M _n (N·m)	I _n (Arms)	n _{max} (rpm)		J (kg·cm ²)	B+P (kg)
71.0	1000	678	134.8	4500	---	14790	680

2.

ELECTRICAL CHARACTERISTICS
Technical data. Power/torque-speed graphs

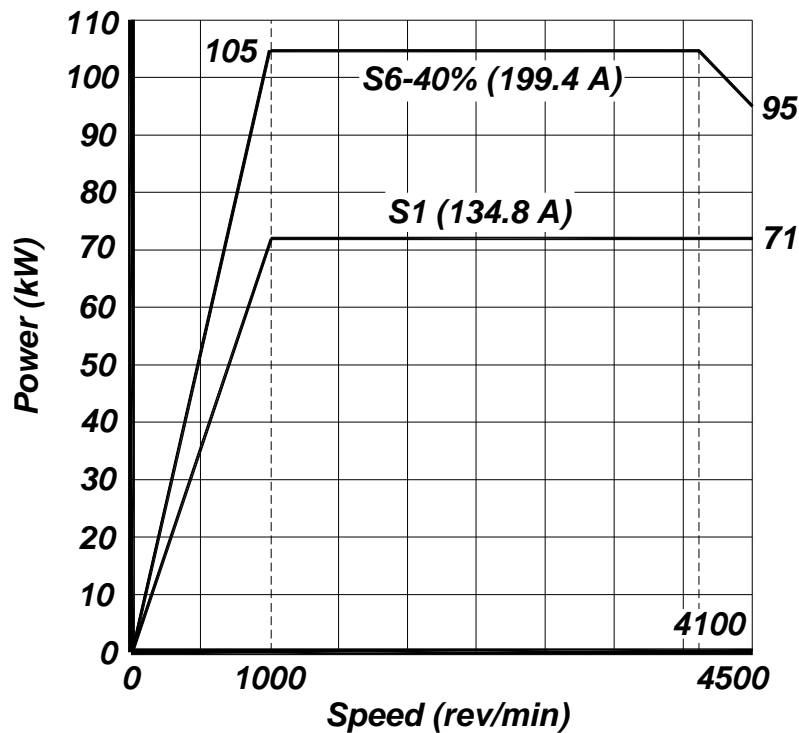
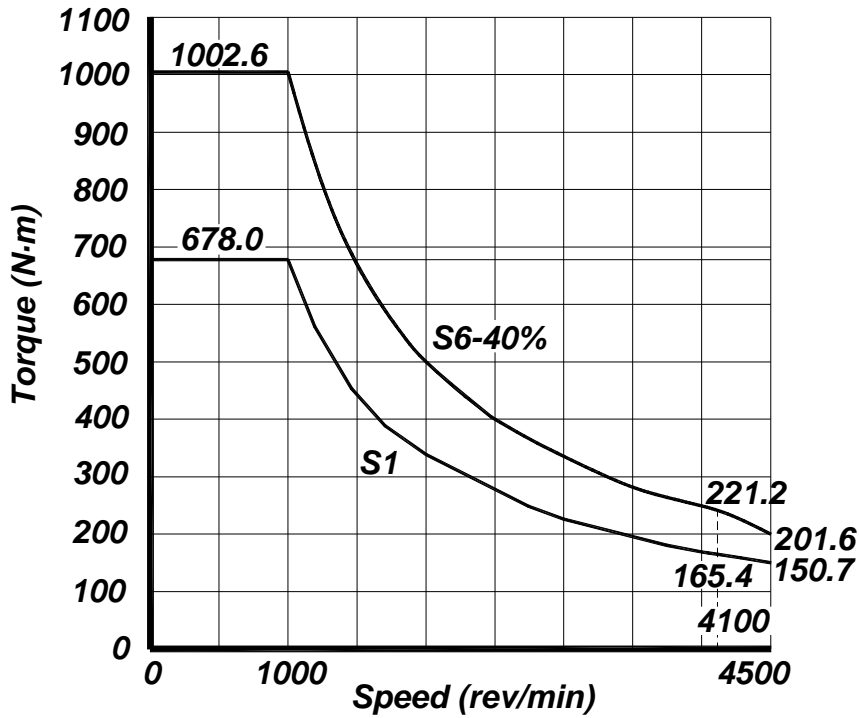

F. 2/32

Power/torque-speed graph. FM9-B071-C5C□-E01.



FM7/FM9

Ref.1107

T. 2/21 AC spindle motor FM9-A100-C5C□-E01.

FM9-A100-C5C□-E01							
Power Rated	Base speed	Rated torque	Rated current	Max. speed		Inertia	Approx. mass
				E01	---		
P _n (kW)	n _N (rpm)	M _n (N·m)	I _n (Arms)	n _{max} (rpm)		J (kg·cm ²)	B+P (kg)
100	1500	636.6	190	4500	---	14790	635

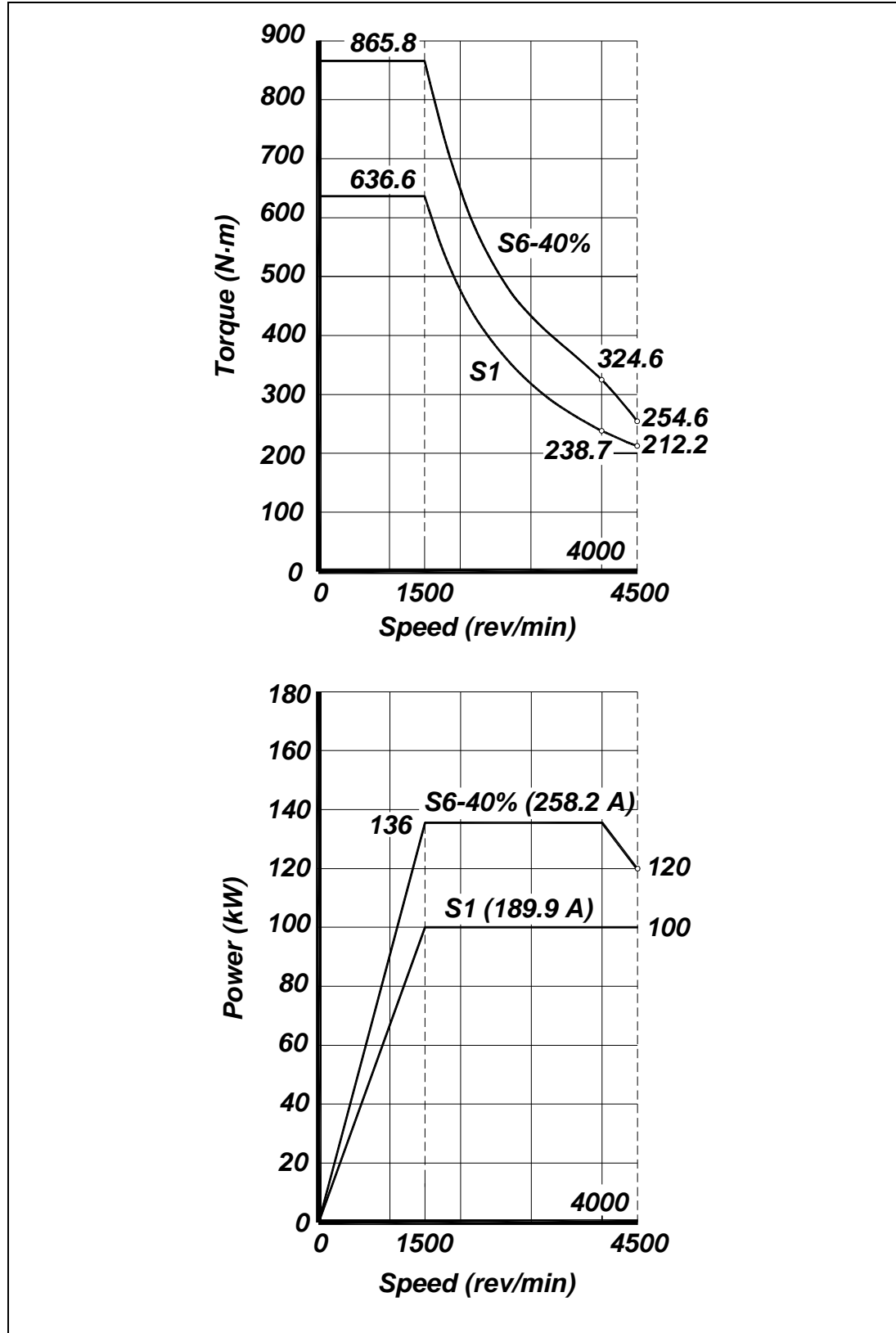

2.

ELECTRICAL CHARACTERISTICS
 Technical data. Power/torque-speed graphs



FM7/FM9

Ref.1107

F. 2/33

Power/torque-speed graph. FM9-A100-C5C□-E01.

T. 2/22 AC spindle motor FM9-B113-C5C□-E01.

FM9-B113-C5C□-E01							
Power Rated	Base speed	Rated torque	Rated current	Max. speed		Inertia	Approx. mass
				E01	---		
P _n (kW)	n _N (rpm)	M _n (N·m)	I _n (Arms)	n _{max} (rpm)		J (kg·cm ²)	B+P (kg)
113	1000	1079	215	4500	---	23260	860

2.

ELECTRICAL CHARACTERISTICS

Technical data. Power/torque-speed graphs

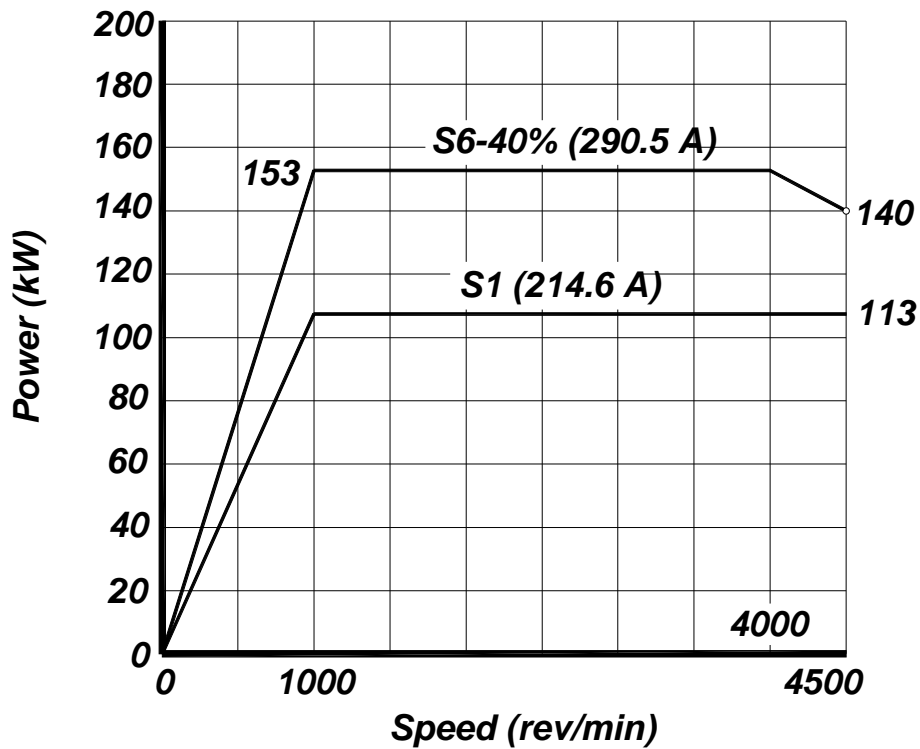
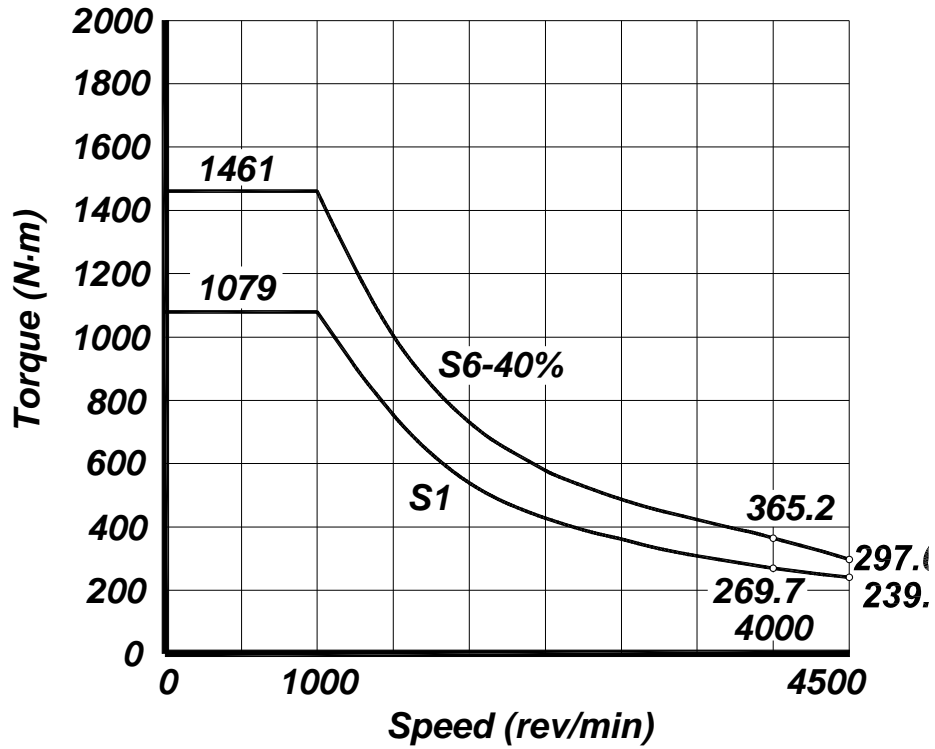

F. 2/34

Power/torque-speed graph. FM9-B113-C5C□-E01.



FM7/FM9

Ref.1107

T. 2/23 AC spindle motor FM9-A130-C5C□-E01.

FM9-A130-C5C□-E01							
Power Rated	Base speed	Rated torque	Rated current	Max. speed		Inertia	Approx. mass
				E01	---		
Pn (kW)	nN (rpm)	Mn (N·m)	In (Arms)	nmax (rpm)		J (kg·cm ²)	B+P (kg)
130	1500	827.6	246.9	4500	---	19300	745

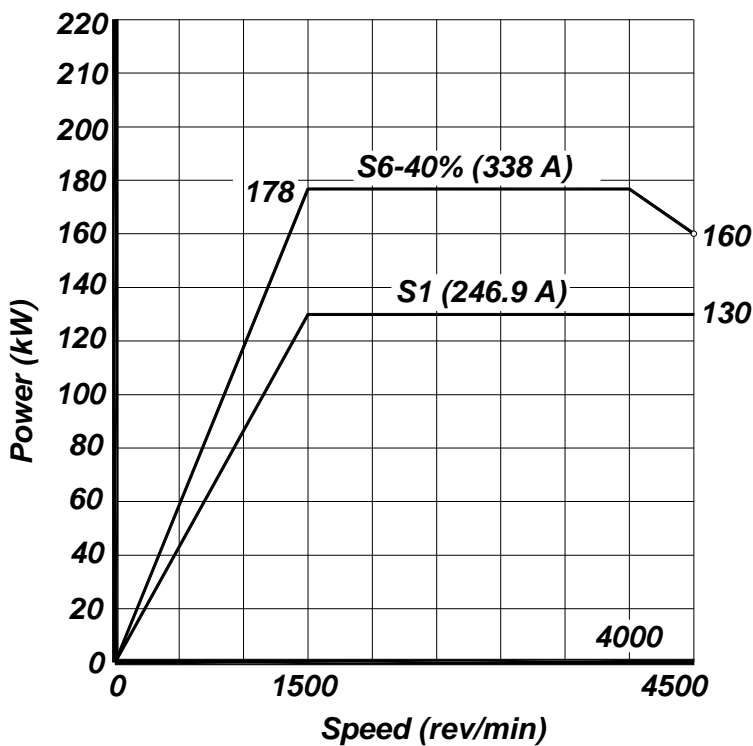
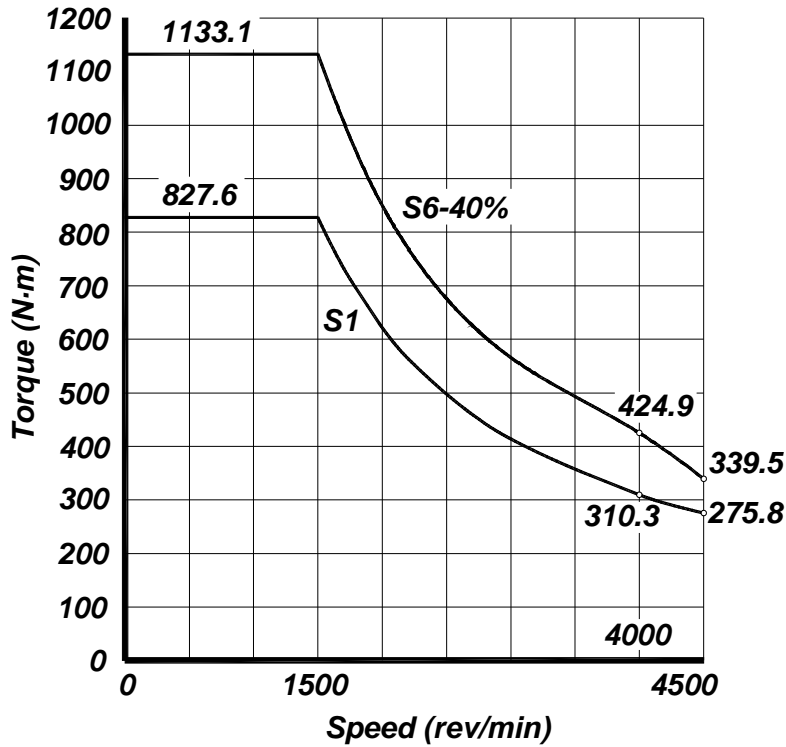

2.

ELECTRICAL CHARACTERISTICS
 Technical data. Power/torque-speed graphs



FM7/FM9

Ref.1107

2.5.3 FM7-DXXX-S1D0-E03 series

T. 2/24 AC spindle motor FM7-D055-S1D0-E03.

FM7-D055-S1D0-E03							
Type of connection	Rated power	Base speed	Rated torque	Rated current	Max. speed	Inertia	Approx. mass
	Pn (kW)	nN (rpm)	Mn (N·m)	In (Arms)	E03		
					nmax (rpm)	J (kg·cm ²)	B (kg)
▲	5.5	1500	35.0	20.3	15000	210	67
Δ	5.5	4000	13.1	20.7	15000	210	67

2.

ELECTRICAL CHARACTERISTICS
Technical data. Power/torque-speed graphs

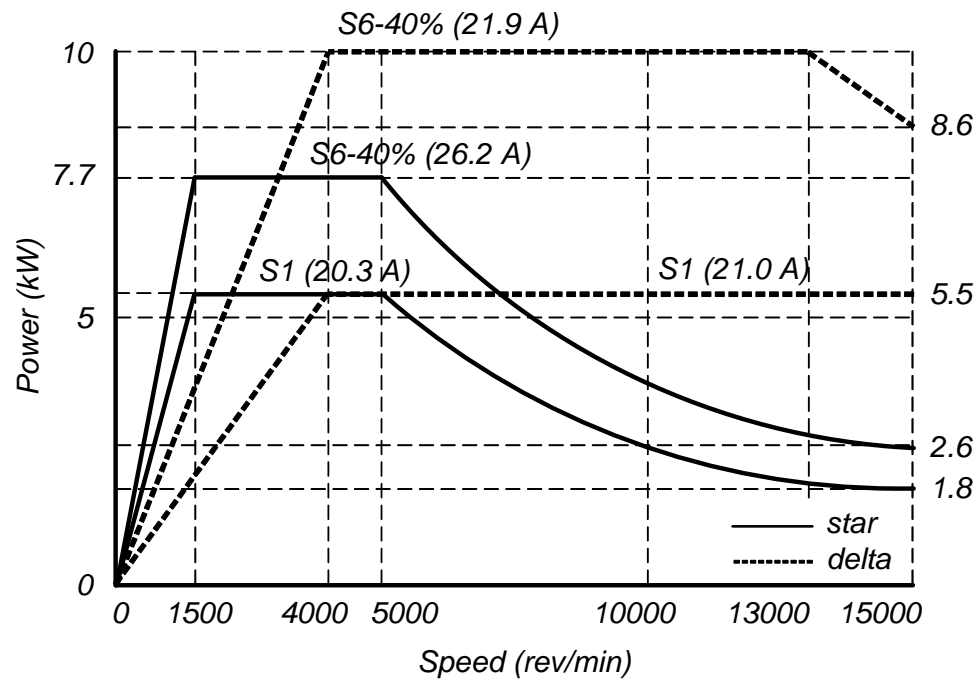
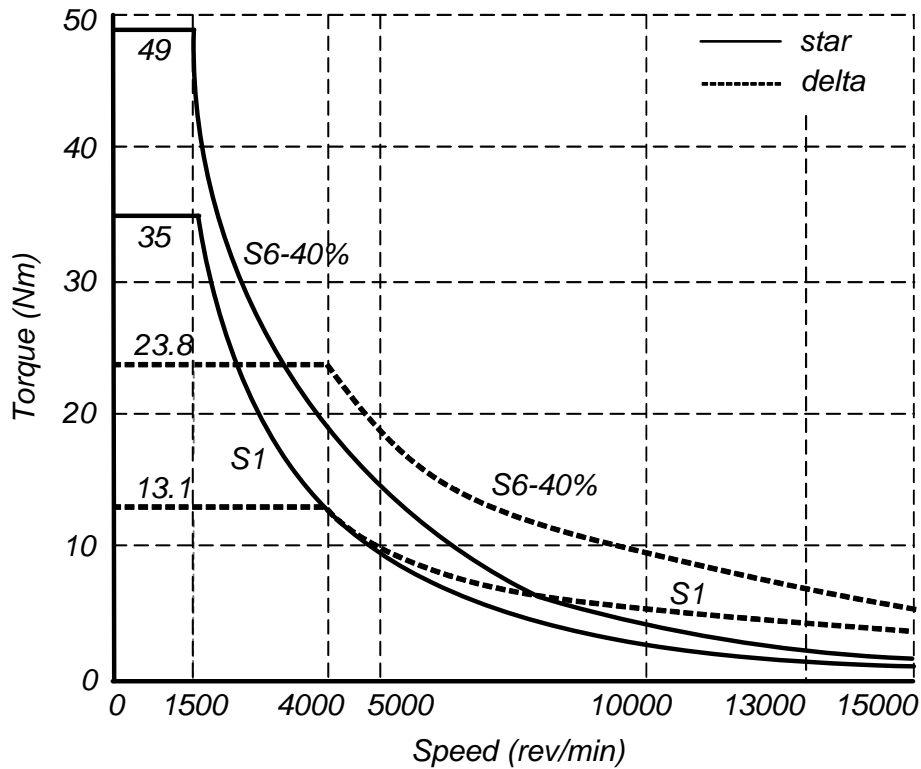

F. 2/36

Power/torque-speed graph. FM7-D055-S1D0-E03.



FM7/FM9

Ref.1107

T. 2/25 AC spindle motor FM7-D075-S1D0-E03.

FM7-D075-S1D0-E03							
Type of connection	Rated power	Base speed	Rated torque	Rated current	Max. speed	Inertia	Approx. mass
					E03		
	Pn (kW)	nN (rpm)	Mn (N·m)	In (Arms)	nmax. (rpm)	J (kg·cm ²)	B (kg)
▲	7.5	1500	47.7	26.5	15000	260	74
Δ	7.5	4000	17.9	25.8	15000	260	74

2.

ELECTRICAL CHARACTERISTICS
 Technical data. Power/torque-speed graphs

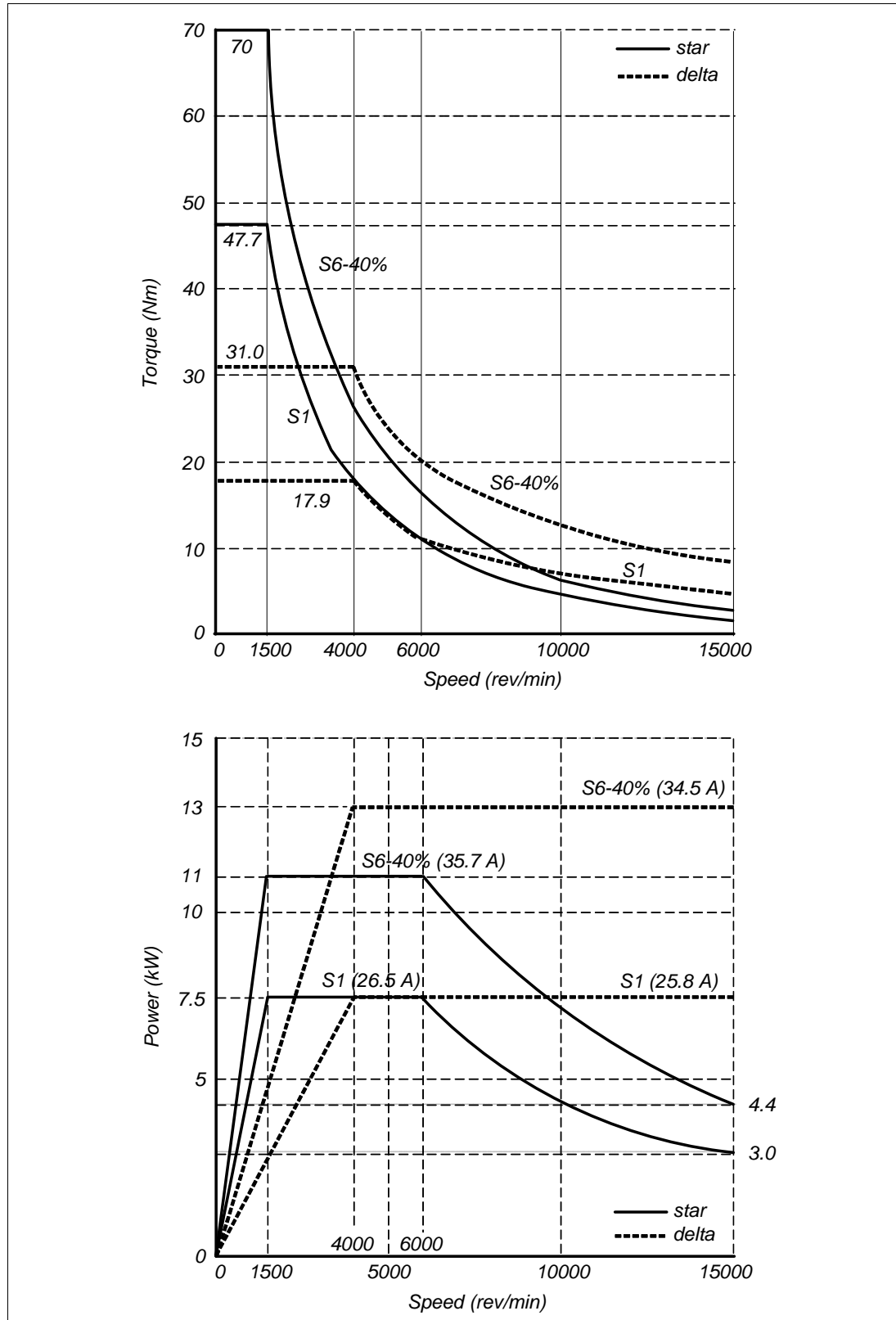

F. 2/37

Power/torque-speed graph. FM7-D075-S1D0-E03.



FM7/FM9

Ref.1107

T. 2/26 AC spindle motor FM7-D110-S1D0-E03.

FM7-D110-S1D0-E03							
Type of connection	Rated power	Base speed	Rated torque	Rated current	Max. speed	Inertia	Approx. mass
					E03		
	Pn (kW)	nN (rpm)	Mn (N·m)	In (Arms)	nmax. (rpm)	J (kg·cm ²)	B (kg)
▲	11.0	1500	70.0	38.0	12000	690	110
Δ	11.0	4000	26.3	40.0	12000	690	110

2.

ELECTRICAL CHARACTERISTICS
 Technical data. Power/torque-speed graphs

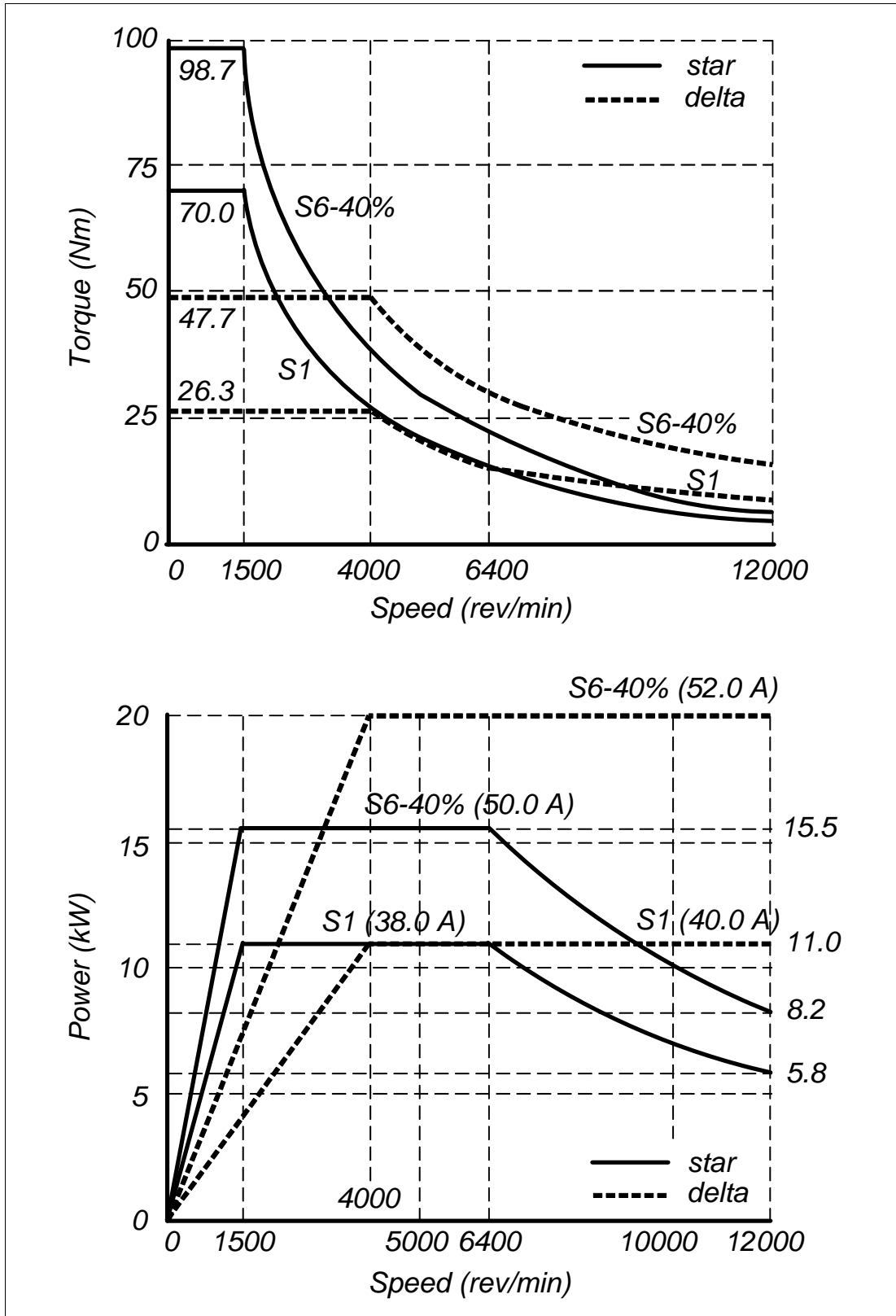

F. 2/38

Power/torque-speed graph. FM7-D110-S1D0-E03.



FM7/FM9

Ref.1107

T. 2/27 AC spindle motor FM7-D150-S1D0-E03.

FM7-D150-S1D0-E03							
Type of connection	Rated power	Base speed	Rated torque	Rated current	Max. speed	Inertia	Approx. mass
					E03		
	Pn (kW)	nN (rpm)	Mn (N·m)	In (Arms)	nmax. (rpm)	J (kg·cm ²)	B (kg)
▲	15.0	1500	95.5	46.4	12000	690	110
Δ	15.0	4000	35.8	45.7	12000	690	110

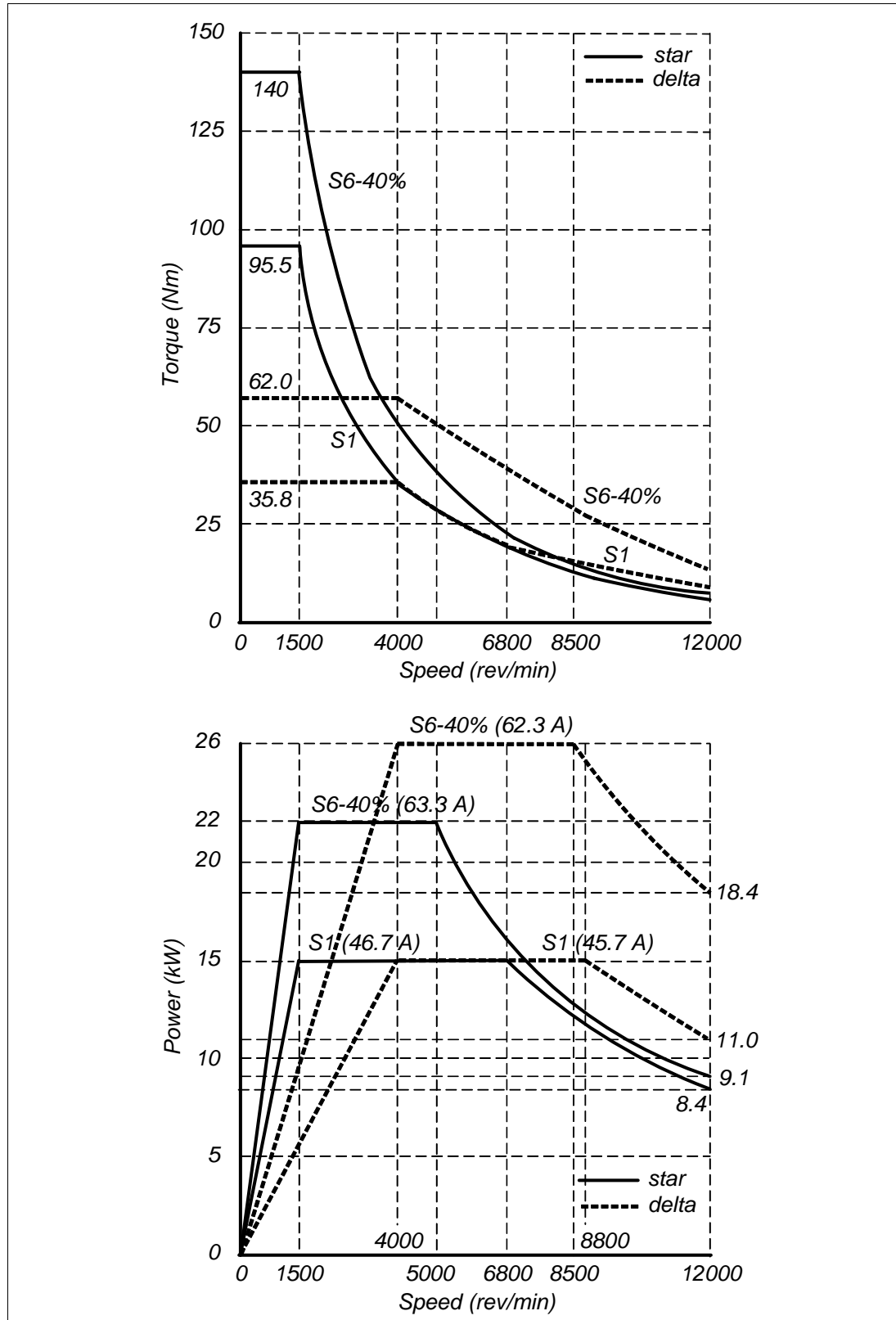

F. 2/39

Power/torque-speed graph. FM7-D150-S1D0-E03.

2.

ELECTRICAL CHARACTERISTICS
 Technical data. Power/torque-speed graphs



FM7/FM9

Ref.1107

T. 2/28 AC spindle motor FM7-D185-S1D0-E03.

FM7-D185-S1D0-E03							
Type of connection	Rated power	Base speed	Rated torque	Rated current	Max. speed	Inertia	Approx. mass
					E03		
	Pn (kW)	nN (rpm)	Mn (N·m)	In (Arms)	nmax. (rpm)	J (kg·cm ²)	B (kg)
▲	18.5	1500	117.8	49.2	12000	890	135
△	18.5	4000	44.2	49.2	12000	890	135

2.

ELECTRICAL CHARACTERISTICS

Technical data. Power/torque-speed graphs

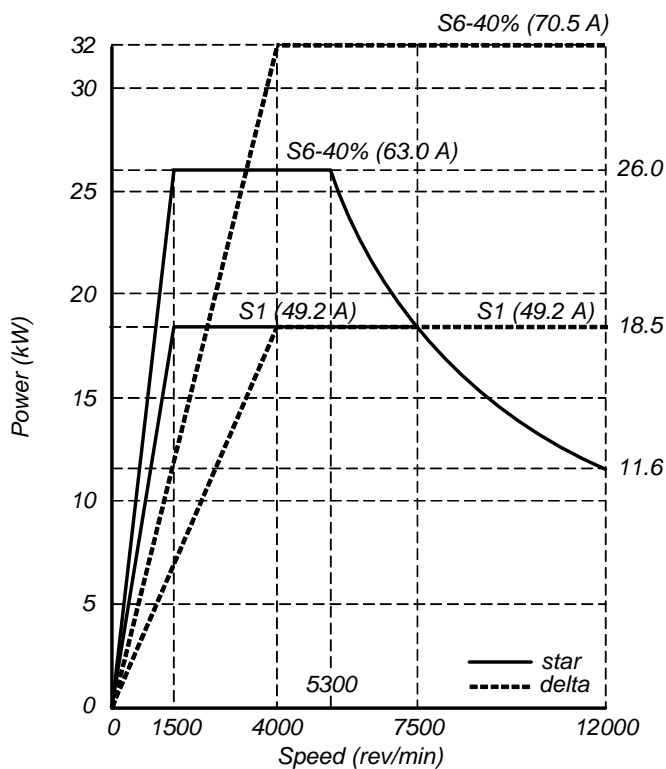
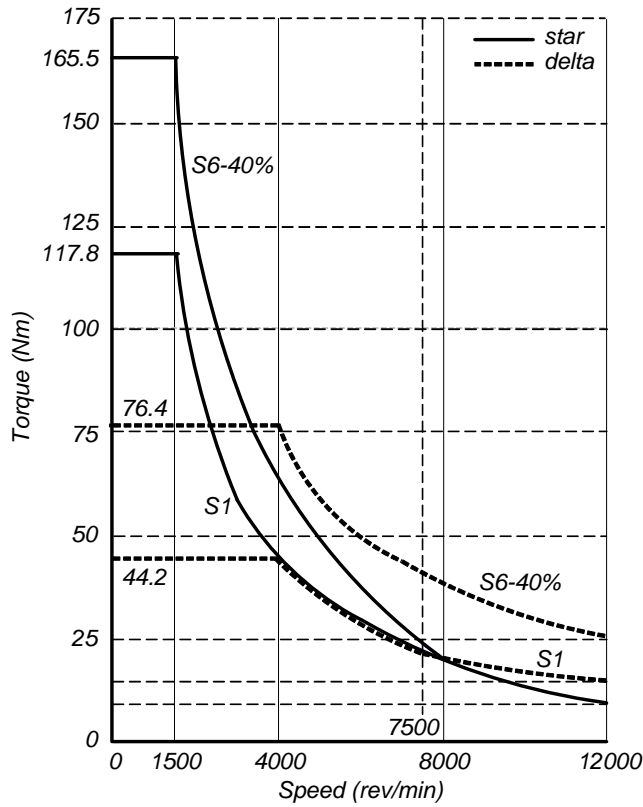

F. 2/40

Power/torque-speed graph. FM7-D185-S1D0-E03.



FM7/FM9

Ref.1107

T. 2/29 AC spindle motor FM7-D220-S1D0-E03.

FM7-D220-S1D0-E03							
Type of connection	Rated power	Base speed	Rated torque	Rated current	Max. speed	Inertia	Approx. mass
	Pn (kW)	nN (rpm)	Mn (N·m)	In (Arms)	E03 nmax. (rpm)		
▲	22.0	1500	140.1	62.3	12000	1080	150
Δ	22.0	4000	52.2	61.7	12000	1080	150

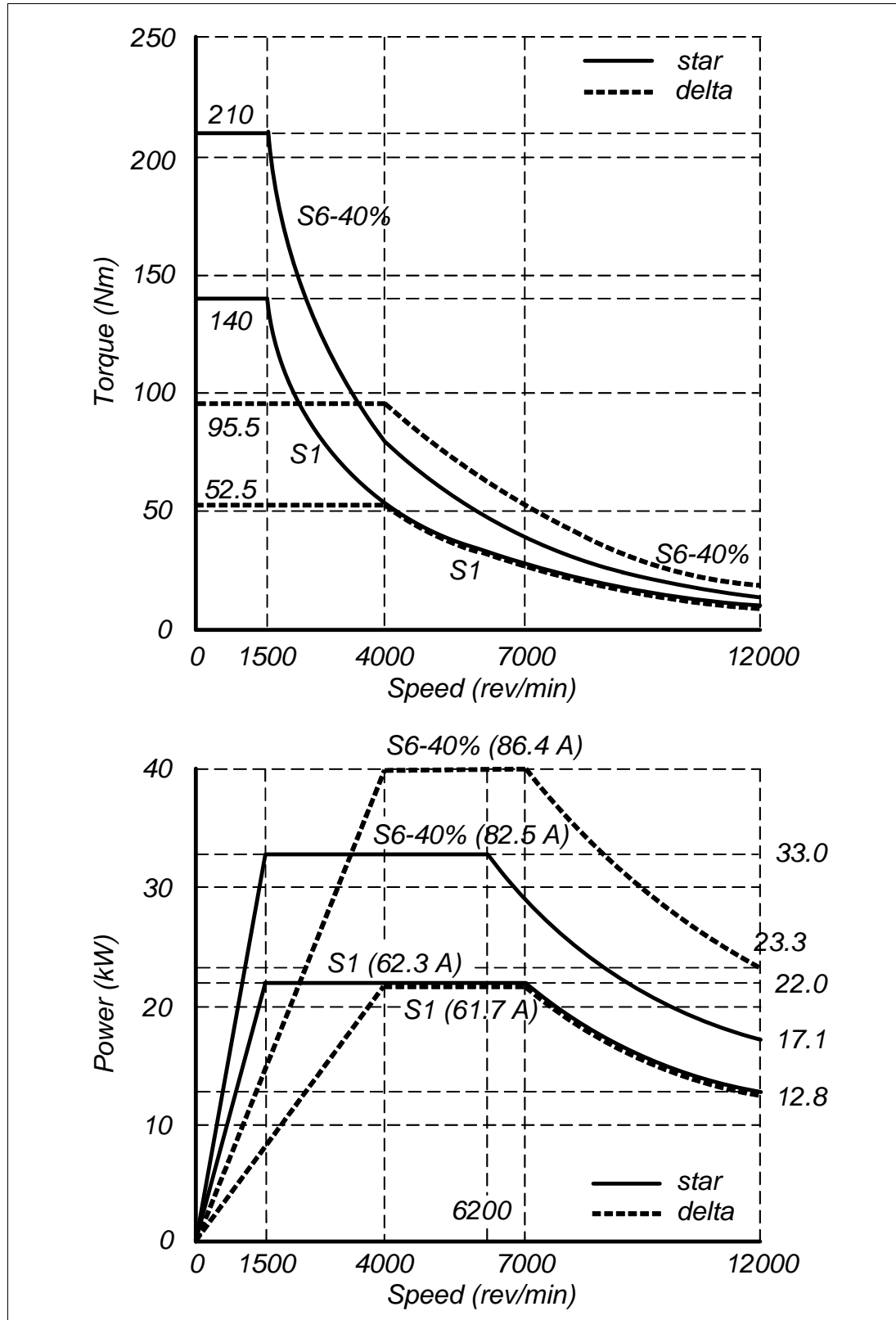

F. 2/41

Power/torque-speed graph. FM7-D220-S1D0-E03.

2.

ELECTRICAL CHARACTERISTICS
Technical data. Power/torque-speed graphs



FM7/FM9

Ref.1107

2.5.4 FM7-DXXX-S1D0-HS3 series

T. 2/30 AC spindle motor FM7-D075-S1D0-HS3.

FM7-D075-S1D0-HS3							
Type of connection	Rated power	Base speed	Rated torque	Rated current	Max. speed	Inertia	Approx. mass
	Pn (kW)	nN (rpm)	Mn (N·m)	In (Arms)	HS3		
	▲	7.5	1500	47.7	26.5	nmax (rpm)	J (kg·cm ²)
Δ	7.5	4000	17.9	25.8	15000	260	77

2.

ELECTRICAL CHARACTERISTICS
Technical data. Power/torque-speed graphs

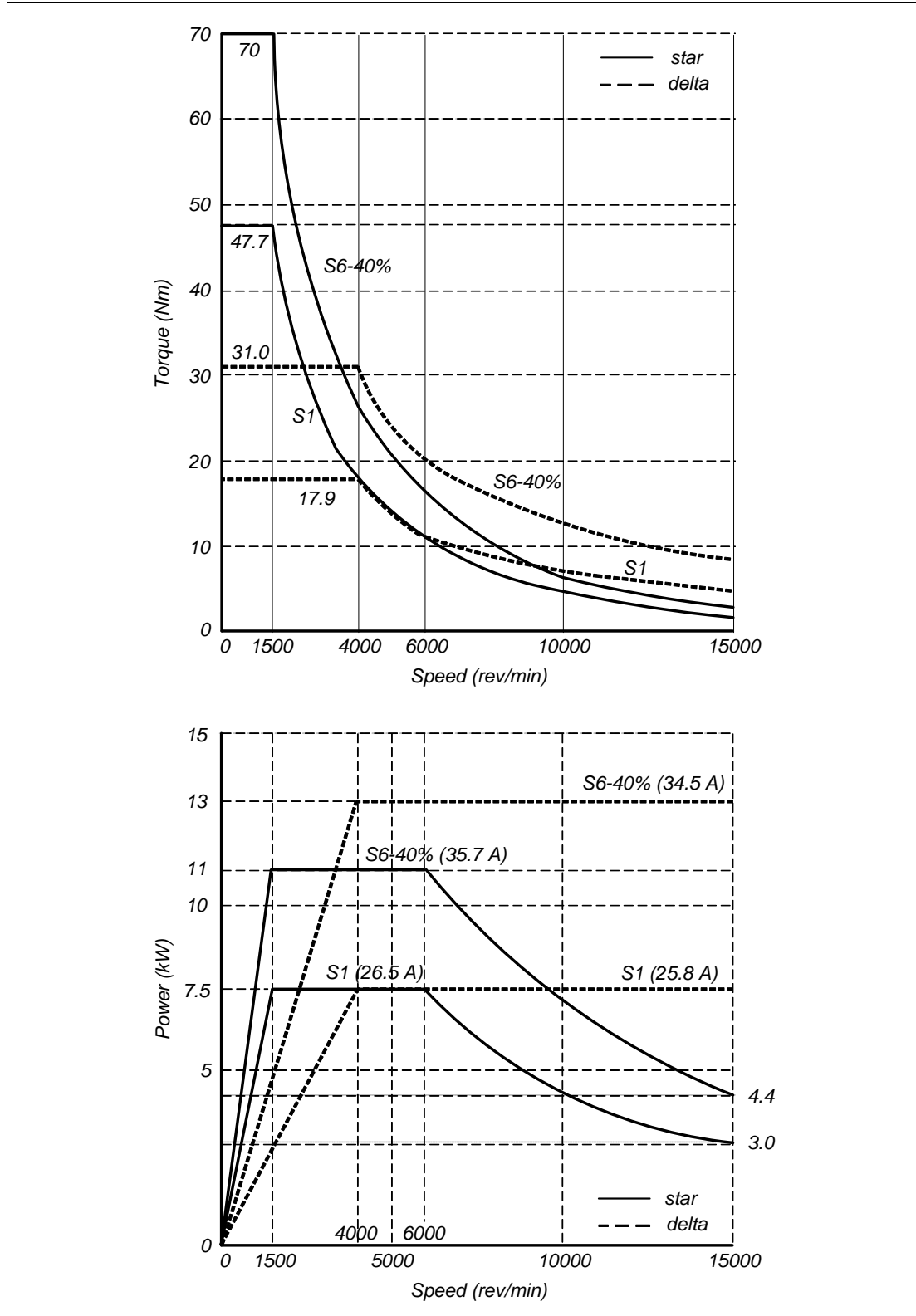

F. 2/42

Power/torque-speed graph. FM7-D075-S1D0-HS3.



FM7/FM9

Ref.1107

T. 2/31 AC spindle motor FM7-D110-S1D0-HS3.

FM7-D110-S1D0-HS3							
Type of connection	Rated power	Base speed	Rated torque	Rated current	Max. speed	Inertia	Approx. mass
	Pn (kW)	nN (rpm)	Mn (N·m)	In (Arms)	HS3		
					nmax (rpm)	J (kg·cm ²)	B (kg)
▲	11.0	1500	70.0	38.0	12000	690	115
Δ	11.0	4000	26.3	40.0	12000	690	115

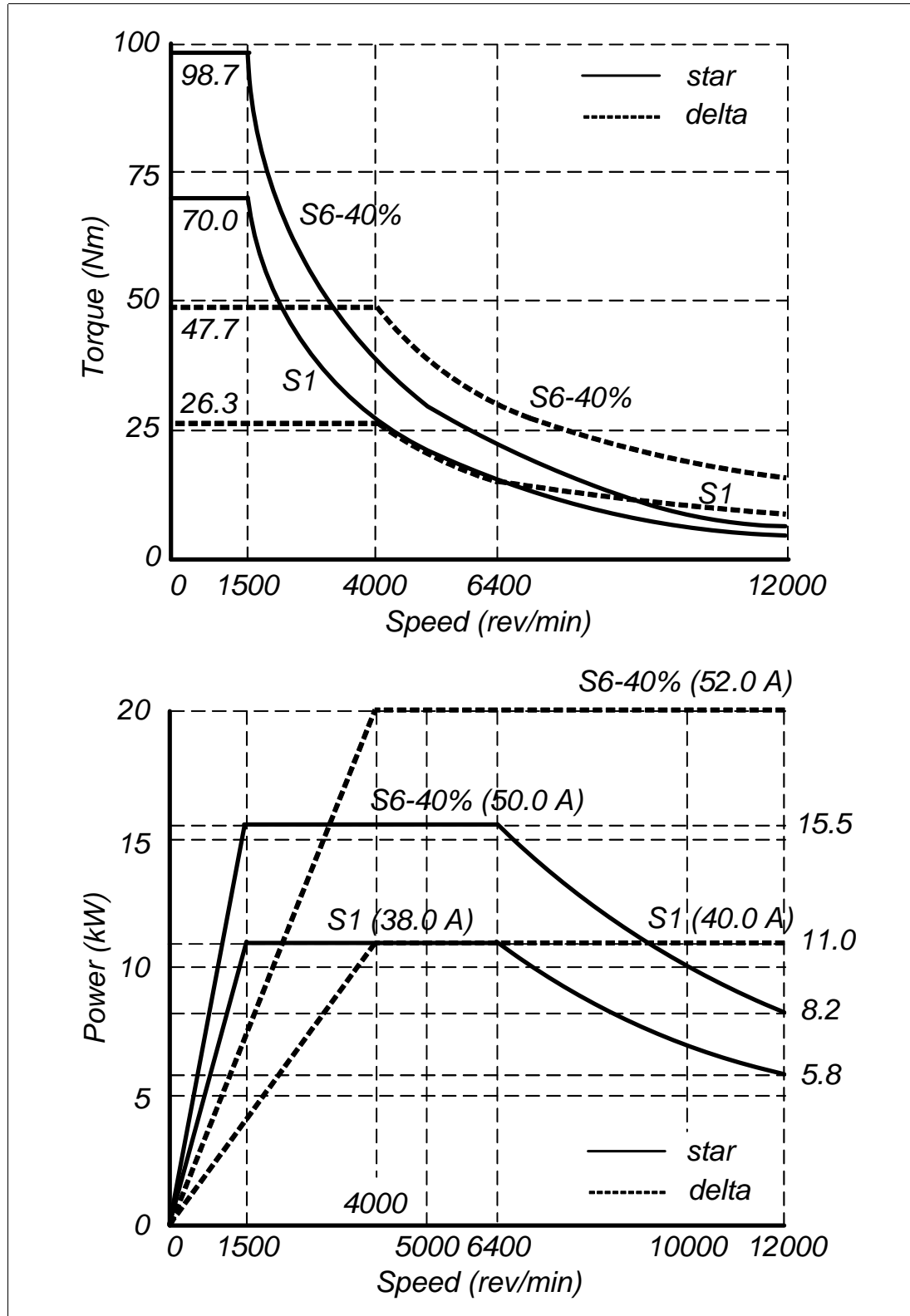

F. 2/43

Power/torque-speed graph. FM7-D110-S1D0-HS3.

2.

ELECTRICAL CHARACTERISTICS
 Technical data. Power/torque-speed graphs



FM7/FM9

Ref.1107

T. 2/32 AC spindle motor FM7-D185-S1D0-HS3.

FM7-D185-S1D0-HS3							
Type of connection	Rated power	Base speed	Rated torque	Rated current	Max. speed	Inertia	Approx. mass
					HS3		
	Pn (kW)	nN (rpm)	Mn (N·m)	In (Arms)	nmax (rpm)	J (kg·cm ²)	B (kg)
▲	18.5	1500	117.8	49.2	12000	890	140
Δ	18.5	4000	44.2	49.2	12000	890	140

2.

ELECTRICAL CHARACTERISTICS
 Technical data. Power/torque-speed graphs

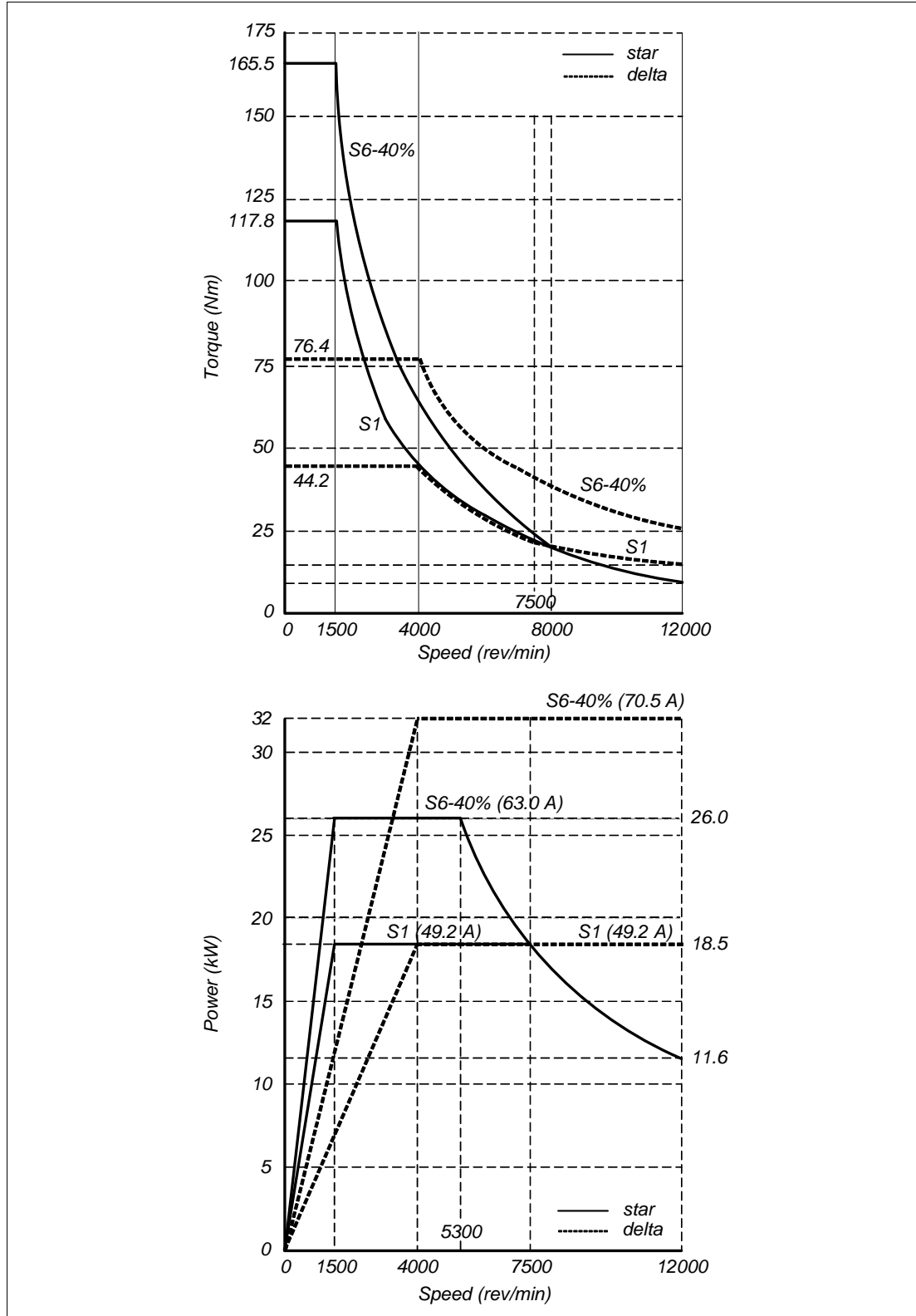

F. 2/44

Power/torque-speed graph. FM7-D185-S1D0-HS3.



FM7/FM9

Ref.1107

T. 2/33 AC spindle motor FM7-D220-S1D0-HS3.

FM7-D220-S1D0-HS3							
Type of connection	Rated power	Base speed	Rated torque	Rated current	Max. speed	Inertia	Approx. mass
	Pn (kW)	nN (rpm)	Mn (N·m)	In (Arms)	HS3		
					nmax (rpm)	J (kg·cm ²)	B (kg)
▲	22.0	1500	140.1	62.3	12000	1080	155
Δ	22.0	4000	52.2	61.7	12000	1080	155

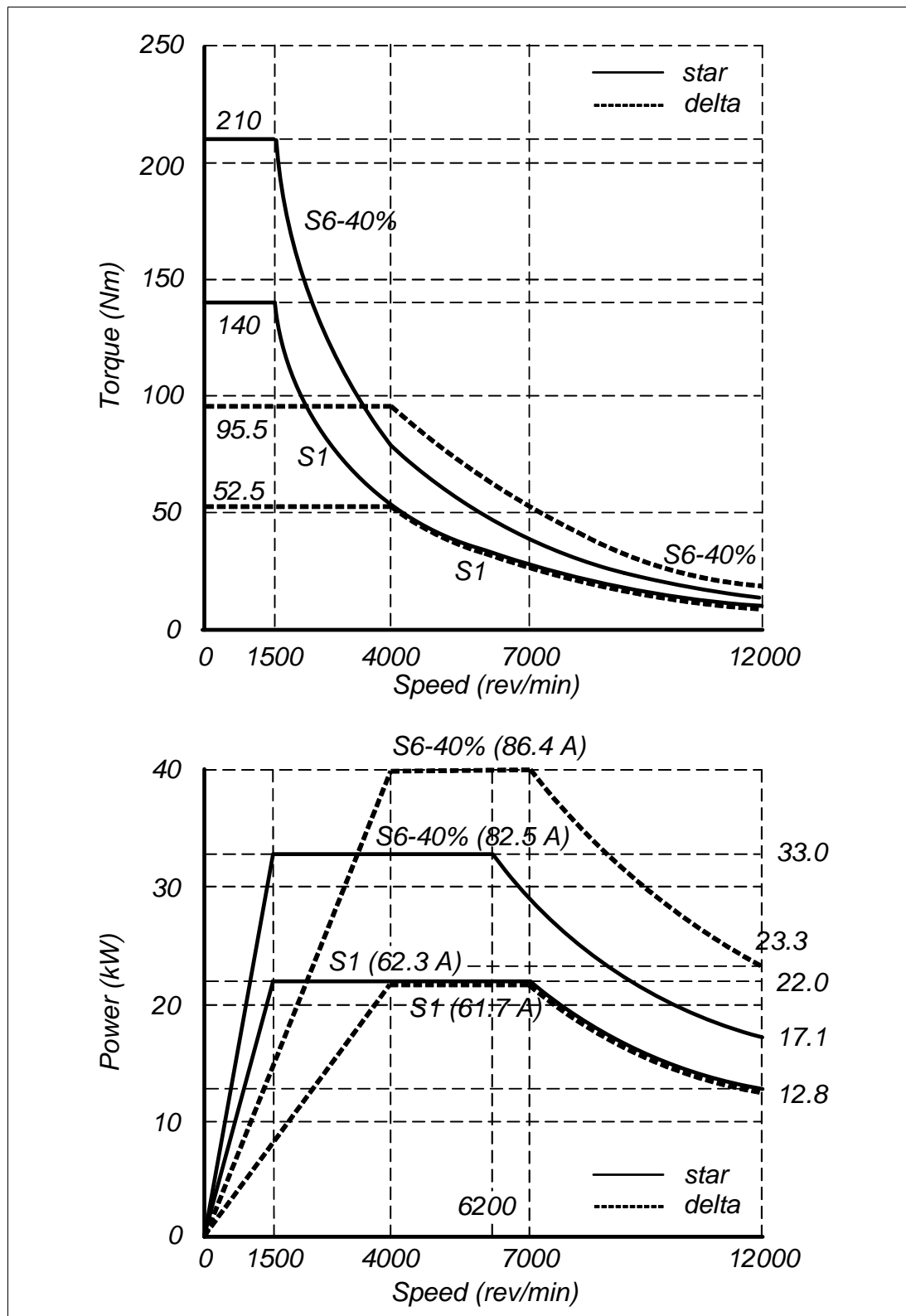

F. 2/45

Power/torque-speed graph. FM7-D220-S1D0-HS3.

2.

ELECTRICAL CHARACTERISTICS

Technical data. Power/torque-speed graphs



FM7/FM9

Ref.1107

2.

ELECTRICAL CHARACTERISTICS



A large grid for drawing or calculation, with a pencil icon in the top right corner.



FM7/FM9

Ref.1107

MECHANICAL CHARACTERISTICS

3

3.1 Built

On FM7 motor models

The following figure shows the mounting possibilities for these AC spindle motors:

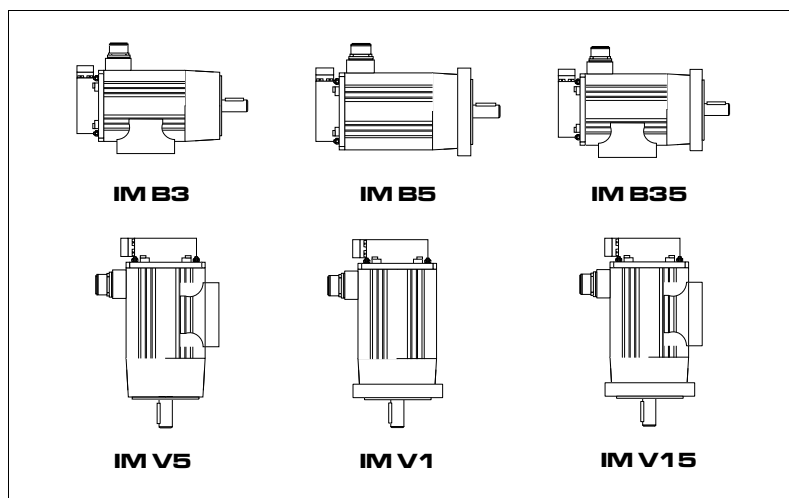

F. 3/1

FM7 motor mounting methods.

where the meaning of this nomenclature according to IEC 60034-7 is:

Code. I	Code. II	Built
IM B3	IM 1001	Foot mounting, horizontal shaft.
IM B5	IM 3001	Flange mounting, horizontal shaft.
IM V1	IM 3011	Flange mounting, vertical shaft facing down.
IM V5	IM 1011	Foot mounting, vertical shaft facing down.
IM B35	IM 2001	Foot & flange mount. Large flange with through holes. Horizontal shaft.
IM V15	IM 2011	Foot & flange mount. Large flange with through holes. Vertical shaft facing down.

The possibilities for these motor series are:

FM7-□□□□-□□□□-E01	IM B3, IM B5, IM B35, IM V1, IM V5, IM V15
FM7-□□□□-□□□□-E02	IM B3, IM B5, IM B35, IM V1, IM V5, IM V15
FM7-D□□□-S1D0-E03	IM B5, IM V1
FM7-D□□□-S1D0-HS3	IM B5, IM V1



WARNING. Make sure you don't mount an asynchronous spindle motor of the FM7 family (no matter the series or the model) with its shaft facing up.

FAGOR 

FM7/FM9

Ref.1107

3.

MECHANICAL CHARACTERISTICS
Built

On FM9 motor models

The following figure shows the mounting possibilities for these AC spindle motors:

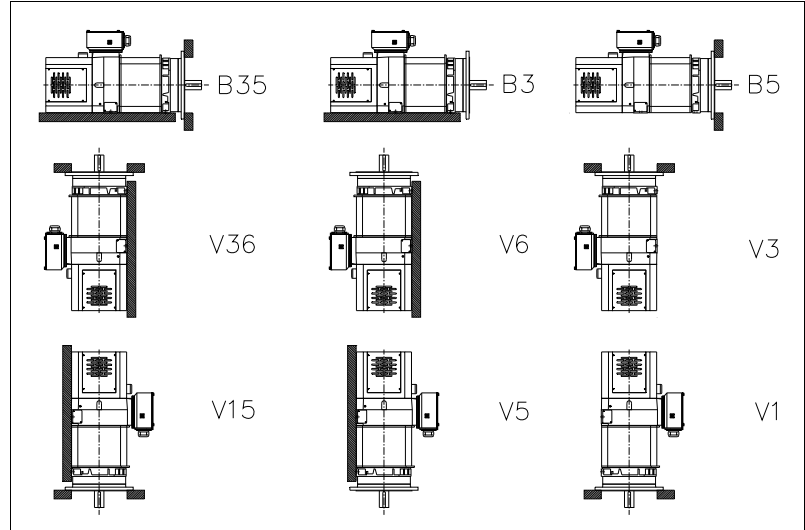

F. 3/2

FM9 motor mounting methods.

where the meaning of this nomenclature according to IEC 60034-7 is:

Code. I	Code. II	Built
IM B3	IM 1001	Foot mounting, horizontal shaft.
IM B5	IM 3001	Flange mounting, horizontal shaft.
IM V1	IM 3011	Flange mounting, vertical shaft facing down.
IM V5	IM 1011	Foot mounting, vertical shaft facing down.
IM V3	IM 3031	Flange mounting, vertical shaft facing up.
IM V6	IM 1031	Foot mounting, vertical shaft facing up.
IM B35	IM 2001	Foot & flange mount. Large flange with through holes. Horizontal shaft.
IM V15	IM 2011	Foot & flange mount. Large flange with through holes. Vertical shaft facing down.
IM V36	IM 2031	Foot & flange mount. Large flange with through holes. Vertical shaft facing up.



FM7/FM9

Ref.1107

3.2 Level of vibration

It is not possible to apply a high radial load value (perpendicular) to the motor shaft and obtain high speed and optimum vibration levels. This limitation is because the two properties require different designs of bearings and they conflict with each other.

Hence, the following graphs show the vibration limits for the available standard balancing degrees.

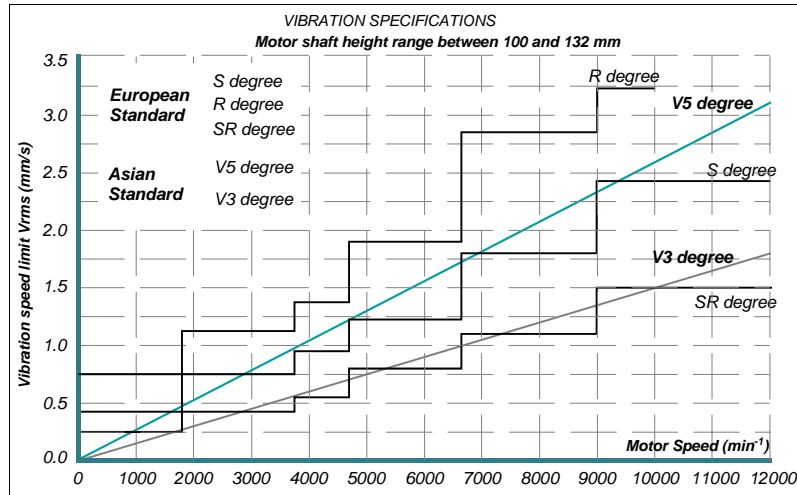

F. 3/3

Limit values of vibration levels on motors with shaft heights between 110 mm and 132 mm.

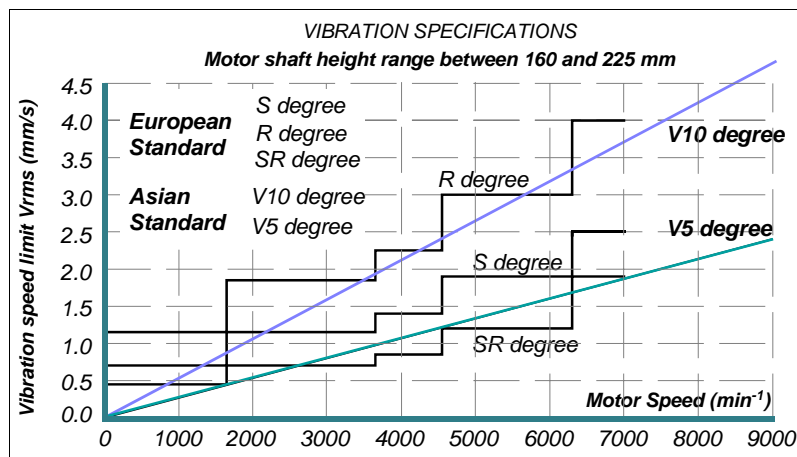

F. 3/4

Limit values of vibration levels on motors with shaft heights between 160 mm and 225 mm.

The following table shows the degrees of vibration for each motor model within its corresponding series.

Observe that either one or the other of the previous graphs must be considered depending on the shaft height of the motor being considered.

3.
MECHANICAL CHARACTERISTICS
Level of vibration



FM7/FM9

Ref.1107

3.

MECHANICAL CHARACTERISTICS
Level of vibration

Hence:

T. 3/1 Degrees of vibration.

Series FM7-D□□□-S1D0-E03		
Model	Standard	Optional
FM7-D□□□-S1D0-E03	V3	-----

Series FM7-□□□□-□□□□-E01/E02		
Model	Standard	Optional
FM7-A037-□□□□-E01/E02	V5	V3
FM7-A055-□□□□-E01/E02	V5	V3
FM7-A075-□□□□-E01/E02	V5	V3
FM7-A090-□□□□-E01/E02	V5	V3
FM7-A110-□□□□-E01/E02	V5	V3
FM7-A150-□□□□-E01/E02	V5	V3
FM7-A185-□□□□-E01/E02	V5	V3
FM7-A220-□□□□-E01/E02	V5	V3
FM7-A300-□□□□-E01	V10	V5
FM7-A370-□□□□-E01	V10	V5
FM7-A510-□□□□-E01/E02	V10	V5
FM7-B120-□□□□-E01/E02	V5	V3
FM7-B170-□□□□-E01/E02	V5	V3
FM7-B220-□□□□-E01	V10	V5
FM7-B280-□□□□-E01	V10	V5
FM7-C215-□□□□-E01/E02	V10	V5
FM7-C270-□□□□-E01/E02	V10	V5
FM7-E600-C□B□-E01	V10	---

FM9-□□□□-□-E01 series		
Model	Standard	
FM9-A□□□-C5C□-E01	V5	
FM9-B□□□-C5C□-E01	V5	

Series FM7-D□□□-S1D0-HS3		
Model	Standard	Optional
FM7-D□□□-S1D0-HS3	V3	-----

Remember that the shaft height of a motor "with flange" (without feet) or of any vertical motor, will be considered equal to the shaft height of a motor with the same base armature, but of the foot-mount type with horizontal shaft.

See the dimensions drawing of the corresponding motor model in the section: Dimensions, of this chapter, to obtain the shaft height. This value is given by the "c" dimension.



FM7/FM9

Ref.1107

3.3 Balancing

For motors with:

- Maximum speed $n_{max} < 8000$ rpm, we recommend the shaft to have a keyway and to be balanced halfkey.

When performing the half-key balancing, a rectangular full-length, half height keyway as well as a full height, half length keyway are acceptable. The keyway will be centered along the shaft regardless of the option being considered.

- Maximum speed $n_{max} \geq 8000$ rpm the shaft should be cylindrical, i.e. keyless and the balancing must be performed in these conditions.

3.**MECHANICAL CHARACTERISTICS**
Balancing**FAGOR** **FM7/FM9****Ref.1107**

3.4 Bearings

3.

MECHANICAL CHARACTERISTICS
Bearings

The useful life of the bearings will be approximately 12000 hours of continuous running and at maximum speed for all the models of FM7 spindle motors and 5000 hours for FM9 motors.

The references of the bearings located at the shaft end and at the fan end are indicated on the identifications plate stuck on one side of the motor.

For further detail, see section: Characteristics plate of chapter 6. Selection in this manual.

When starting the motor up for the first time, run it first trying to:

- Gradually increase the speed of the motor from 0 to 70 % of the maximum speed in about 20 minutes.
- Do not run the motor for too long at its maximum speed.
- Watch the temperature values and possible unusual noises.
- It may make too much noise at first, in the few initial minutes because the bearings are not evenly lubricated. At the end of this initial running, it will go back to normal.

NOTE. It is not necessary to lubricate the bearings during the whole period of the useful life of the bearing indicated earlier. These motors do not have a lubrication system.



WARNING. Blows will affect negatively the performance of the motor, hence reducing the useful life of the bearings. Do not strike any part off the motor, especially the extension of the shaft.

3.5 Radial loads

A poor alignment between the motor shaft and the machine axis increases vibration of the shaft and reduces the useful life of bearings and couplings. Likewise, exceeding certain maximum radial load values on the bearings has a similar effect.

In order to avoid these incidences, do not exceed the permitted radial load values given in the following table considering that these loads are applied at the end of the shaft extension and **for a maximum turning speed of the motor.**

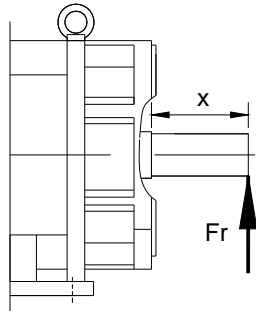

T. 3/2 Radial load tolerance at the end of the shaft extension for its maximum turning speed (nmax).

Series FM7-□□□□-□□□□-E01/E02				
Models	Radial force Fr (N)		X distance (mm)	
	E01	E02	E01	E02
●●●				
FM7-A037-□□□□-●●●	1370	1140	60	60
FM7-A055-□□□□-●●●	1570	1510	80	80
FM7-A075-□□□□-●●●	1570	1510	110	110
FM7-A090-□□□□-●●●	1570	1470	110	110
FM7-A110-□□□□-●●●	1715	590	110	110
FM7-A150-□□□□-●●●	2640	1715	110	110
FM7-A185-□□□□-●●●	2640	1715	110	110
FM7-A220-□□□□-●●●	2640	1715	110	110
FM7-A300-□□□□-●●●	3920	----	140	----
FM7-A370-□□□□-●●●	3920	----	140	----
FM7-A510-□□□□-●●●	4900	4500	140	140
FM7-B120-□□□□-●●●	2640	1715	110	110
FM7-B170-□□□□-●●●	2640	1715	110	110
FM7-B220-□□□□-●●●	3920	----	140	----
FM7-B280-□□□□-●●●	3920	----	140	----
FM7-C215-□□□□-●●●	4900	4500	140	140
FM7-C270-□□□□-●●●	4900	4500	140	140
FM7-E600-□□□□-●●●	8820	----	140	----

Series FM7-D□□□-S1D0-E03/HS3				
Models	Radial force Fr (N)		X distance (mm)	
	E03	HS3	E03	HS3
●●●				
FM7-D055-S1D0-●●●	196	---	60	---
FM7-D075-S1D0-●●●	196	196	60	60
FM7-D110-S1D0-●●●	290	290	80	70
FM7-D150-S1D0-●●●	290	---	80	---
FM7-D185-S1D0-●●●	290	290	80	70
FM7-D220-S1D0-●●●	290	290	80	70



WARNING. When installing transmission pulleys or gears, any blow on the shaft reduces its useful life, the useful life of the bearings and can also damage the feedback device (encoder). Therefore, do not strike the shaft extension under any circumstances.

3.

MECHANICAL CHARACTERISTICS
Radial loads



FM7/FM9

Ref.1107

3.5.1 "Radial load - turning speed" diagrams

Usually, mechanical elements (spindles) or transmission elements (gear boxes) will be coupled to the end of the motor shaft extension. In dynamic conditions, the motor shaft will be subject to forces due to radial loads. If these dynamic forces exceed a certain limit that the shaft was designed for, its useful life will be reduced due to damage caused by fatigue while it's running. Therefore:



WARNING. Make sure that the maximum values of the radial loads applied in dynamic conditions on to the motor shaft extension never exceed the admissible values given by the diagrams depending on the turning speed of the shaft.

Exceeding the radial load limit value on the shaft will increase motor vibration and decrease the life span of its bearings and couplings.

FM7-□□□□-□□□□-E01/E02 series

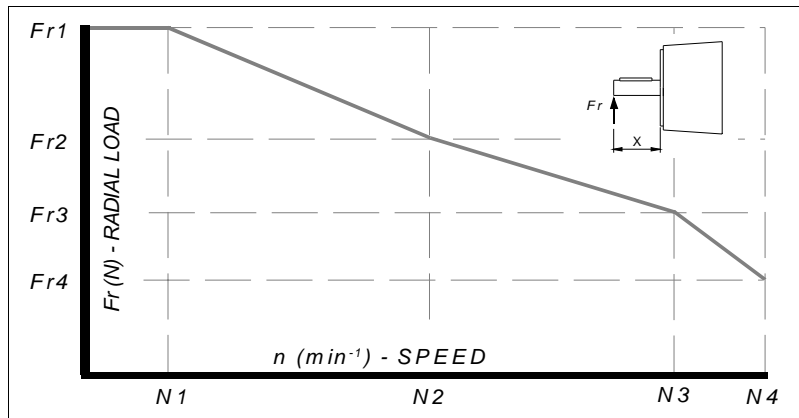

F. 3/5

FM7-□□□□-□□□□-E01/E02 series. Diagram for maximum radial load as a function of turning speed.

T. 3/3 Particular Fri and Ni values according to motor model.

Series FM7-□□□□-□□□□-E01/E02								
Model	Radial force Fri (N)				Turning speed Ni (min ⁻¹)			
	Fr1	Fr2	Fr3	Fr4 (*)	N1	N2	N3	N4 (*)
FM7-A037	1610	1467	1370	1140	5630	7190	9000	12000
FM7-A055	1910	1890	1570	1510	4880	5000	9000	10000
FM7-A075	1990	1890	1570	1510	4310	5965	9000	10000
FM7-A090	1990	1890	1570	1470	4610	5625	9000	10000
FM7-A110	2810	2150	1715	590	1500	4560	9000	10000
FM7-A150	3230	3195	2640	1715	4360	4560	8000	9000
FM7-A185	3880	3000	2640	1715	2340	5265	8000	9000
FM7-A220	3930	2935	2640	1715	1500	6140	8000	9000
FM7-A300	5570	4175	3920	-----	1500	5440	6500	-----
FM7-A370	5720	4435	3920	-----	1640	4385	6500	-----
FM7-A510	5720	5390	4900	4500	2960	3510	5000	6000
FM7-B120	3530	3130	2640	1715	2990	5000	8000	9000
FM7-B170	3530	3130	2640	1715	2990	5000	8000	9000
FM7-B220	5720	4610	3920	-----	2080	3947	6500	-----
FM7-B280	5720	4520	3920	-----	2220	4210	6500	-----
FM7-C215	5720	5565	4900	4500	3340	3510	5000	6000
FM7-C270	5720	5305	4900	4500	3600	3860	5000	6000
FM7-E600	8820	8820	8820	-----	1250	3450	5000	-----

The Fr4 and N4 values are only valid for E02 series motors.

3.

MECHANICAL CHARACTERISTICS
Radial loads



FM7/FM9

Ref.1107

FM7-□□□□-S1D0-E03/HS3 series

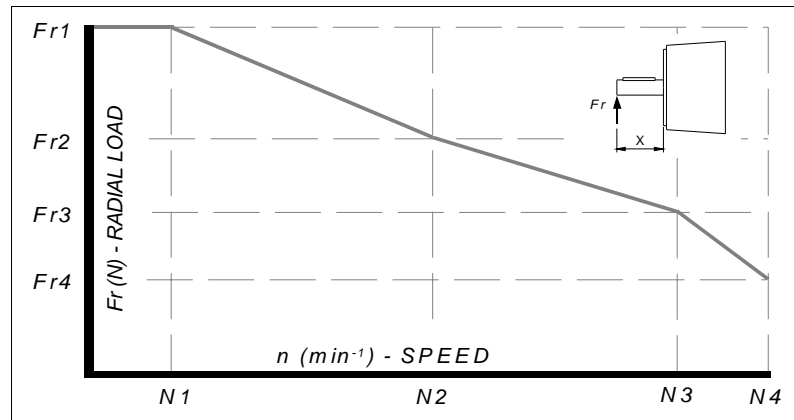

F. 3/6

FM7-D□□□-S1D0-E03 series and FM7-D□□□-S1D0-HS3 series. Diagram for maximum radial load as a function of turning speed.

T. 3/4 Particular Fri and Ni values according to motor model.

Series FM7-D□□□-S1D0-E03								
Model	Radial force Fri (N)				Turning speed Ni (min ⁻¹)			
	Fr1	Fr2	Fr3	Fr4	N1	N2	N3	N4
FM7-D055	1910	1890	1570	196	4880	5000	9000	15000
FM7-D075	1990	1890	1570	196	4310	5965	9000	15000
FM7-D110	2810	2150	1715	290	1500	4560	9000	12000
FM7-D150	3230	3195	2640	290	4360	4560	8000	12000
FM7-D185	3880	3000	2640	290	2340	5265	8000	12000
FM7-D220	3930	2935	2640	290	1500	6140	8000	12000

T. 3/5 Particular Fri and Ni values according to motor model.

Series FM7-D□□□-S1D0-HS3								
Model	Radial force Fri (N)				Turning speed Ni (min ⁻¹)			
	Fr1	Fr2	Fr3	Fr4	N1	N2	N3	N4
FM7-D075	1990	1890	1570	196	4310	5965	9000	15000
FM7-D110	2810	2150	1715	290	1500	4560	9000	12000
FM7-D185	3880	3000	2640	290	2340	5265	8000	12000
FM7-D220	3930	2935	2640	290	1500	6140	8000	12000

3.

MECHANICAL CHARACTERISTICS
Radial loads



FM7/FM9

Ref.1107

3.6 Couplings

3.6.1 Direct coupling

We recommend to follow these indications when coupling the motor shaft directly to the machine axis or to the mechanical spindle itself:

- Couple the motor to the machine whenever the centers of the motor shaft and that of the machine are perfectly aligned. Insert a coupling to make the adjustment if necessary,



WARNING. Do not apply any torsion when aligning it (if the center line of the motor shaft is not in line with that of the machine) because it could damage the bearings and reduce their useful service life.

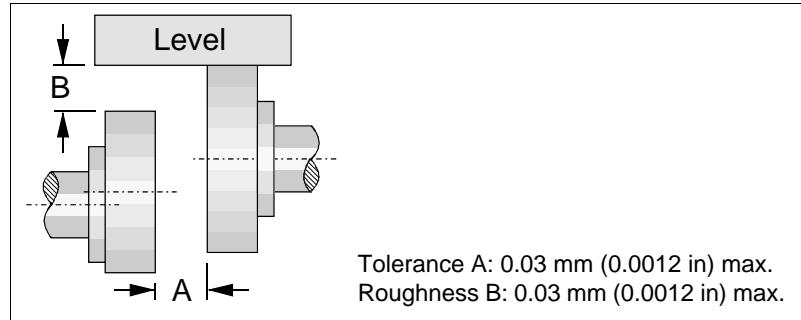

F. 3/7

Precision of direct "motor shaft-machine axis" coupling.

3.6.2 Belt coupling

Note that it makes no sense to talk about this type of coupling when using FM7-D□□□-S1D0-HS3 series motors because they are meant to be coupled directly to the mechanical spindle for air cooling the tool when it starts machining the part, hence avoiding overheating and improving the quality of the part finish.

We recommend to follow these indications when coupling the motor shaft to the machine axis through a belt.

- Make sure that the motor shaft extension is placed parallel to the machine axis and that the center lines of the pulleys and the shafts are at 90° from each other. See figure **F. 3/8**.

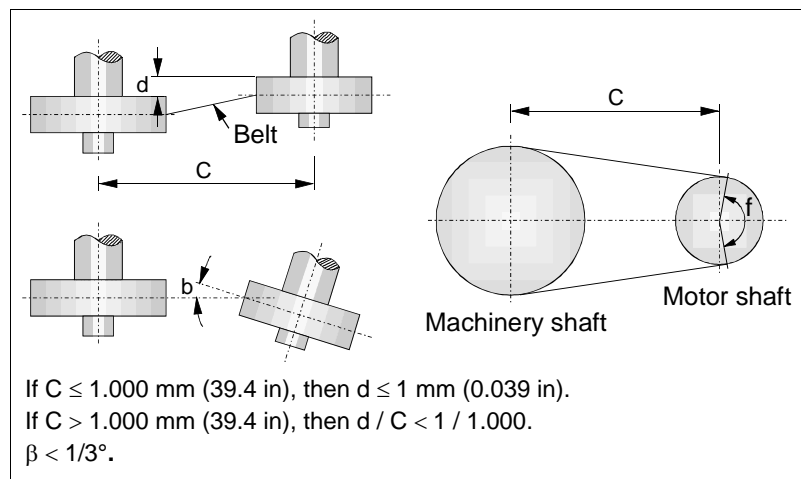

F. 3/8

Belt coupling.

- Verify that the belt angle is the right one, otherwise it may cause vibration or it may slip.

3.
MECHANICAL CHARACTERISTICS
Couplings



FM7/FM9

Ref.1107

- Make sure that the contact angle between the belt and the pulley it rests on is $\phi = 140^\circ$ or greater; otherwise, it may slip. See figure **F. 3/8**.



WARNING. Do not exceed the permissible radial load values on the motor shaft specified in the tables given earlier. Applying too much radial load on the motor shaft extension can seriously affect the life of the bearings reducing their useful service life. See the section on radial loads in this chapter.

3.6.3 Gear coupling

Note that it makes no sense to talk about this type of coupling when using FM7-D□□□-S1D0-HS3 series motors because they are meant to be coupled directly to the mechanical spindle for air cooling the tool when it starts machining the part, hence avoiding overheating and improving the quality of the part finish.

We recommend to follow these indications when coupling the motor shaft to the machine axis through gears.

- Make sure that the motor shaft extension is placed parallel to the machine axis and that the centers of the gears are aligned in parallel fitting perfectly.



WARNING. If the gears do not engage properly, they will deteriorate reducing their useful service life causing vibrations and jeopardizing the dynamic performance of the system.

3.6.4 Mounting a pulley or gears

These indications should be followed when mounting a pulley or gears to the motor shaft.

- Before installing a pulley or gears to the motor shaft, it must be properly balanced.
- Half-key balancing (on shafts with a key) is done with a key that is half as thick as the key specified on the dimensions diagram in this chapter and located in the axial middle of the keyway.
- Avoid mechanical disturbances that could generate vibrations, especially when the motor turns at high speed.

3.

MECHANICAL CHARACTERISTICS
Couplings

FAGOR

FM7/FM9

Ref.1107

3.7 Dimensions

3.7.1 FM7-XXXX-X3XX-E01/E02 series

3.
MECHANICAL CHARACTERISTICS
 Dimensions

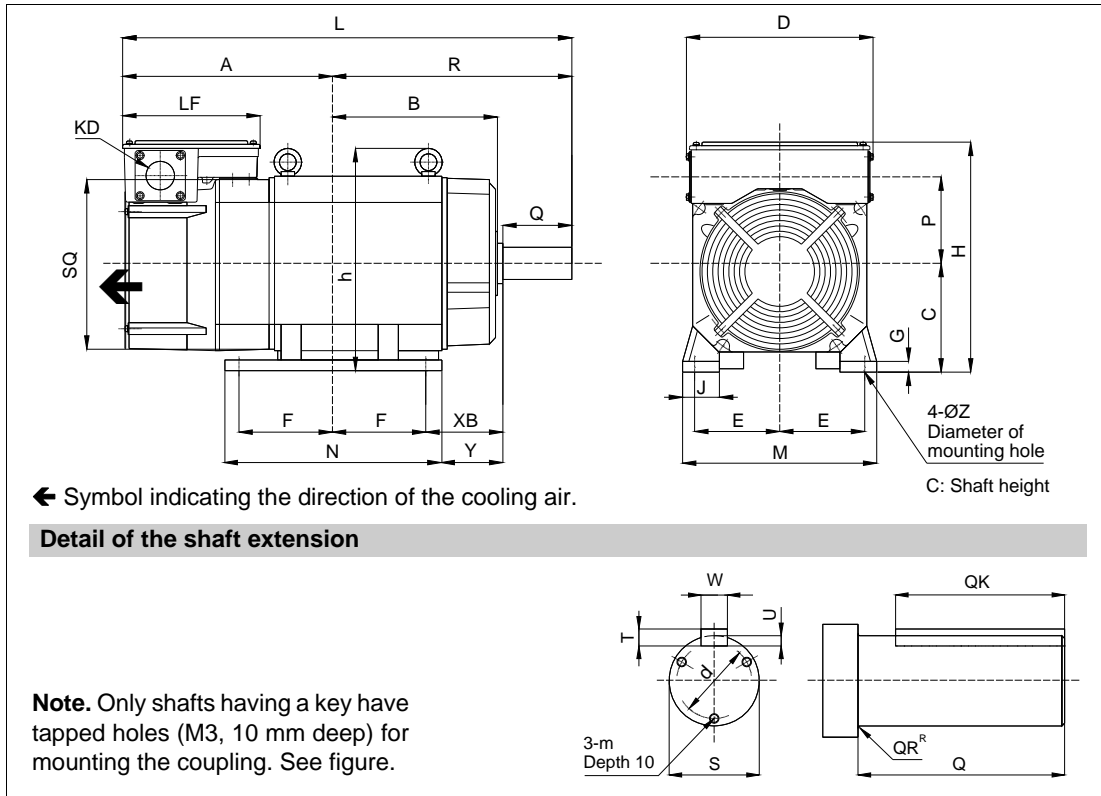

F. 3/9

Dimensions diagram. FM7-□□□□-□3□□-E01/E02 series. Foot mount.

T. 3/6 Motor dimensions in mm. FM7-□□□□-□3□□-E01/E02 series. Foot mount.

Models	A	B	C ⁰ _{-0.5}	D	E	F	G	H	h	J	KD
FM7-A037-□3□□-E01/E02	324	113	100	174	80	70	9	250	----	34	34
FM7-A055-□3□□-E01/E02	286	117	112	204	95	50	10	269	247	75	42.5
FM7-A075-□3□□-E01/E02	296	137	112	204	95	70	10	269	247	75	42.5
FM7-A090-□3□□-E01/E02	317	156	112	204	95	89	10	269	247	75	42.5
FM7-A110-□3□□-E01	264	196	160	279	127	89	16	343	331.5	55	42.5
FM7-A150-□3□□-E01/E02	264	196	160	279	127	89	16	343	331.5	55	42.5
FM7-A185-□3□□-E01/E02	310	212	160	279	127	105	16	343	331.5	55	42.5
FM7-A220-□3□□-E01/E02	313.5	246.5	160	279	127	139.5	16	343	331.5	55	42.5
FM7-A300-□3□□-E01	381	246	180	320	139.5	127	16	407	401	55	61
FM7-A370-□3□□-E01	421	246	180	320	139.5	127	16	407	401	55	61
FM7-A510-□3□□-E01/E02	398	302	225	388	178	155.5	21	540	480	75	61
FM7-B120-□3□□-E01/E02	310	212	160	279	127	105	16	343	331.5	55	42.5
FM7-B170-□3□□-E01/E02	313.5	246.5	160	279	127	139.5	16	343	331.5	55	42.5
FM7-B220-□3□□-E01	381	246	180	320	139.5	127	16	407	401	55	61
FM7-B280-□3□□-E01	421	246	180	320	139.5	127	16	407	401	55	61
FM7-C215-□3□□-E01/E02	398	302	225	388	178	155.5	21	540	480	75	61
FM7-C270-□3□□-E01/E02	429	321	225	388	178	174.5	21	540	480	75	61
FM7-E600-C3B□-E01	589	331.5	225	388	178	228.5	21	540	480	90	61

T. 3/7 Motor dimensions in mm. FM7-□□□□-□3□□-E01/E02 series. Foot mount.

Models	M	N	P	R	XB	Y	Z	SQ	LF	L
FM7-A037-□3□□-E01/E02	188	168	110.5	175	45	31	12	174	225	499
FM7-A055-□3□□-E01/E02	220	129	114	200	70	55	12	204	170	486
FM7-A075-□3□□-E01/E02	220	177	114	250	70	55	12	204	170	546
FM7-A090-□3□□-E01/E02	220	215	114	269	70	55	12	204	170	586
FM7-A110-□3□□-E01	290	223	131	307	108	84	15	260	205	571
FM7-A150-□3□□-E01/E02	290	223	131	307	108	84	15	260	205	571



FM7/FM9

Ref.1107

T. 3/7 Motor dimensions in mm. FM7-□□□□-□3□□-E01/E02 series. Foot mount.

Models	M	N	P	R	XB	Y	Z	SQ	LF	L
FM7-A185-□3□□-E01/E02	290	255	131	323	108	84	15	260	205	633
FM7-A220-□3□□-E01/E02	290	324	131	357.5	108	84	15	260	205	671
FM7-A300-□3□□-E01	320	298	163.5	388	121	99	19	320	261	769
FM7-A370-□3□□-E01	320	298	163.5	388	121	99	19	320	261	809
FM7-A510-□3□□-E01/E02	420	425	235.5	444.5	149	73	24	380	277	842.5
FM7-B120-□3□□-E01/E02	290	255	131	323	108	84	15	260	205	633
FM7-B170-□3□□-E01/E02	290	324	131	357.5	108	84	15	260	205	671
FM7-B220-□3□□-E01	320	298	163.5	388	121	99	19	320	261	769
FM7-B280-□3□□-E01	320	298	163.5	388	121	99	19	320	261	809
FM7-C215-□3□□-E01/E02	420	425	235.5	444.5	149	73	24	380	277	842.5
FM7-C270-□3□□-E01/E02	420	465	235.5	463.5	149	73	24	380	277	892.5
FM7-E600-C3B□-E01	420	590	235.5	476.5	108	65	24	380	277	1065.5

T. 3/8 Shaft dimensions in mm. FM7-□□□□-□3□□-E01/E02 series. Foot mount.

Model	Q	QK	QR	S	T	U	W	d	m
FM7-A037-□3□□-E01/E02	60	45	1	28 h6	7 h11	4	8 h9	22	M4
FM7-A055-□3□□-E01/E02	80	70	2	32 h6	8 h11	5	10 h9	22	M5
FM7-A075-□3□□-E01/E02	110	90	0.5	48 h6	9 h11	5.5	14 h9	40	M5
FM7-A090-□3□□-E01/E02	110	90	0.5	48 h6	9 h11	5.5	14 h9	40	M5
FM7-A110-□3□□-E01	110	90	1	48 h6	9 h11	5.5	14 h9	40	M5
FM7-A150-□3□□-E01/E02	110	90	1	48 h6	9 h11	5.5	14 h9	40	M5
FM7-A185-□3□□-E01/E02	110	90	1	48 h6	9 h11	5.5	14 h9	40	M5
FM7-A220-□3□□-E01/E02	110	90	1	48 h6	9 h11	5.5	14 h9	40	M5
FM7-A300-□3□□-E01	140	110	2	60 m6	11 h11	7	18 h9	50	M6
FM7-A370-□3□□-E01	140	110	2	60 m6	11 h11	7	18 h9	50	M6
FM7-A510-□3□□-E01	140	110	1	70 m6	12 h11	7.5	20 h9	60	M6
FM7-A510-□3□□-E02	140	110	2	60 m6	11 h11	7	18 h9	50	M6
FM7-B120-□3□□-E01/E02	110	90	1	48 h6	9 h11	5.5	14 h9	40	M5
FM7-B170-□3□□-E01/E02	110	90	1	48 h6	9 h11	5.5	14 h9	40	M5
FM7-B220-□3□□-E01	140	110	2	60 m6	11 h11	7	18 h9	50	M6
FM7-B280-□3□□-E01	140	110	2	60 m6	11 h11	7	18 h9	50	M6
FM7-C215-□3□□-E01	140	110	1	70 m6	12 h11	7.5	20 h9	60	M6
FM7-C215-□3□□-E02	140	110	2	60 m6	11 h11	7	18 h9	50	M6
FM7-C270-□3□□-E01	140	110	1	70 m6	12 h11	7.5	20 h9	60	M6
FM7-C270-□3□□-E02	140	110	2	60 m6	11 h11	7	18 h9	50	M6
FM7-E600-C3B□-E01	140	110	1	65 m6	11 h11	7	18 h9	55	M6

3.

MECHANICAL CHARACTERISTICS
Dimensions



FM7/FM9

Ref.1107

3.7.2 Assembling precision

T. 3/9 Assembling precision in mm. FM7-□□□□-□3□□-E01/E02 series. Foot mount.

Model	Parallelism of the Shaft extension	Runout of the shaft extension	
FM7-A037-□3□□-E01/E02	0.03	0.02	
FM7-A055-□3□□-E01/E02	0.03	0.02	
FM7-A075-□3□□-E01/E02	0.033	0.022	
FM7-A090-□3□□-E01/E02	0.033	0.022	
FM7-A110-□3□□-E01	0.033	0.022	
FM7-A150-□3□□-E01/E02	0.033	0.022	
FM7-A185-□3□□-E01/E02	0.033	0.022	
FM7-A220-□3□□-E01/E02	0.033	0.022	
FM7-A300-□3□□-E01	0.042	0.028	
FM7-A370-□3□□-E01	0.042	0.028	
FM7-A510-□3□□-E01/E02	0.042	0.028	
FM7-B120-□3□□-E01/E02	0.033	0.022	
FM7-B170-□3□□-E01/E02	0.033	0.022	
FM7-B220-□3□□-E01	0.042	0.028	
FM7-B280-□3□□-E01	0.042	0.028	
FM7-C215-□3□□-E01/E02	0.042	0.028	
FM7-C270-□3□□-E01/E02	0.042	0.028	
FM7-E600-C3B□-E01	0.042	0.028	

3.
MECHANICAL CHARACTERISTICS
 Dimensions

3.7.3 FM7-XXXX-X1XX-E01/E02 series

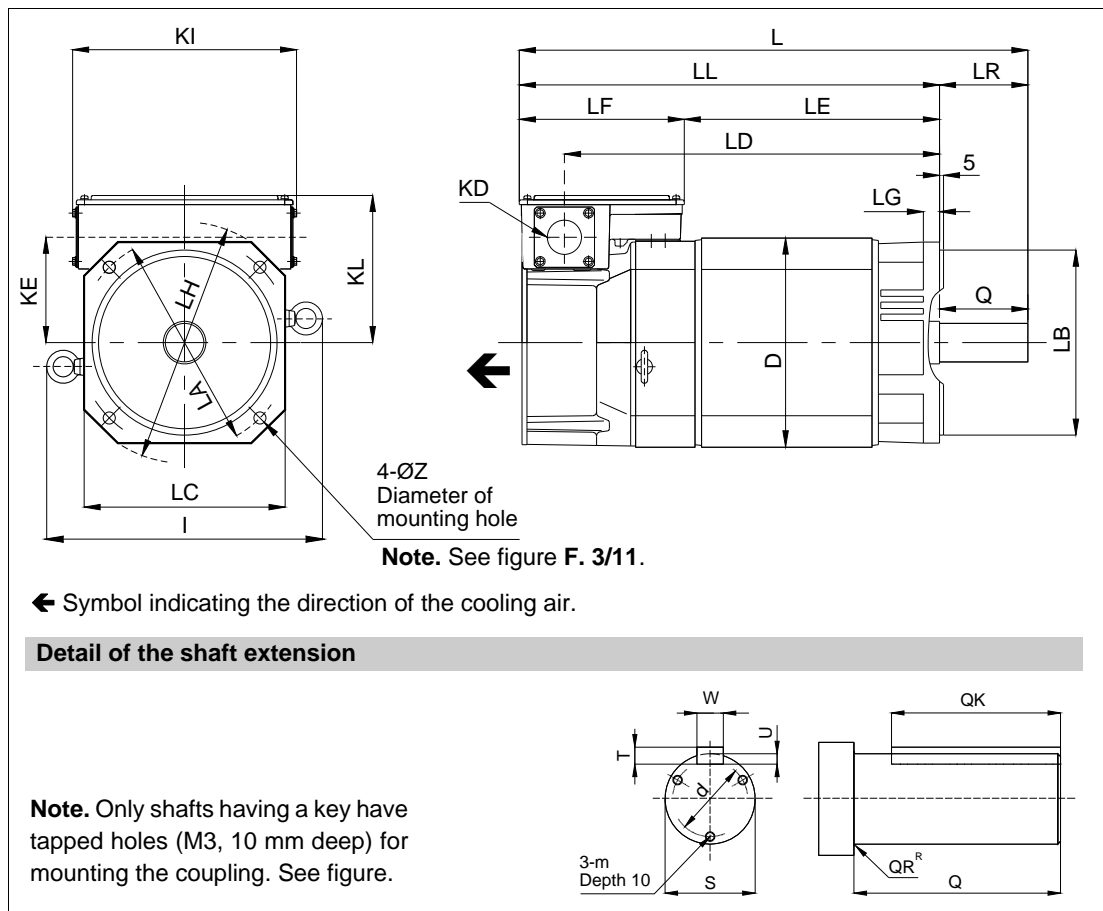

F. 3/10

Dimensions diagram. FM7-□□□□-□1□□-E01/E02 series. Flange mount.



FM7/FM9

Ref.1107

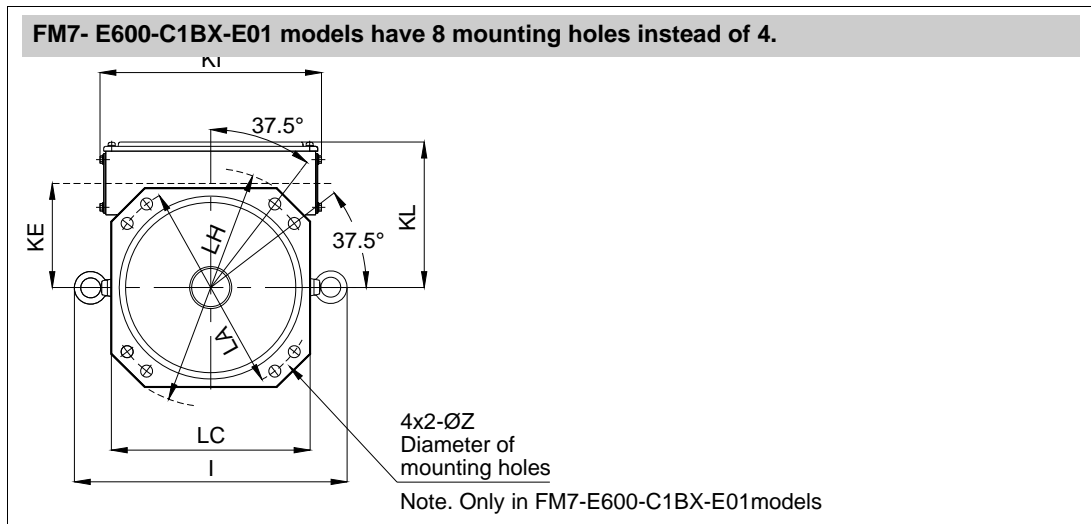

F. 3/11

Layout out the flange mounting holes in FM7-E600-C1B□-E01series.

T. 3/10 Motor dimensions in mm. FM7-□□□□-□1□□-E01/E02 series. Flange mount.

Model	L	LA	LB	LC	LG	LH	LL	LR	LD	LE
FM7-A037-□1□□-E01/E02	499	185	150 h7	174	12	220	407	60	399	214
FM7-A055-□1□□-E01/E02	486	215	180 h7	204	16	250	406	80	354	227
FM7-A075-□1□□-E01/E02	546	215	180 h7	204	16	250	436	110	384	257
FM7-A090-□1□□-E01/E02	586	215	180 h7	204	16	250	476	110	424	297
FM7-A110-□1□□-E01/E02	571	265	230 h7	250	20	300	461	110	404.5	256
FM7-A150-□1□□-E01/E02	571	265	230 h7	250	20	300	461	110	404.5	256
FM7-A185-□1□□-E01/E02	633	265	230 h7	250	20	300	523	110	466.5	318
FM7-A220-□1□□-E01/E02	671	265	230 h7	250	20	300	561	110	504.5	355
FM7-A300-□1□□-E01	769	350	300 h7	320	20	385	629	140	557.5	362
FM7-A370-□1□□-E01	809	350	300 h7	320	20	385	669	140	597.5	402
FM7-A510-□1□□-E01/E02	847	400	350 h7	370	22	450	707	140	632.5	430
FM7-B120-□1□□-E01/E02	633	265	230 h7	250	20	300	523	110	466.5	318
FM7-B170-□1□□-E01/E02	671	265	230 h7	250	20	300	561	110	504.5	355
FM7-B220-□1□□-E01	769	350	300 h7	320	20	385	629	140	557.5	362
FM7-B280-□1□□-E01	809	350	300 h7	320	20	385	669	140	597.5	402
FM7-C215-□1□□-E01/E02	847	400	350 h7	370	22	450	707	140	632.5	430
FM7-C270-□1□□-E01/E02	897	400	350 h7	370	22	450	757	140	682.5	480
FM7-E600-C1B□-E01	1065.5	400	350 h7	370	22	450	925.5	140	851	648.5

T. 3/11 Motor dimensions in mm. FM7-□□□□-□1□□-E01/E02 series. Flange mount.

Model	LF	Z	D	I	KD	KL	KI	KE	
FM7-A037-□1□□-E01/E02	225	11	174	-----	34	150	174	110.5	
FM7-A055-□1□□-E01/E02	170	15	204	270	42.5	158	204	114	
FM7-A075-□1□□-E01/E02	171	15	204	270	42.5	158	204	114	
FM7-A090-□1□□-E01/E02	171	15	204	270	42.5	158	204	114	
FM7-A110-□1□□-E01/E02	205	15	260	343	42.5	183	279	131	
FM7-A150-□1□□-E01/E02	205	15	260	343	42.5	183	279	131	
FM7-A185-□1□□-E01/E02	205	15	260	343	42.5	183	279	131	
FM7-A220-□1□□-E01/E02	205	15	260	343	42.5	183	279	131	
FM7-A300-□1□□-E01	261	19	320	440	61	227	320	163.5	
FM7-A370-□1□□-E01	261	19	320	440	61	227	320	163.5	
FM7-A510-□1□□-E01/E02	277	24	380	504	61	315	388	235.5	
FM7-B120-□1□□-E01/E02	205	15	260	343	42.5	183	279	131	
FM7-B170-□1□□-E01/E02	205	15	260	343	42.5	181	279	131	
FM7-B220-□1□□-E01	261	19	320	440	61	227	320	163.5	
FM7-B280-□1□□-E01	261	19	320	440	61	227	320	163.5	
FM7-C215-□1□□-E01/E02	277	24	380	504	61	315	388	235.5	
FM7-C270-□1□□-E01/E02	277	24	380	504	61	315	388	235.5	
FM7-E600-C1B□-E01	277	24	380	526	61	315	388	235.5	

3.

MECHANICAL CHARACTERISTICS
Dimensions



FM7/FM9

Ref.1107

3.

MECHANICAL CHARACTERISTICS
Dimensions

T. 3/12 Shaft dimensions in mm. FM7-□□□□-□1□□-E01/E02 series. Flange mount.

Models	Q	QK	QR	S	T	U	W	d	m
FM7-A037-□1□□-E01/E02	60	45	1	28 h6	7 h11	4	8 h9	22	M4
FM7-A055-□1□□-E01/E02	80	70	2	32 h6	8 h11	5	10 h9	22	M5
FM7-A075-□1□□-E01/E02	110	90	0.5	48 h6	9 h11	5.5	14 h9	40	M5
FM7-A090-□1□□-E01/E02	110	90	0.5	48 h6	9 h11	5.5	14 h9	40	M5
FM7-A110-□1□□-E01/E02	110	90	1	48 h6	9 h11	5.5	14 h9	40	M5
FM7-A110-□1□□-E02	110	90	0.5	48 h6	9 h11	5.5	14 h9	40	M5
FM7-A150-□1□□-E01/E02	110	90	1	48 h6	9 h11	5.5	14 h9	40	M5
FM7-A185-□1□□-E01/E02	110	90	1	48 h6	9 h11	5.5	14 h9	40	M5
FM7-A220-□1□□-E01/E02	110	90	1	48 h6	9 h11	5.5	14 h9	40	M5
FM7-A300-□1□□-E01	140	110	2	60 m6	11 h11	7	18 h9	50	M6
FM7-A370-□1□□-E01	140	110	2	60 m6	11 h11	7	18 h9	50	M6
FM7-A510-□1□□-E01	140	110	1	70 m6	12 h11	7.5	20 h9	60	M6
FM7-A510-□1□□-E02	140	110	2	60 m6	11 h11	7	18 h9	50	M6
FM7-B120-□1□□-E01/E02	110	90	1	48 h6	9 h11	5.5	14 h9	40	M5
FM7-B170-□1□□-E01/E02	110	90	1	48 h6	9 h11	5.5	14 h9	40	M5
FM7-B220-□1□□-E01	140	110	2	60 m6	11 h11	7	18 h9	50	M6
FM7-B280-□1□□-E01	140	110	2	60 m6	11 h11	7	18 h9	50	M6
FM7-C215-□1□□-E01	140	110	1	70 m6	12 h11	7.5	20 h9	60	M6
FM7-C215-□1□□-E02	140	110	2	60 m6	11 h11	7	18 h9	50	M6
FM7-C270-□1□□-E01	140	110	1	70 m6	12 h11	7.5	20 h9	60	M6
FM7-C270-□1□□-E02	140	110	2	60 m6	11 h11	7	18 h9	50	M6
FM7-E600-C1B□-E01	140	110	1	65 m6	11 h11	7	18 h9	55	M6

3.7.4 Assembling precision

T. 3/13 Assembling precision in mm. FM7-□□□□-□1□□-E01/E02 series. Flange mount.

Models	Runout of the shaft extension	Concentricity of the fitting diameter between the flange and the shaft	Concentricity of the support face of the flange with respect to the machine axis
FM7-A037-□1□□-E01/E02	0.02	0.04	0.04
FM7-A055-□1□□-E01/E02	0.02	0.04	0.04
FM7-A075-□1□□-E01/E02	0.022	0.04	0.04
FM7-A090-□1□□-E01/E02	0.022	0.04	0.04
FM7-A110-□1□□-E01/E02	0.022	0.046	0.04
FM7-A150-□1□□-E01/E02	0.022	0.046	0.04
FM7-A185-□1□□-E01/E02	0.022	0.046	0.04
FM7-A220-□1□□-E01/E02	0.022	0.046	0.04
FM7-A300-□1□□-E01	0.028	0.048	0.06
FM7-A370-□1□□-E01	0.028	0.048	0.06
FM7-A510-□1□□-E01/E02	0.028	0.07	0.072
FM7-B120-□1□□-E01/E02	0.022	0.046	0.04
FM7-B170-□1□□-E01/E02	0.022	0.046	0.04
FM7-B220-□1□□-E01	0.028	0.048	0.06
FM7-B280-□1□□-E01	0.028	0.048	0.06
FM7-C215-□1□□-E01/E02	0.028	0.070	0.072
FM7-C270-□1□□-E01/E02	0.028	0.070	0.072
FM7-E600-C1B□-E01	0.028	0.070	0.072



FM7/FM9

Ref.1107

3.7.5 FM7-XXXX-X5XX-E01/E02 series

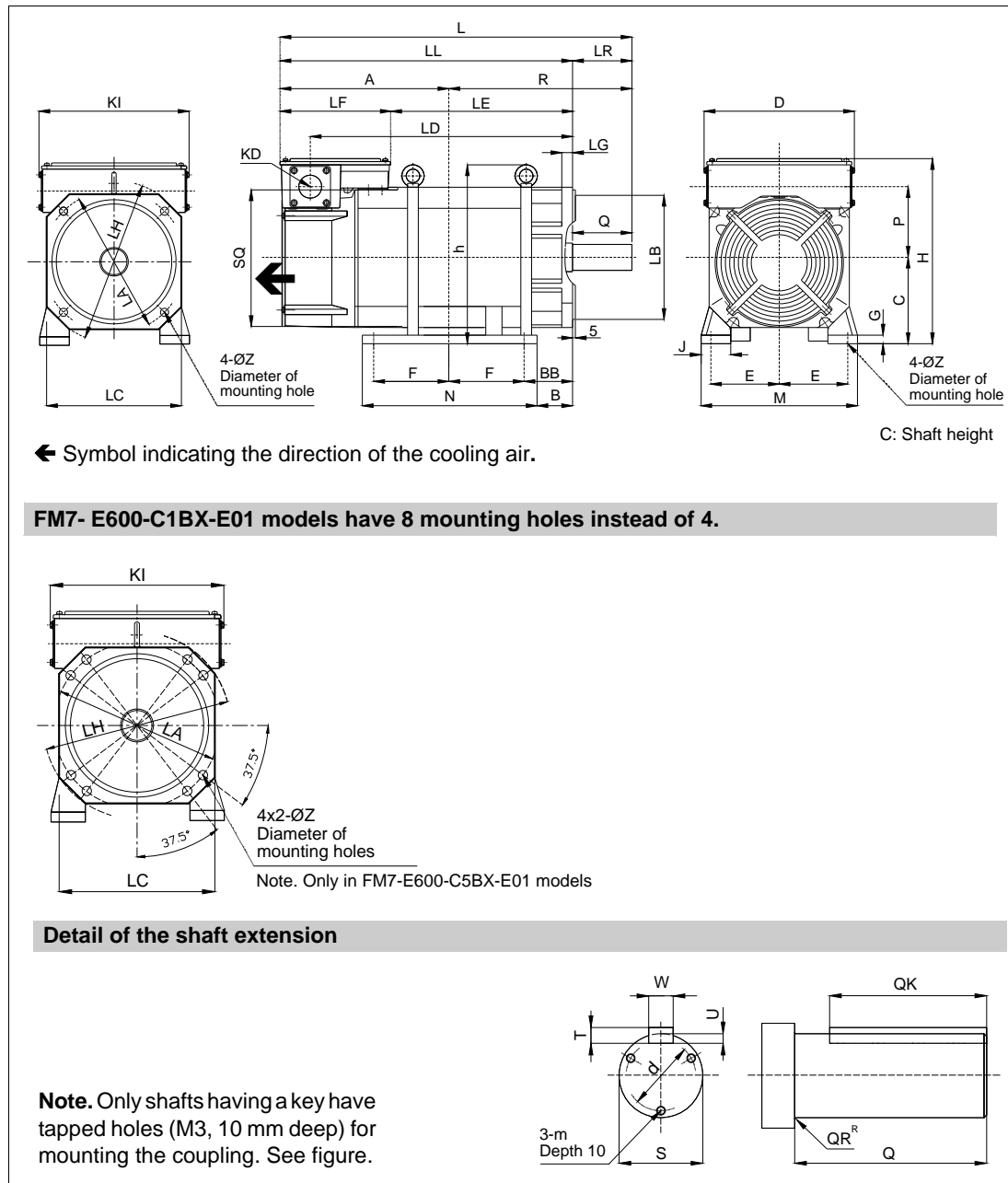

F. 3/12

Dimensions diagram. FM7-□□□□-□5□□-E01/E02 series. Foot + Flange mount.

T. 3/14 Motor dimensions in mm. FM7-□□□□-□5□□-E01/E02 series. Foot + Flange mount.

Models	L	LL	LR	LD	LG	LB	KI	LA	LH	LC
FM7-A110-□5□□-E01	571	461	110	404.5	20	230 h7	279	265	300	250
FM7-A150-□5□□-E01/E02	571	461	110	404.5	20	230 h7	279	265	300	250
FM7-A185-□5□□-E01/E02	633	523	110	466.5	20	230 h7	279	265	300	250
FM7-A220-□5□□-E01/E02	671	561	110	504.5	20	230 h7	279	265	300	250
FM7-A300-□5□□-E01	769	629	140	557.5	20	300 h7	320	350	385	320
FM7-A370-□5□□-E01	809	669	140	597.5	20	300 h7	320	350	385	320
FM7-A510-□5□□-E01/E02	847	707	140	632.5	22	350 h7	388	400	450	370
FM7-B120-□5□□-E01/E02	633	523	110	466.5	20	230 h7	279	265	300	250
FM7-B170-□5□□-E01/E02	671	561	110	504.5	20	230 h7	279	265	300	250
FM7-B220-□5□□-E01	769	629	140	557.5	20	300 h7	320	350	385	320
FM7-B280-□5□□-E01	809	669	140	597.5	20	300 h7	320	350	385	320
FM7-C215-□5□□-E01/E02	847	707	140	632.5	22	350 h7	388	400	450	370
FM7-C270-□5□□-E01/E02	897	757	140	632.5	22	350 h7	388	400	450	370
FM7-E600-C5B□-E01	1065.5	925.5	140	851	22	350 h7	388	400	450	356

3.
MECHANICAL CHARACTERISTICS
 Dimensions



FM7/FM9

Ref.1107

3.

MECHANICAL CHARACTERISTICS
Dimensions

T. 3/15 Motor dimensions in mm. FM7-□□□□-□5□□-E01/E02 series. Foot + Flange mount.

Models	LE	LF	R	Z	A	D	E	F	G
FM7-A110-□5□□-E01	256	205	307	15	264	279	127	89	16
FM7-A150-□5□□-E01/E02	256	205	307	15	264	279	127	89	16
FM7-A185-□5□□-E01/E02	318	205	323	15	310	279	127	105	16
FM7-A220-□5□□-E01/E02	355	205	357.5	15	313.5	279	127	139.5	16
FM7-A300-□5□□-E01	362	261	388	19	381	320	139.5	127	16
FM7-A370-□5□□-E01	402	261	388	19	421	320	139.5	127	16
FM7-A510-□5□□-E01/E02	430	277	449	24	398	388	178	155.5	21
FM7-B120-□5□□-E01/E02	318	205	323	15	310	279	127	105	16
FM7-B170-□5□□-E01/E02	355	205	357.5	15	313.5	279	127	139.5	16
FM7-B220-□5□□-E01	362	261	388	19	381	320	139.5	127	16
FM7-B280-□5□□-E01	402	261	388	19	421	320	139.5	127	16
FM7-C215-□5□□-E01/E02	430	277	444.5	24	398	388	178	155.5	21
FM7-C270-□5□□-E01/E02	480	277	463.5	24	429	388	178	174.5	21
FM7-E600-C5B□-E01	648.5	277	476.5	24	589	388	178	228.5	21

T. 3/16 Motor dimensions in mm. FM7-□□□□-□5□□-E01/E02 series. Foot + Flange mount.

Models	C ⁰ _{-0.5}	H	h	J	KD	M	N	B	BB	P	SQ
FM7-A110-□5□□-E01	160	343	331.5	55	42.5	290	223	84	108	131	260
FM7-A150-□5□□-E01/E02	160	343	331.5	55	42.5	290	223	84	108	131	260
FM7-A185-□5□□-E01/E02	160	343	331.5	55	42.5	290	255	84	108	131	260
FM7-A220-□5□□-E01/E02	160	343	331.5	55	42.5	290	324	84	108	131	260
FM7-A300-□5□□-E01	180	407	401	55	61	320	298	99	121	163.5	320
FM7-A370-□5□□-E01	180	407	401	55	61	320	298	99	121	163.5	320
FM7-A510-□5□□-E01/E02	225	540	480	75	61	420	425	77.5	153.5	235.5	380
FM7-B120-□5□□-E01/E02	160	343	331.5	55	42.5	290	255	84	108	131	260
FM7-B170-□5□□-E01/E02	160	343	331.5	55	42.5	290	324	84	108	131	260
FM7-B220-□5□□-E01	180	407	401	55	61	320	298	99	121	163.5	320
FM7-B280-□5□□-E01	180	407	401	55	61	320	298	99	121	163.5	320
FM7-C215-□5□□-E01/E02	225	540	480	75	61	420	425	77.5	153.5	235.5	380
FM7-C270-□5□□-E01/E02	225	540	480	75	61	420	425	73	153.5	235.5	380
FM7-E600-C5B□-E01	225	540	480	90	61	420	590	65	108	235.5	380

T. 3/17 Shaft dimensions in mm. FM7-□□□□-□5□□-E01/E02 series. Foot + Flange mount.

Model	Q	QK	QR	S	T	U	W	d	m
FM7-A110-□5□□-E01	110	90	1	48 h6	9 h11	5.5	14 h9	40	M5
FM7-A150-□5□□-E01/E02	110	90	1	48 h6	9 h11	5.5	14 h9	40	M5
FM7-A185-□5□□-E01/E02	110	90	1	48 h6	9 h11	5.5	14 h9	40	M5
FM7-A220-□5□□-E01/E02	110	90	1	48 h6	9 h11	5.5	14 h9	40	M5
FM7-A300-□5□□-E01	140	110	2	60 m6	11 h11	7	18 h9	50	M6
FM7-A370-□5□□-E01	140	110	2	60 m6	11 h11	7	18 h9	50	M6
FM7-A510-□5□□-E01	140	110	1	70 m6	12 h11	7.5	20 h9	60	M6
FM7-A510-□5□□-E02	140	110	2	60 m6	11 h11	7	18 h9	50	M6
FM7-B120-□5□□-E01/E02	110	90	1	48 h6	9 h11	5.5	14 h9	40	M5
FM7-B170-□5□□-E01/E02	110	90	1	48 h6	9 h11	5.5	14 h9	40	M5
FM7-B220-□5□□-E01	140	110	2	60 m6	11 h11	7	18 h9	50	M6
FM7-B280-□5□□-E01	140	110	2	60 m6	11 h11	7	18 h9	50	M6
FM7-C215-□5□□-E01	140	110	1	70 m6	12 h11	7.5	20 h9	60	M6
FM7-C215-□5□□-E02	140	110	2	60 m6	11 h11	7	18 h9	50	M6
FM7-C270-□5□□-E01	140	110	1	70 m6	12 h11	7.5	20 h9	60	M6
FM7-C270-□5□□-E02	140	110	2	60 m6	11 h11	7	18 h9	50	M6
FM7-E600-C5B□-E01	140	110	1	65 m6	11 h11	7	18 h9	55	M6



FM7/FM9

Ref.1107

3.7.6 Assembling precision

T. 3/18 Assembling precision in mm. FM7-□□□□-□5□□-E01/E02 series. Foot + Flange mount.

Model	Parallelism of the shaft extension	Runout of the shaft extension	Concentricity of the fitting diameter between the flange and the shaft	Concentricity of the support face of the flange with respect to the machine axis	Perpendicularity of the support side of the flange with respect to the foot
FM7-A110-□5□□-E01	0.033	0.022	0.046	0.04	0.130
FM7-A150-□5□□-E01/E02	0.033	0.022	0.046	0.04	0.130
FM7-A185-□5□□-E01/E02	0.033	0.022	0.046	0.04	0.130
FM7-A220-□5□□-E01/E02	0.033	0.022	0.046	0.04	0.130
FM7-A300-□5□□-E01	0.042	0.028	0.048	0.06	0.176
FM7-A370-□5□□-E01	0.042	0.028	0.048	0.06	0.176
FM7-A510-□5□□-E01/E02	0.042	0.028	0.048	0.06	0.176
FM7-B120-□5□□-E01/E02	0.033	0.022	0.046	0.04	0.130
FM7-B170-□5□□-E01/E02	0.033	0.022	0.046	0.04	0.130
FM7-B220-□5□□-E01	0.042	0.028	0.048	0.06	0.176
FM7-B280-□5□□-E01	0.042	0.028	0.048	0.06	0.176
FM7-C215-□5□□-E01/E02	0.042	0.028	0.048	0.06	0.176
FM7-C270-□5□□-E01/E02	0.042	0.028	0.048	0.06	0.176
FM7-E600-C5B□-E01	0.042	0.028	0.070	0.072	0.207

3.

MECHANICAL CHARACTERISTICS
Dimensions

FAGOR 

FM7/FM9

Ref.1107

3.7.7 FM9-XXXX-C5CX-E01 series

3.

MECHANICAL CHARACTERISTICS
Dimensions

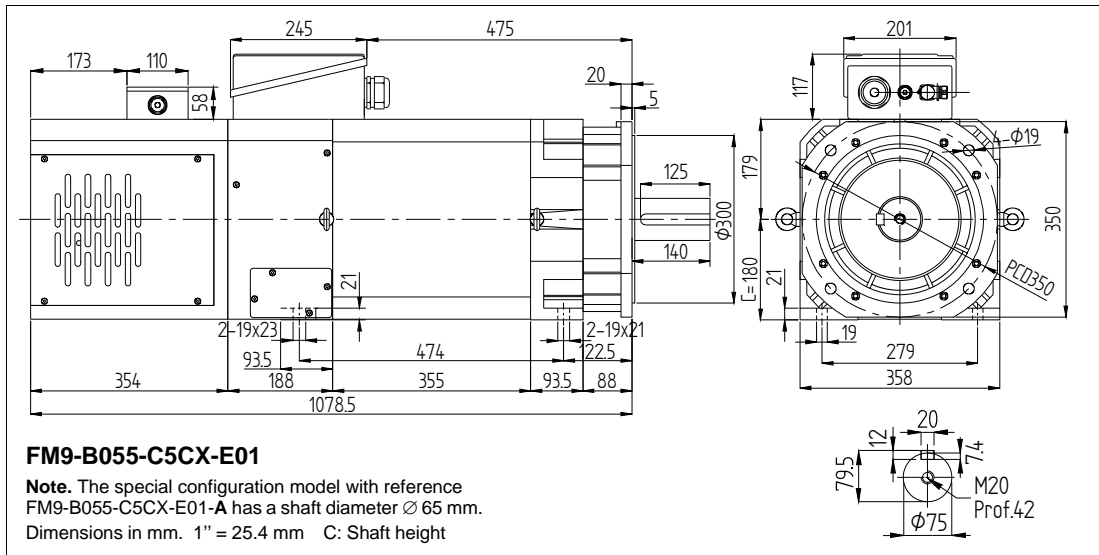

F. 3/13

Dimensions diagram. FM9-B055-C5C□-E01 model.

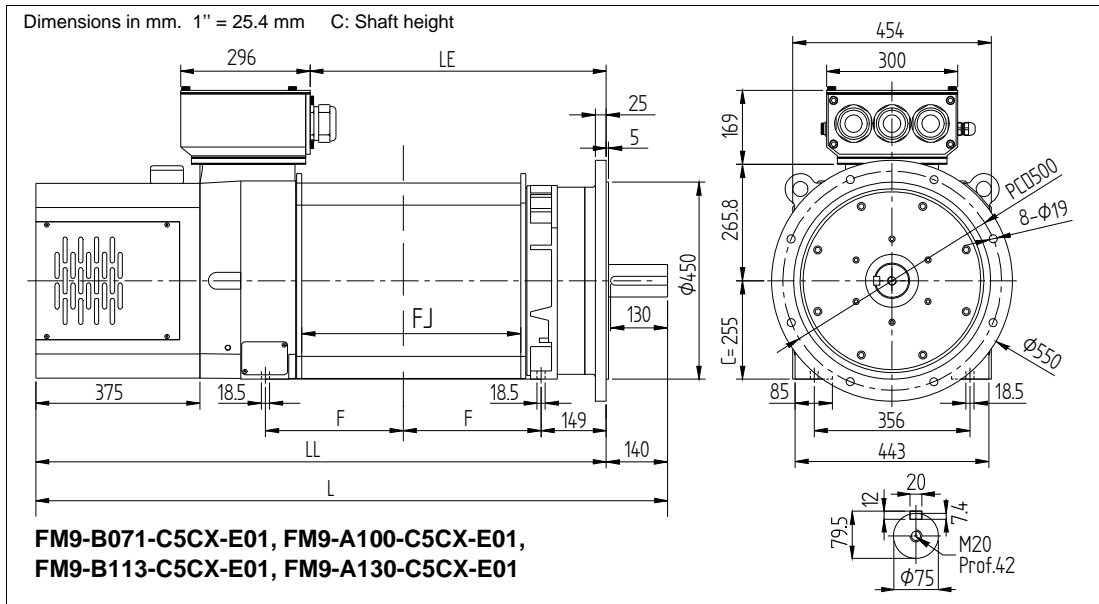

F. 3/14

Dimensions diagram. FM9-□□□□-C5C□-E01 models.

T. 3/19 Motor dimensions in mm. FM9-□□□□-C5C□-E01 series. Foot + Flange mount.

Models	L	LL	LE	F	FJ				
FM9-B071-C5C□-E01	1259	1119	492	222.5	315				
FM9-A100-C5C□-E01	1259	1119	492	222.5	315				
FM9-B113-C5C□-E01	1444	1304	677	315	500				
FM9-A130-C5C□-E01	1354	1214	587	270	410				

3.7.8 Assembling precision

T. 3/20 Assembling precision in mm. FM9-□□□□-C5C□-E01 series. Foot + Flange mount.

Models	Runout of the shaft extension	Concentricity of the fitting diameter between the flange and the shaft	Concentricity of the support face of the flange with respect to the machine axis	Perpendicularity of the support side of the flange with respect to the foot
FM9-B055-C5C□-E01	0.05	0.13	0.08	0.1
FM9-B071-C5C□-E01	0.05	0.13	0.08	0.1
FM9-A100-C5C□-E01	0.05	0.13	0.08	0.1
FM9-B113-C5C□-E01	0.05	0.13	0.08	0.1
FM9-A130-C5C□-E01	0.05	0.13	0.08	0.1



FM7/FM9

Ref.1107

3.7.9 FM7-DXXX-S1D0-E03 series

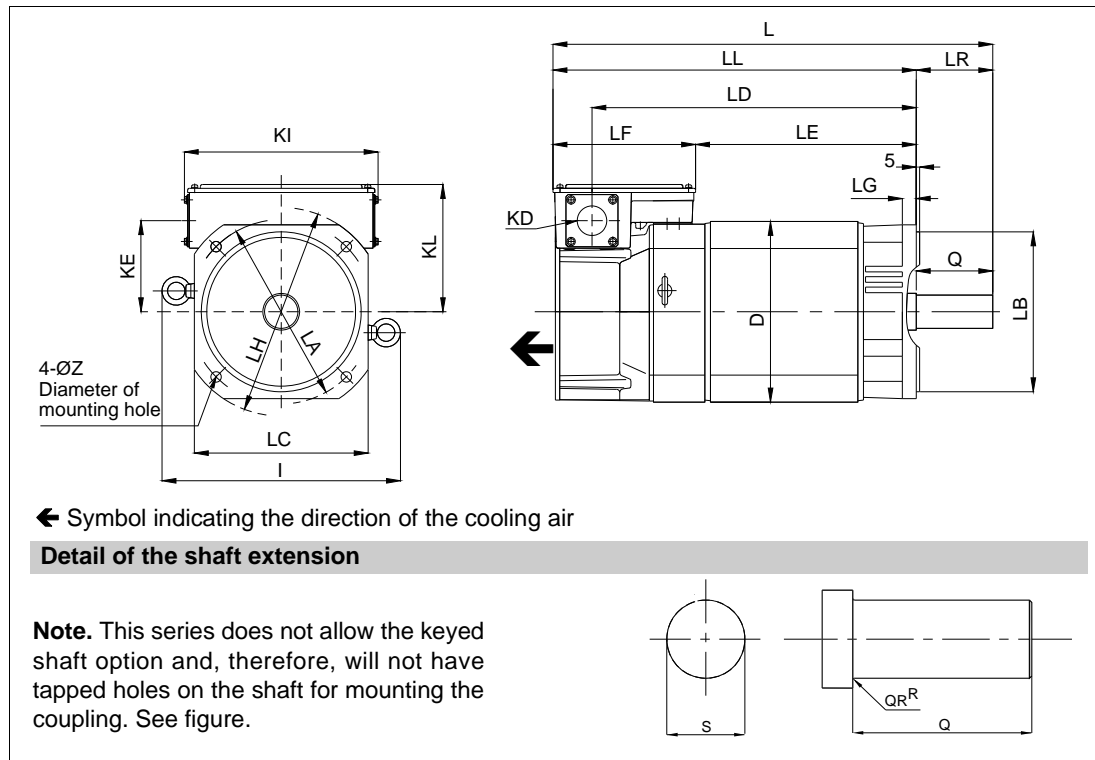

F. 3/15

Dimensions diagram. FM7-D□□□-S1D0-E03 series. Flange mount.

T. 3/21 Motor dimensions in mm. FM7-D□□□-S1D0-E03 series. Flange mount.

Models	L	LA	LB	LC	LG	LH	LL	LR	LD	LE	LF
FM7-D055-S1D0-E03	475	215	180 h7	204	20	250	415	60	353	226	171
FM7-D075-S1D0-E03	506	215	180 h7	204	20	250	446	60	401	256	190
FM7-D110-S1D0-E03	556	265	230 h7	250	25	300	476	80	420	271	205
FM7-D150-S1D0-E03	556	265	230 h7	250	25	300	476	80	420	271	205
FM7-D185-S1D0-E03	618	265	230 h7	250	25	300	538	80	482	333	205
FM7-D220-S1D0-E03	656	265	230 h7	250	25	300	576	80	520	371	205

T. 3/22 Motor and shaft dimensions in mm. FM7-D□□□-S1D0-E03 series. Flange mount.

Models	Z	D	I	KD	KL	KI	KE	Q	QR	S
FM7-D055-S1D0-E03	15	204	270	42.5	158	204	114	60	0.5	28 h6
FM7-D075-S1D0-E03	15	204	270	42.5	164	250	114	60	0.5	28 h6
FM7-D110-S1D0-E03	15	260	343	42.5	183	279	131	80	0.5	38 h6
FM7-D150-S1D0-E03	15	260	343	42.5	183	279	131	80	0.5	38 h6
FM7-D185-S1D0-E03	15	260	343	42.5	183	279	131	80	0.5	38 h6
FM7-D220-S1D0-E03	15	260	343	42.5	183	279	131	80	0.5	38 h6

3.7.10 Assembling precision

T. 3/23 Assembling precision in mm. FM7-D□□□-S1D0-E03 series. Flange mount.

Models	Runout of the shaft extension	Concentricity of the fitting diameter between the flange and the shaft	Concentricity of the support face of the flange with respect to the machine axis
FM7-D055-S1D0-E03	0.02	0.04	0.04
FM7-D075-S1D0-E03	0.022	0.04	0.04
FM7-D110-S1D0-E03	0.022	0.046	0.04
FM7-D150-S1D0-E03	0.022	0.046	0.04
FM7-D185-S1D0-E03	0.022	0.046	0.04
FM7-D220-S1D0-E03	0.022	0.046	0.04

3.
MECHANICAL CHARACTERISTICS
 Dimensions



FM7/FM9

Ref.1107

3.7.11 FM7-DXXX-S1D0-HS3 series

3.

MECHANICAL CHARACTERISTICS
Dimensions

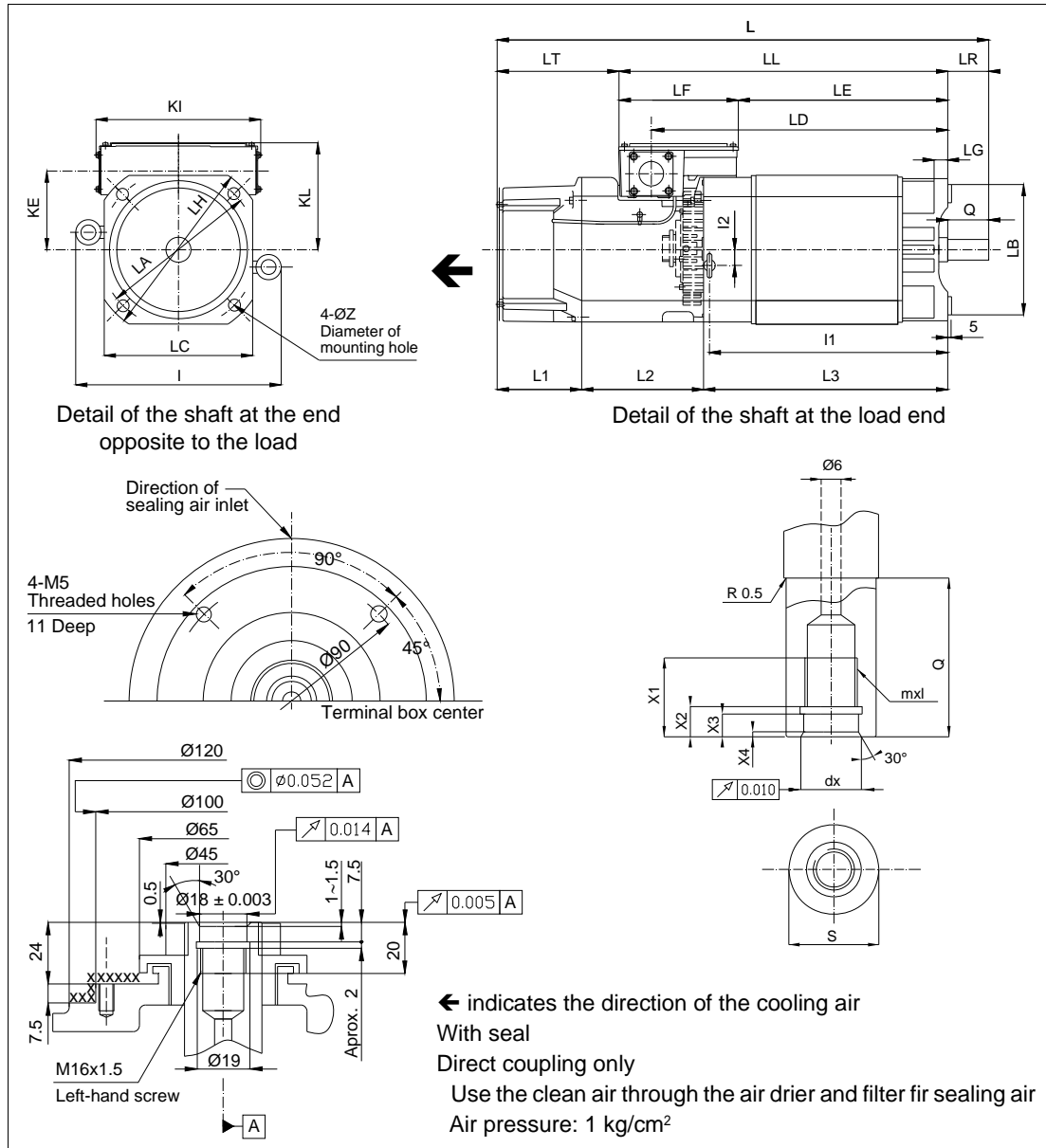

F. 3/16

Dimensions diagram. FM7-D□□□-S1D0-HS3 series. Flange mount.

T. 3/24 Motor dimensions in mm. FM7-D□□□-S1D0-HS3 series. Flange mount.

Series FM7-D□□□-S1D0-HS3											
Model	L	LA	LB	LC	LG	LH	LL	LR	LD	LE	LF
FM7-D075-S1D0-HS3	715	215	180 h7	204	20	250	446	60	401	256	190
FM7-D110-S1D0-HS3	751	265	230 h7	250	25	300	476	70	420	271	205
FM7-D185-S1D0-HS3	813	265	230 h7	250	25	300	538	70	482	333	205
FM7-D220-S1D0-HS3	851	265	230 h7	250	25	300	576	70	520	371	205

T. 3/25 Motor dimensions in mm. FM7-D□□□-S1D0-HS3 series. Flange mount.

Series FM7-D□□□-S1D0-HS3										
Models	Z	D	I	KD	KL	KI	KE	L1	L2	L3
FM7-D075-S1D0-HS3	15	204	271	42.5	158	250	114	137	210	308
FM7-D110-S1D0-HS3	15	260	343	42.5	183	279	131	142	208	331
FM7-D185-S1D0-HS3	15	260	343	42.5	183	279	131	142	208	393
FM7-D220-S1D0-HS3	15	260	343	42.5	183	279	131	142	208	431



FM7/FM9

Ref.1107

T. 3/26 Motor and shaft dimensions in mm. FM7-D□□□-S1D0-HS3 series. Flange mount.

Series FM7-D□□□-S1D0-HS3										
Models	I1	I2	Q	mxl	S	X1	X2	X3	X4	dx
FM7-D075-S1D0-HS3	288	33	60	M12 x 1.5	28 h6	31	14.5	13	1	16
FM7-D110-S1D0-HS3	320	30	70	M16 x 1.5	38 h6	38	17	15	1±1.5	20
FM7-D185-S1D0-HS3	382	30	70	M16 x 1.5	38 h6	38	17	15	1±1.5	20
FM7-D220-S1D0-HS3	420	30	70	M16 x 1.5	38 h6	38	17	15	1±1.5	20

3.7.12 Assembling precision

T. 3/27 Assembling precision in mm. FM7-D□□□-S1D0-HS3 series. Flange mount.

Series FM7-D□□□-S1D0-HS3			
Models	Runout of the shaft extension	Concentricity of the fitting diameter between the flange and the shaft	Concentricity of the support face of the flange with respect to the machine axis
FM7-D075-S1D0-HS3	0.022	0.04	0.04
FM7-D110-S1D0-HS3	0.022	0.046	0.04
FM7-D185-S1D0-HS3	0.022	0.046	0.04
FM7-D220-S1D0-HS3	0.022	0.046	0.04

3.

MECHANICAL CHARACTERISTICS
Dimensions



FM7/FM9

Ref.1107

3.

MECHANICAL CHARACTERISTICS



A large grid for drawing or calculation, with a pencil icon in the top right corner.



FM7/FM9

Ref.1107

4.1 Overview

4.1.1 Motor installation

Before installing the motor, read the recommendations regarding its installation environment and install it according to them.

- ❑ Leave enough room around the motor for the air to be collected by the cooling fan integrated into the motor.
- ❑ Keep a minimum gap of 100 mm (3.94 inches) between the machine and motor cooling output.
- ❑ Install it in a clean place, away from areas with oil and water. If there is a chance for the motor to be in contact with these elements, protect it with some type of cover.



If water or dirty oil gets inside the motor, its insulation resistance may decrease causing a ground fault.

- ❑ Make sure that the motor is firmly mounted either by feet or by flange because the weight of the motor or that of the dynamic load attached to its shaft can generate vibrations when it is running.
- ❑ Install it in a place free from dust and metal particles. The motor has an integrated fan with an internal structure that supplies cooling air to the motor.



Blocking the air flow with dust particles or other strange elements can lower the efficiency of the cooling system.

- ❑ Clean the flange, the shaft and the keyway (if it has one) before installing the motor.



The flange and the motor's rotor shaft contain a layer of anti-corrosive paint or grease.

- ❑ Flange-mounted FM7 motor models may be installed with their shaft at the load end forming an angle between the horizontal and the vertical always with their shaft facing down.



The motor cannot be installed with its shaft facing up on FM7 motors.

- ❑ Foot-mounted FM7 motors must be installed with their feet secured to the floor. When mounting the motor vertically, its shaft must always be facing down.



The motor cannot be installed with its shaft facing up on FM7 motors.

4.1.2 Fan installation

All AC spindle motors of the FM7/FM9 family have an electric fan that generates a constant air flow regardless of the turning speed of the motor with a heat evacuation system. This ensures proper motor cooling in all its duty cycles.

When connecting the fan to the three-phase line, it starts turning.



WARNING. On FM7 models, make sure that the fan turns in the direction indicated on the label located on the outside of the fan housing and the direction of the air flow is the one shown in figure F. 4/1.

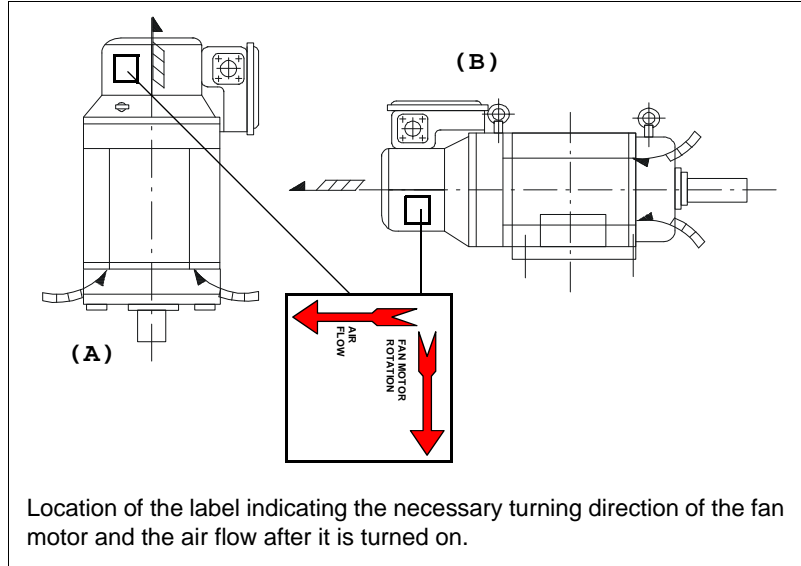

F. 4/1

Cooling air direction. Mounting: **A.** Flange, **B.** Feet.

Also take the following considerations into account:

- The air sucked by the fan must be dry, clean and cool.
- The air absorbed from the atmosphere through the conduction systems or channels for motors installed inside the structure of another machine protected by panels or other types of cover must be thrown out through the cooling hole.
- The intake of cool air and the output of hot air must be as far away from each other as possible to keep them from mixing.

4.1.3 Brake

No motor of the FM7/FM9 family has the brake option. Therefore, any sales reference MPC-4x motor-drive power cable will only have 4 wires and a shield, never 6 wires.

4.2 Connections

All the connections to be made to run the motor are made in the terminal box of the motor.



WARNING. Before removing the lid of the terminal box, make sure that both the motor and the internal fan have no voltage. Ignoring this warning may cause serious personal injury and even death.

4.2.1 Power. Motor-drive

To make this connection, first remove the lid of the terminal box by removing the screws that fix it to it.



WARNING. Before removing the lid, make sure that both the motor and the internal fan have no voltage.

Power connection of the drive with FM7 models

The connection between a motor of the FM7 family and its associated drive module must always be done using the corresponding terminals located inside the terminal box of the motor.

Two configurations are possible depending on the motor series. Hence, for E01 and E02 series motors, the stator windings must have a delta (triangle) connection and cannot be changed. It will have three terminals U, V and W plus a ground terminal to connect with the U, V, W and PE terminals on top of the drive. See figures F. 4/2 and F. 4/3.

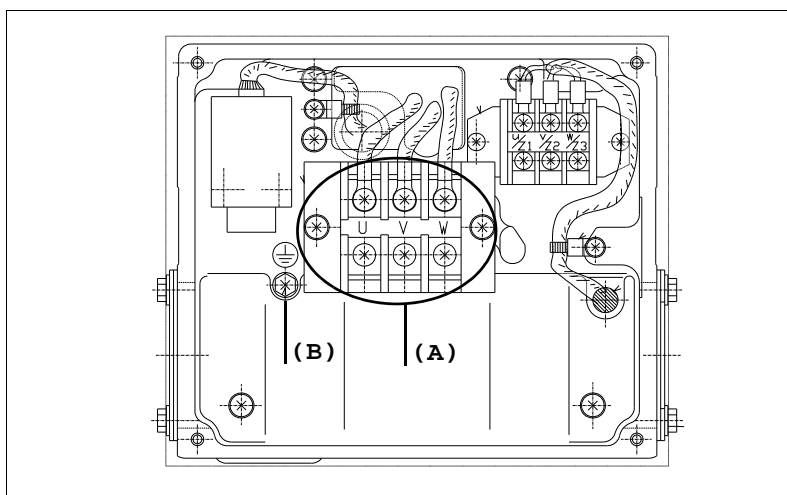

F. 4/2

Terminals to connect an FM7 motor (E01 and E02 series) to its associated drive. **A.** Power terminals U, V, W. **B.** Ground bolt.

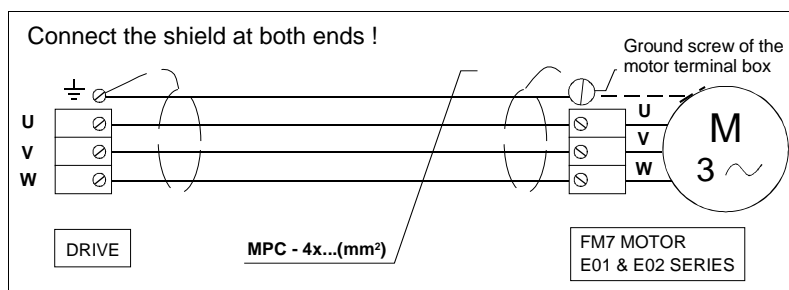

F. 4/3

Connection between the motor and the drive. FM7 family, E01 & E02 series.

4.

INSTALLATION
Connections



FM7/FM9

Ref.1107



WARNING. Remember that when connecting the drive module with its corresponding FM7 motor connect terminal U of the drive module with the terminal corresponding to the U phase of the motor. Proceed the same way with the terminals V-V, W-W and ground-ground.



IMPORTANT. In order for the system to comply with the European Directive on Electromagnetic Compatibility, the hose grouping all four unipolar cables U, V, W and ground must be shielded and must be connected at both ends, i.e. at the drive end and at the motor end.

4.

INSTALLATION
Connections

For E03 and HS3 series motors of the FM7 family, the stator windings may be configured in a Y (star) or Δ (triangle) connection. Hence, a unipolar cable is extended from each of the six terminals of the terminal box to two external magnetic contactors which will switch from one to the other type of connection through an electrical maneuver.

Observe that if the whole application needs a fixed winding configuration, make the desired winding connection (star or delta) shown in figure F. 4/4. See the diagram.

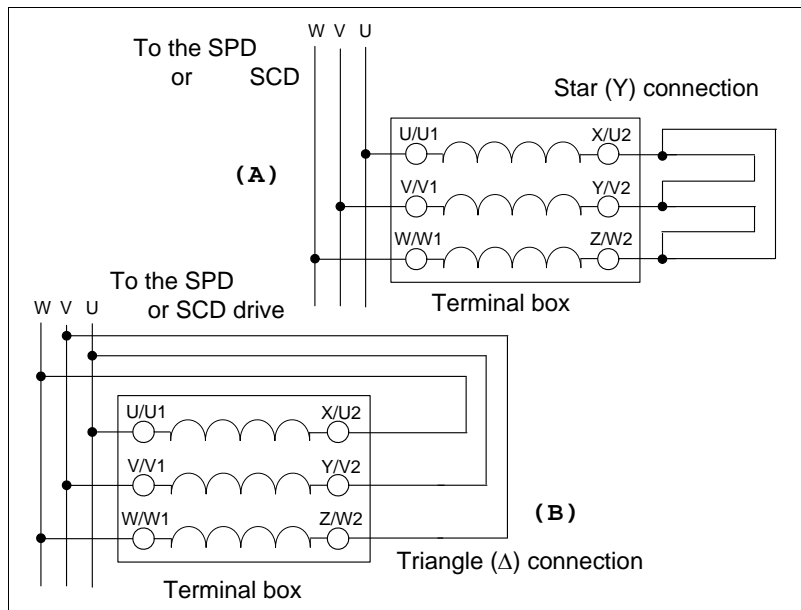

F. 4/4

Selecting the winding configuration with an electrical maneuver using two external magnetic contactors. **A.** Star (Y), **B.** Triangle (Δ).

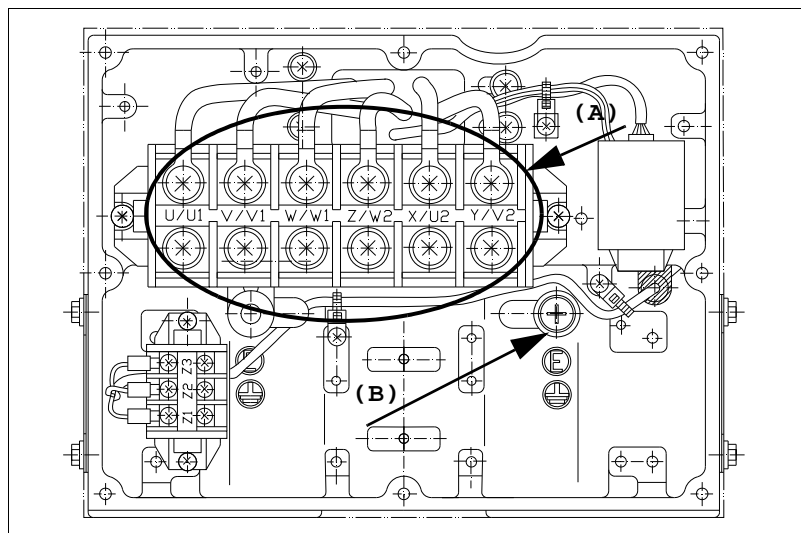

F. 4/5

Terminals to connect an FM7 motor (E03 and HS3 series) to its associated SCD drive. **A.** Power terminals U/U1, V/V1, W/W1, Z/W2, X/U2 and Y/V2. **B.** Ground bolt.



FM7/FM9

Ref.1107

The six terminals are defined by the labels U/U1, V/V1, W/W1, Z/W2, X/U2 and Y/V2. It also has a ground bolt to connect the ground cable coming from the NPC power cable hose of the drive. The three phase wires of this cable hose U, V and W must be connected to terminals U/U1, V/V1 and W/W1 of the terminal box of the motor. In turn, six cables go from these six terminals located inside the terminal box of the motor to two external magnetic contactors according to figure F. 4/12 to set the winding as star or delta.

Power connection of the drive with FM9-B055 models

The connection between an FM9-B055 motor and its associated drive module must always be done using the corresponding terminals located inside the terminal box of the motor. See figure F. 4/6.

The stator windings have a Y (star) connection. It has three terminals U, V and W plus a ground terminal to connect with the U, V, W and PE terminals on top of the drive.

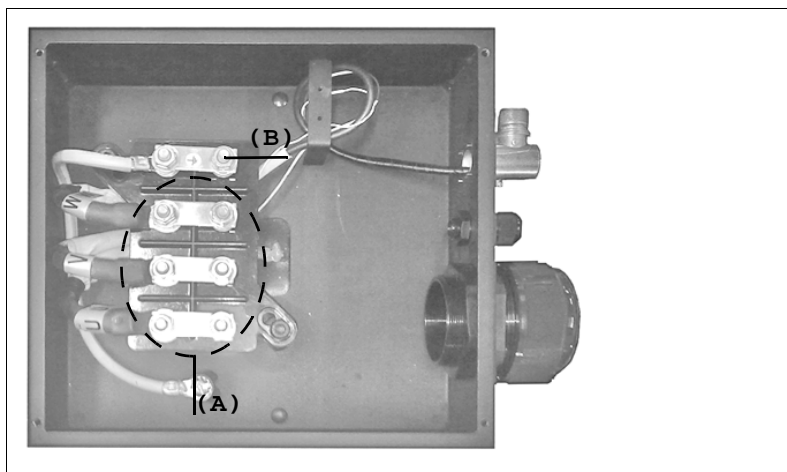

F. 4/6

Terminals to connect an FM9 motor (E01 series, B055 model) to its associated drive. A. Power terminals U, V, W. B. Ground bolt.

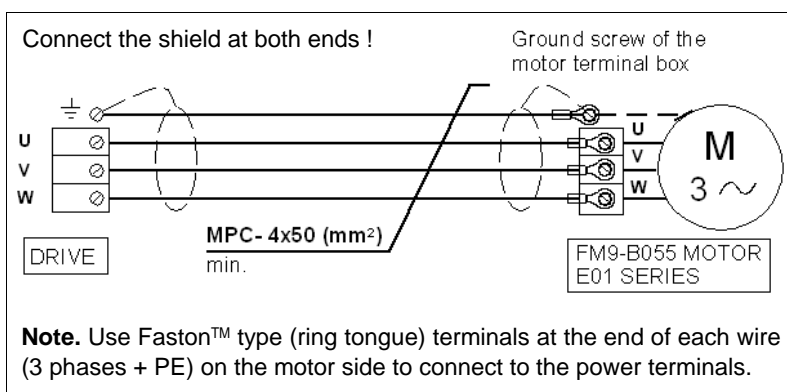

F. 4/7

Power connection between motor and drive. FM9-B055 model, E01 series.



WARNING. Remember that when connecting the drive module with its corresponding motor connect terminal U of the drive module with the terminal corresponding to the U phase of the motor. Proceed the same way with the terminals V-V, W-W and PE-PE.



IMPORTANT . In order for the system to comply with the European Directive on Electromagnetic Compatibility, the MPC-4x50 hose grouping all four unipolar cables U, V, W and PE must be shielded and must be connected at both ends, i.e. at the drive end and at the motor end.



FM7/FM9

Ref.1107

4.
INSTALLATION
Connections

Power connection of the drive with FM9-B071 models

The connection between an FM9-B071 motor and its associated drive module must always be done using the corresponding terminals placed on metal plates and located inside the terminal box of the motor. See figure **F. 4/8**.

The stator windings have a Y (star) connection. It has three terminals U, V and W plus a ground terminal to connect with the U, V, W and PE terminals on top of the drive.

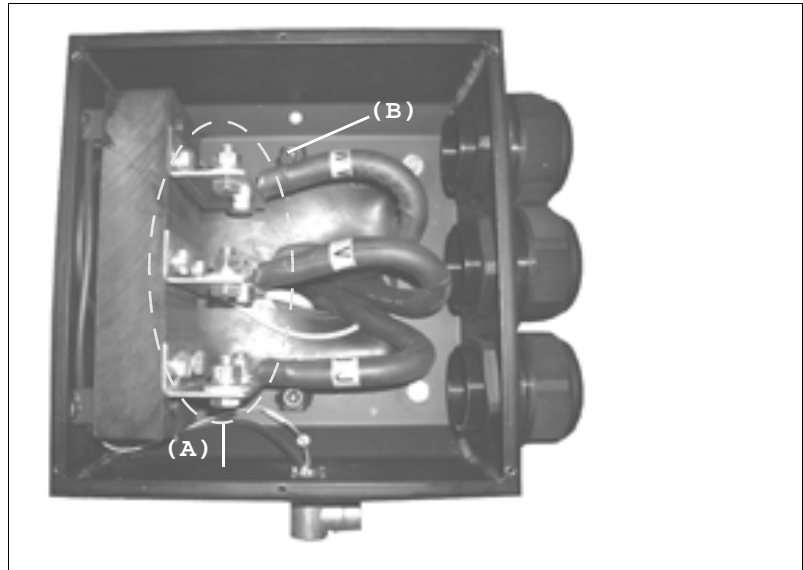

F. 4/8

Terminals to connect an FM9 motor (E01 series, B071 model) to its associated drive. **A.** Power terminals U, V, W. **B.** Ground bolt.

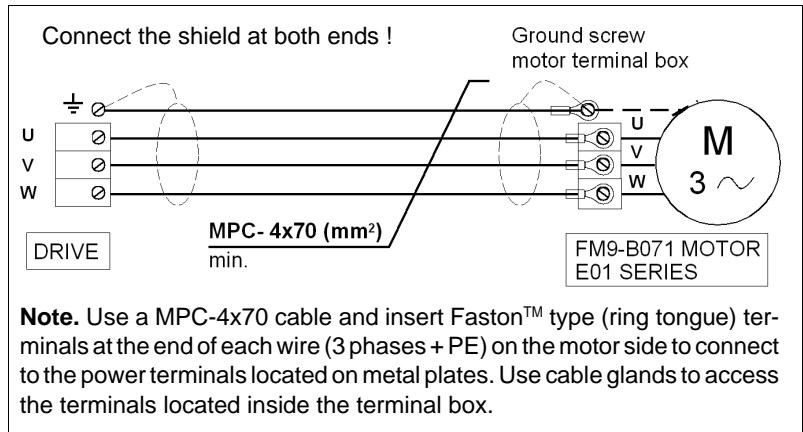

F. 4/9

Power connection between motor and drive. FM9-B071 model, E01 series.

WARNING. Remember that when connecting the drive module with its corresponding motor phase U of the MPC 4x70 cable coming from terminal U of the drive module must be connected to the terminal corresponding to phase U of the motor located on the metal plate U. Insert the Faston™ type terminal of the wire and tighten it until making contact with the **U plate** to ensure proper contact. Proceed the same way with the terminals V-V, W-W and PE-PE (at the ground screw).

IMPORTANT . In order for the system to comply with the European Directive on Electromagnetic Compatibility, the MPC-4x70 hose grouping all four unipolar cables U, V, W and PE must be shielded and must be connected at both ends, i.e. at the drive end and at the motor end.



FM7/FM9

Ref.1107

Power connection of the drive with models FM9-A100, FM9-B113 and FM9-A130

The connection between FM9-A100, FM9-B113 and FM9-A130 motors and their associated drive module must always be done using the corresponding terminals placed on metal plates and located inside the terminal box of the motor. See figure F. 4/10.

The stator windings have a Y (star) connection. It has three terminals U, V and W plus a ground terminal to connect with the U, V, W and PE terminals on top of the drive.

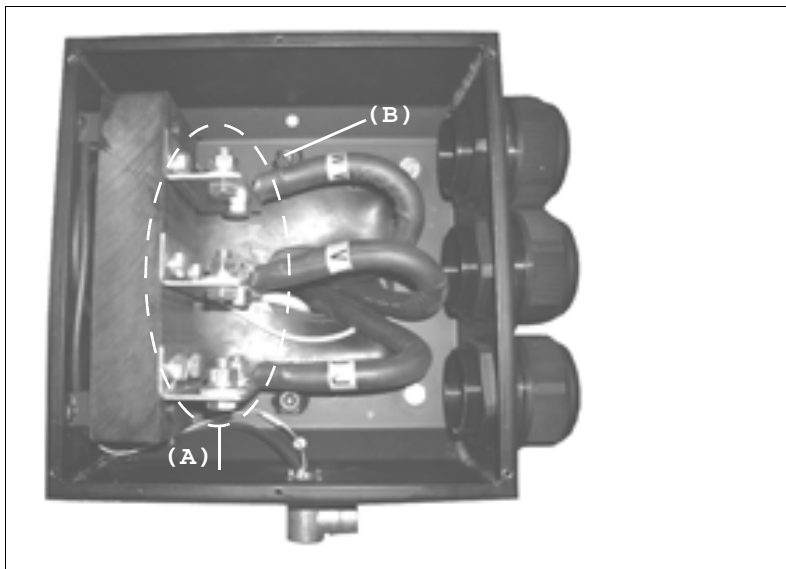

F. 4/10

Terminals to connect an FM9 motor (E01 series, A100, B113 and A130 model) to its associated drive. **A.** Power terminals U, V, W. **B.** Ground bolt.

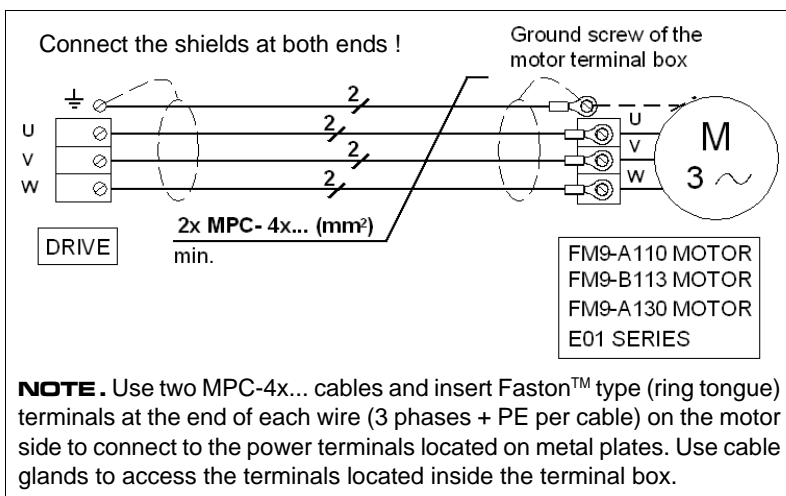

F. 4/11

Power connection between motor and drive. Models FM9-A100, FM9-B113 and FM9-A130, E01 series.



WARNING . Remember that when connecting the drive module with its corresponding motor phase U of each MPC 4x... cable coming from terminal U of the drive module must be connected to the terminal corresponding to phase U of the motor located on the metal plate U. Insert the Faston™ type terminal of each wire, **one on each side of the U plate** and tighten it to ensure proper contact. Proceed the same way with the terminals V-V, W-W and PE-PE (at the ground screw).

4.

INSTALLATION
Connections



FM7/FM9

Ref.1107



IMPORTANT . In order for the system to comply with the European Directive on Electromagnetic Compatibility, each of the two MPC-4x... hoses grouping all four unipolar cables U, V, W and PE must be shielded and must be connected at both ends, i.e. at the drive end and at the motor end.

If the user has difficulty locating the terminals of the drive's power connector, see chapter drive modules of the corresponding servo drive manual.

4.

INSTALLATION
Connections

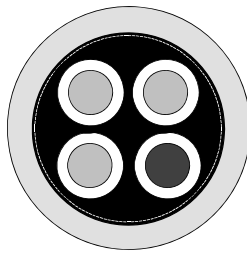

Power cabling

According to the EN 60204-1 regulation to be applied to servo system installations, the range of power cables offered by Fagor Automation for these motors are:

T. 4/1 Range of power cables. MPC- 4x□.

Ref. MPC - Nr of cables x section of each wire in mm ² Dmax. corresponds to outside diameter of the cable in mm.			
Ref.	Dmax	Ref.	Dmax
MPC-4x2.5	11.6 mm	MPC-4x25	28.7 mm
MPC-4x4	13.1 mm	MPC-4x35	34.0 mm
MPC-4x6	15.3 mm	MPC-4x50	40.1 mm
MPC-4x10	19.2 mm	MPC- 4x70	42.1 mm
MPC-4x16	24.5 mm		

Mechanical characteristics

T. 4/2 Mechanical characteristics of the power cable MPC-4x□.

Type	Shield. It ensures EMC Compatibility.
Flexibility	High. Special to be used in cable carrying chains with a bending radius of 10 times the Dmax under dynamic conditions and 6 times the Dmax under static conditions.
Covering	PUR. Polyurethane immune to the chemical agents used in machine tools.
Temperature	Work: -20°C to +60°C (-4°F to +140°F) Storage: -50°C to +80°C (-58°F to +176°F)
Rated voltages	Uo/U: 600/1000 V.

Power cable section selection

T. 4/3 Selection of the section of a unipolar unshielded cable in a three-phase configuration depending on the current I S1.

FM7-□□□□-□□□□-E01/E02		
Motor model	In (S1) Arms	Ref. of the power cable
FM7-A037-□□□□-E01/E02	12.5	MPC-4x2.5
FM7-A055-□□□□-E01/E02	14.6	MPC-4x2.5
FM7-A075-□□□□-E01/E02	19.8	MPC-4x4
FM7-A090-□□□□-E01/E02	25.0	MPC-4x6
FM7-A110-□□□□-E01/E02	28.0	MPC-4x6
FM7-A150-□□□□-E01/E02	39.4	MPC-4x10
FM7-A185-□□□□-E01/E02	47.5	MPC-4x16
FM7-A220-□□□□-E01/E02	61.4	MPC-4x25
FM7-B120-□□□□-E01/E02	35.0	MPC-4x10
FM7-B170-□□□□-E01/E02	47.3	MPC-4x16
FM7-A300-□□□□-E01	82.1	MPC-4x35
FM7-B220-□□□□-E01	64.9	MPC-4x25
FM7-A370-□□□□-E01	90.0	MPC-4x50
FM7-B280-□□□□-E01	78.2	MPC-4x35
FM7-A510-□□□□-E01/E02	115.2	MPC-4x70
FM7-C215-□□□□-E01/E02	87.9	MPC-4x50



FM7/FM9

Ref.1107

T. 4/3 Selection of the section of a unipolar unshielded cable in a three-phase configuration depending on the current I S1.

Motor model	In (S1) Arms	Ref. of the power cable
FM7-C270-□□□□-E01/E02	117.0	MPC-4x70
FM7-E600-C□B□-E01	117.4	MPC-4x70

T. 4/4 Selection of the section of a unipolar unshielded cable in a three-phase configuration depending on the current I S1.

FM7-D□□□-S1D0-E03/HS3		
Motor model	In (S1) Arms ▲/△	Ref. of the power cable
FM7-D055-S1D0-E03	20.3 / 20.7	MPC-4x4
FM7-D075-S1D0-E03	26.5 / 25.8	MPC-4x6
FM7-D110-S1D0-E03	38.0 / 40.0	MPC-4x10
FM7-D150-S1D0-E03	46.4 / 45.7	MPC-4x16
FM7-D185-S1D0-E03	49.2 / 49.2	MPC-4x16
FM7-D220-S1D0-E03	62.3 / 61.7	MPC-4x25
FM7-D075-S1D0-HS3	26.5 / 25.8	MPC-4x6
FM7-D110-S1D0-HS3	38.0 / 40.0	MPC-4x10
FM7-D185-S1D0-HS3	49.2 / 49.2	MPC-4x16
FM7-D220-S1D0-HS3	62.3 / 61.7	MPC-4x25

T. 4/5 Selection of the section of a unipolar unshielded cable in a three-phase configuration depending on Inominal.

FM9-□□□□-C5C□-E01		
Motor model	In (S1) Arms	Ref. of the power cable
FM9-B055-C5C□-E01	104.4	MPC-4x50*
FM9-B071-C5C□-E01	134.8	MPC-4x70*
FM9-A100-C5C□-E01	189.9	2x MPC-4x50
FM9-B113-C5C□-E01	214.6	2x MPC-4x70
FM9-A130-C5C□-E01	246.9	2x MPC-4x70

(*) Note that the sections given for three-phase lines in a PVC hose shown in this table may be installed on a machine through conduits or channels except those shown in bold letters. When installed under other more / less favorable conditions, some sections may be reduced/enlarged according to the EN-60204-1 standard.



Also note that all the references of the power cables for the FM7/FM9 motors always have 4 wires. They will never have 6 wires because these motors do not have a brake.

Diagram for the electrical maneuver of the on-the-fly Y-Δ switching winding

4.
INSTALLATION
Connections

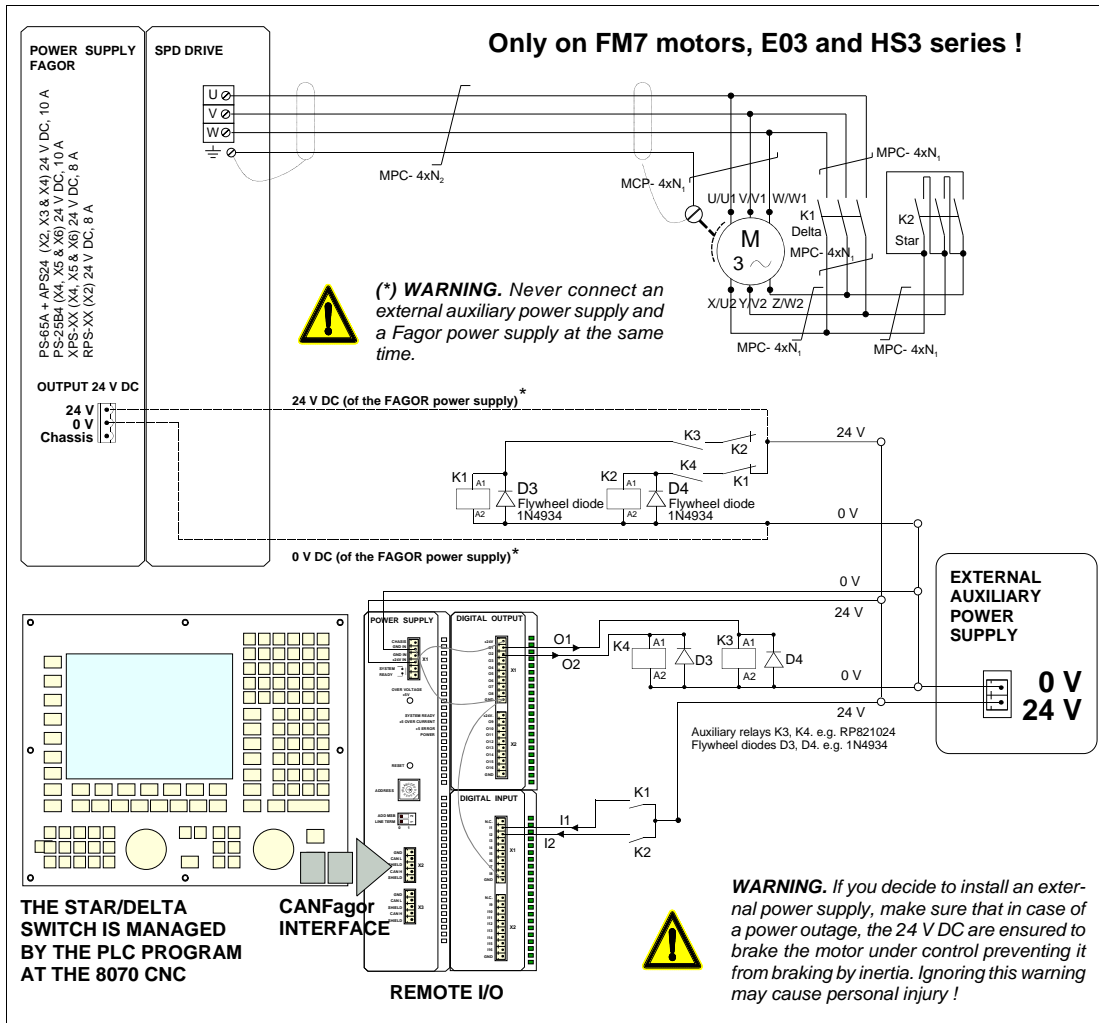

F. 4/12

Connection between the motor and the drive. FM7 family, E03 and HS3 series. Diagram for the on-the-fly Y-Δ switching of the winding configuration.

Important warnings

- ❑ Either an external auxiliary power supply or a FAGOR power supply may be used to supply the 24 V DC. NEVER CONNECT BOTH AT THE SAME TIME !
- ❑ To brake the motor in a controlled way during a power failure, make sure that 24 V DC will be supplied to contactors K1 and K2 and relays K3 and K4. This situation is ensured if you have installed a FAGOR power supply next to an SPD modular drive. If you have installed an external auxiliary 24 V DC power supply, you must make sure that this condition is ensured.
- ❑ When using a compact SCD drive to govern a spindle motor, you must necessarily install an external auxiliary power supply to provide the 24 V DC. These compact drives do not have an output 24 V DC connector.
- ❑ Always join all the GND of different remote I/O modules together. The GND of the same module are already connected to each other internally.
- ❑ It is better to power the POWER SUPPLY module with an external auxiliary power supply and the DIGITAL OUTPUT module with another one. If there is only one external auxiliary power supply, always join its 24 V DC with the 24 V DC of the POWER SUPPLY module and of each module.

Sizing of power contactors K1 and K2

Contactor K1: $I_{(K1)} \geq I_N (\Delta)$
Contactor K2: $I_{(K2)} \geq (1/\sqrt{3}) I_N (\Delta)$

Note. See the rated currents in the selection chapter of this manual.

Sizing of motor power cables

MPC- 4xN₁ → N₁: section supporting I_N (Δ)
MPC- 4xN₂ → N₂: section supporting I_N (Δ)

Note. See the necessary cable section in the corresponding section of this chapter.



FM7/FM9

Ref.1107

4.2.2 Feedback. Motor-drive

Connecting the feedback to the drive on FM7 models

The connection between the motor feedback and its associated drive module must always be done using the connector located inside the terminal box and drive connector X4. See figure F. 4/13 that shows the location of the feedback connector on the motor.

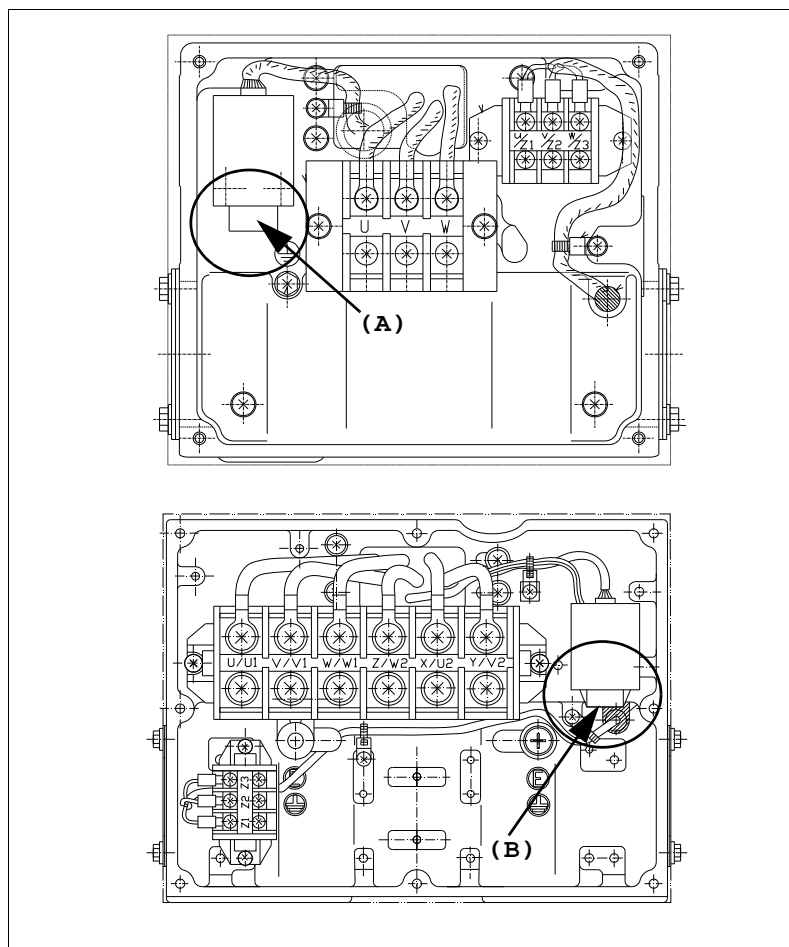

F. 4/13

Motor feedback connector of the FM7 family motors.

A. Motor feedback connector of the E01 and E02 series.

B. Motor feedback connector of the E03 and HS3 series.

The motor feedback connector is different depending on the type of encoder that the motor has. Hence:

T. 4/6 Encoders available for each motor series of the FM7 family.

Motor series	Type of encoder	
	Estándar, ● = S	Optional, ● = C
FM7-□□□□-●□□□-E01 *	Magnetic TTL	C axis. 1Vpp sinusoidal SinCos™
FM7-□□□□-●□□□-E02	Magnetic TTL	C axis. 1Vpp sinusoidal SinCos™
FM7-D□□□-●1D0 -E03	Magnetic TTL	---
FM7-D□□□-●1D0-HS3	Magnetic TTL	---

*FM7-E600-C□B□-E01 motors only have the C axis encoder option. The standard "magnetic TTL encoder" option is not available for these models.

Motor feedback base connector

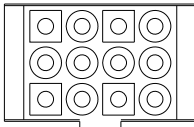

12	11	10	9
8	7	6	5
4	3	2	1

Connector ELR-12V

Pinout of the magnetic TTL encoder connector

Any motor series of the FM7 family from Fagor Automation having an integrated magnetic TTL encoder (standard feedback) carries an ELR-12V connector in its terminal box. Looking at this connector from the fan side, the pinout is:

1	+ 5 Volt	7	PCC
2	0 Volts	8	★PCC
3	PCA	9	Not connected
4	★PCA	10	SS (shield)
5	PCB	11	THSA (thermistor NTC)
6	★PCB	12	THSB (thermistor NTC)

Note. The ELR-12V connector comes already in the terminal box of the motor. It will be used to connect the feedback cable.

Magnetic TTL encoder connecting cables

The connection between the magnetic TTL encoder and the drive module must be made using one of the following cables:

T. 4/7 Range of motor feedback cables when using a magnetic TTL encoder.

References	Description
EEC-FM7	Cable with overall shield.
EEC-FM7S (type I)	Cable with overall shield and shielded twisted pairs.
EEC-FM7S (type II)	Same as type I. Their wire colors are different.

Note. Observe that using an EEC-FM7S cable instead of an EEC-FM7 cable improves its flexibility and system immunity against disturbances.

EEC-FM7 cable diagram

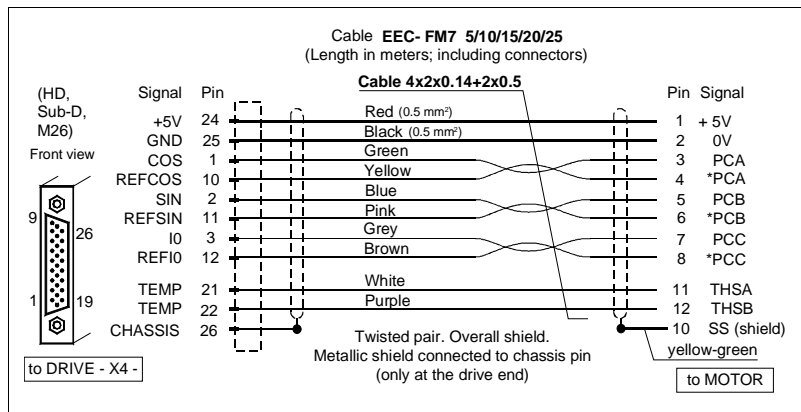

F. 4/14

EEC-FM7 connection cable between the motor with magnetic TTL encoder and the drive.

Important. Pin 9 of connector ELP-12V does not receive any wire; i.e. the wire will not be crimped at this pin.

NOTE . There is no connector at the motor end of this cable. The user must insert the pins and mount the connector at this end before connecting it. All these elements are supplied by Fagor packed in a bag inside the terminal box.



FM7/FM9

Ref.1107

Sales reference and code

T. 4/8 Sales references and codes of the EEC-FM7 cable.

Reference	Service	Reference	Service
EEC-FM7-5	04081010	EEC-FM7-20	04081013
EEC-FM7-10	04081011	EEC-FM7-25	04081014
EEC-FM7-15	04081012		

Mechanical characteristics

T. 4/9 Mechanical characteristics of the motor feedback cable. EEC-FM7.

Type	Shielded and with twisted pairs.
Approx. Dmax	8.5 mm
Flexibility	High. Special for controlling servo drives, with a minimum bending radius, when working, of 20 times its diameter Dmax (170 mm).
Covering	PUR. Polyurethane immune to the chemical agents used in machine tools.
Temperature	Work: -20°C to +70°C (- 4°F to +158°F) Storage: -40°C to +80°C (-40°F to +176°F)
Rated voltage	U: 150 V.

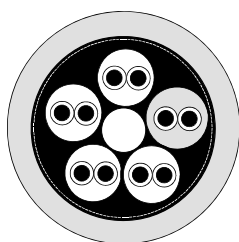

EEC-FM7S cable diagram

When having an EEC-FM7S cable to connect the motor feedback to the drive, it must be borne in mind that for the same sales reference there are two cables hoses with identical characteristics but with different color wires depending on the manufacturer of the cable. Hence, we will refer to type I and type II to point out this difference.

IMPORTANT . When using an EEC-FM7S cable, first verify whether it is a type I or a type II. A quick way to check this is to see **if it has an orange wire**. If so, it is a **type II** cable; otherwise, it is a type I. Once it has been identified, mount the motor end of the cable according to the diagram for the type that has been identified. See the diagrams later on.



Note that both cable hose types I and II mentioned next are the same in terms of pin-to-pin connection. Their only difference is the color of some of their wires because they are supplied by different manufacturers. The name of "cable hose" refers to a cable without connectors shown in the connection diagrams. According to these diagrams, the user must check which type matches the colors of the cable he is about to install.

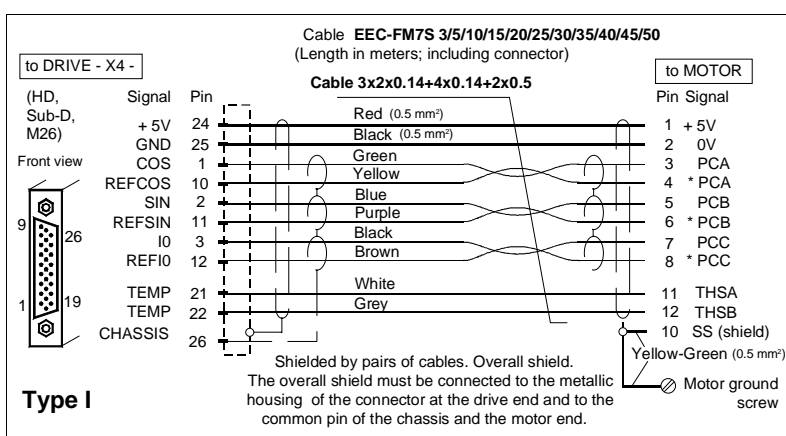

F. 4/15

EEC-FM7S (type I) connection cable between the magnetic TTL encoder of the motor and the drive.



FM7/FM9

Ref.1107

4.
INSTALLATION
Connections

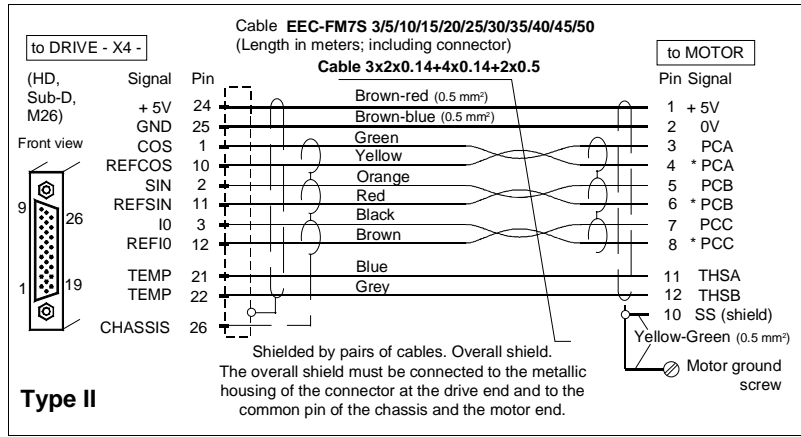

F. 4/16

EEC-FM7S (type II) connection cable between the motor with magnetic TTL encoder and the drive.

IMPORTANT . Pin 9 of connector ELP-12V does not receive any wire; i.e. the wire will not be crimped at this pin.

NOTE . There is no connector at the motor end of this cable. The user must insert the pins and mount the connector at this end before connecting it. All these elements are supplied by Fagor packed in a bag inside the terminal box.

Sales reference and code

T. 4/10 Sales references and codes of the EEC-FM7S cable.

Reference	Service	Reference	Service
EEC-FM7S-3	04080027	EEC-FM7S-30	04081020
EEC-FM7S-5	04081000	EEC-FM7S-35	04081021
EEC-FM7S-10	04081001	EEC-FM7S-40	04081022
EEC-FM7S-15	04081002	EEC-FM7S-45	04081023
EEC-FM7S-20	04081003	EEC-FM7S-50	04081024
EEC-FM7S-25	04081004		

Mechanical characteristics

T. 4/11 Mechanical characteristics of the motor feedback cable. EEC-FM7S.

Type	Shielded and with shielded twisted pairs.
Approx. Dmax	8.5 mm.
Flexibility	High. Special for controlling servo drives, with a minimum bending radius, when working, of 12 times its diameter Dmax (102 mm).
Covering	PUR. Polyurethane immune to the chemical agents used in machine tools.
Temperature	Work: 0°C to +80°C (+32°F to +176°F) Storage: - 40°C to 80°C (- 40°F to +176°F)
Rated voltage	U: 250 V.

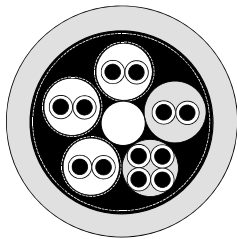

FM7/FM9



Please read this section very carefully !

Ref.1107

Mounting the EEC-FM7 / EEC-FM7S cable

The feedback cable has unconnected wires at the motor end. The user must mount the connector following the indicated procedure:

- Remove the four M5x12 bolts located at the 4 corners of the top of the terminal box of the motor and open the lid to access to the accessories bag.
- Unpack the bag supplied by Fagor containing 11 pins SLF-01T and the body of connector ELP-12V.

WARNING . Do not insert the body of the connector ELP-12V supplied as accessory into connector ERL-12V of the terminal box without previously making the connection cable.

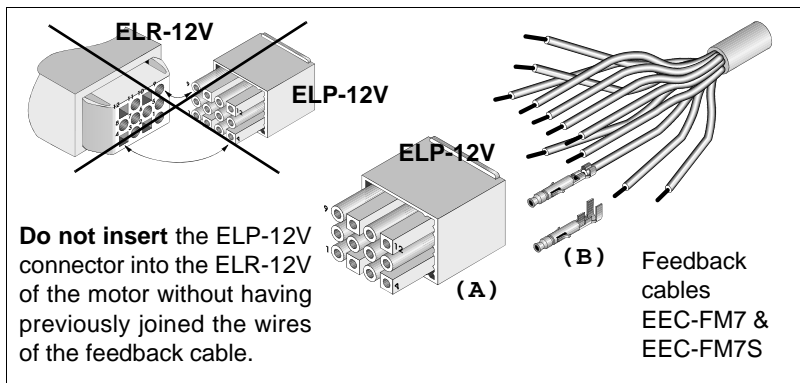

F. 4/17

Mounting the EEC-FM7 or EEC-FM7S cable. Accessories: **A.** Body of connector ELP-12V. **B.** SLF-01T pins.

- Crimp the end of each wire with each SLF-01T pin.

IMPORTANT. Be careful with the wires being crimped with each terminal because there are 11 pins and 12 wires. One of them must not be connected and therefore will not have a pin to be crimped. See the cable diagram to know which wire it is and be careful with the colors.

- Insert each wire end already crimped into its corresponding pin of the body of connector ELP-12V supplied as accessory.

IMPORTANT. Make sure that each pin is inserted into the corresponding pin of connector ELP-12V. If the user makes a mistake, it is difficult to recover the pin in its best shape. Carefully follow the connection diagram and the numbering of pins of connector ELP-12V. The tab marked with a circle in figure **F. 4/18** must be at the bottom when making the connection.

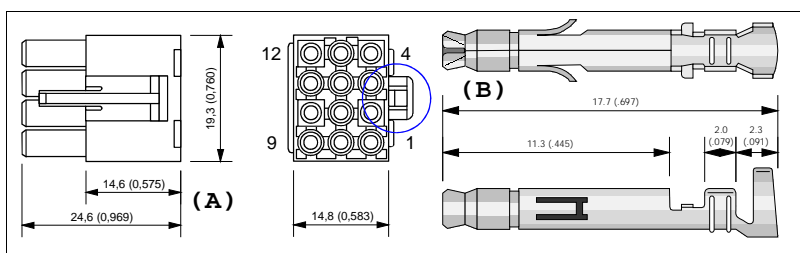

F. 4/18

Accessories: **A.** Body of connector ELP-12V. **B.** SLF-01T pins.

- Insert the body of the connector ELP-12V already attached to the feedback cable into the socket of connector ERL-12V of the terminal box to make the connection with the feedback device.

Make sure that the tab at the bottom of the body of the connector ELP-12V clicks when connecting it. This click ensures that it has been inserted properly.



FM7/FM9

Ref.1107

4.
INSTALLATION
Connections

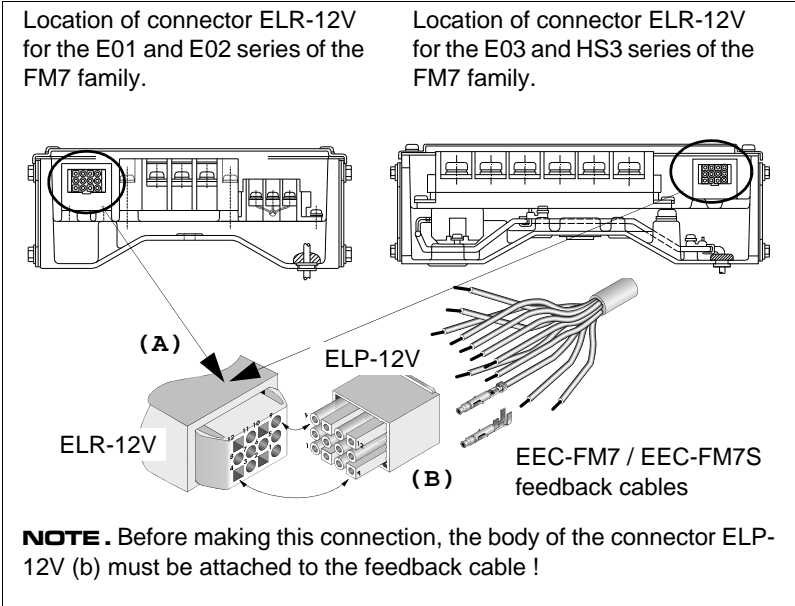

F. 4/19

A. Connector ELR-12V. B. Body of connector ELP-12V.



WARNING . When having to extract the body of the connector ELP-12V from the socket of the connector of the encoder ELR-12V, make sure that the motor is not powered, push the tab at the bottom (not visible) up and pull it. Never pull the cable because it could damage it !

Motor feedback base connector

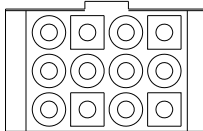

1	2	3	4
5	6	7	8
9	10	11	12

Connector ELR-12V

Pinout of the C axis encoder connector

Any motor series of the FM7 family from Fagor Automation having an integrated C axis SinCos™ encoder (optional feedback) carries an ELR-12V connector in its terminal box. Looking at this connector from the fan side, the pinout is:

1	+ 8 Volt	7	+ 485
2	0 Volts	8	- 485
3	SIN	9	SS (shield)
4	REFSIN	10	Not connected
5	COS	11	THSA (thermistor NTC)
6	REFCOS	12	THSB (thermistor NTC)

NOTE . The ELR-12V connector comes already in the terminal box of the motor and it is rotated 180° with respect to that of the magnetic TTL encoder (standard). It will be used to connect the feedback cable.

C axis SinCos™ encoder connecting cables

The connection between the C axis SinCos™ encoder and the drive module must be made using one of the following cables:

T. 4/12 Range of motor feedback cables when using a C axis encoder.

References	Description
EEC-FM7CS (type I)	Cable with overall shield & shielded twisted pairs.
EEC-FM7CS (type II)	Same as type I. Their wire colors are different.



FM7/FM9

Ref.1107

EEC-FM7CS cable diagram

When having an EEC-FM7CS cable to connect the motor feedback to the drive, it must be borne in mind that for the same sales reference there are two cables hoses with identical characteristics but with different color wires depending on the manufacturer of the cable. Hence, we will refer to type I and type II to point out this difference.

IMPORTANT . When using an EEC-FM7CS cable, first verify whether it is a type I or a type II. A quick way to check this is to see **if it has an orange wire**. If so, it is a **type II** cable; otherwise, it is a type I. Once it has been identified as type I or type II, mount the motor end of the cable according to the diagram for the type that has been identified.



Note that both cable hose types I and II mentioned next are the same in terms of pin-to-pin connection. Their only difference is the color of some of their wires because they are supplied by different manufacturers. The name of "cable hose" refers to a cable without connectors shown in the connection diagrams. According to these diagrams, the user must check which type matches the colors of the cable he is about to install.

4.
INSTALLATION
Connections

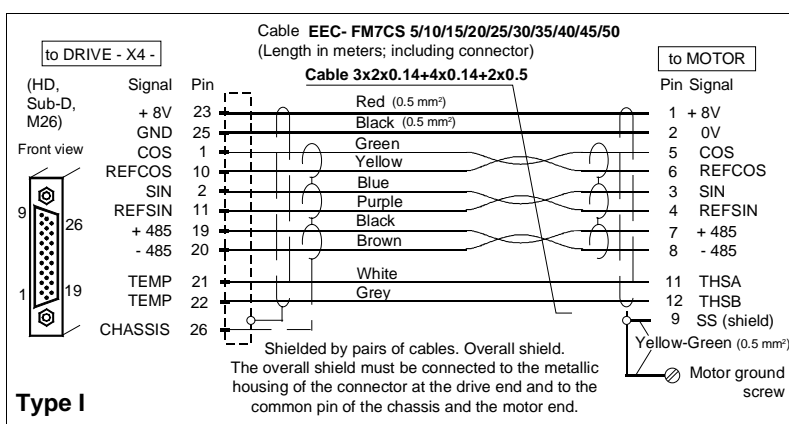

F. 4/20

EEC-FM7CS (type I) connection cable between the motor with C axis encoder and the drive.

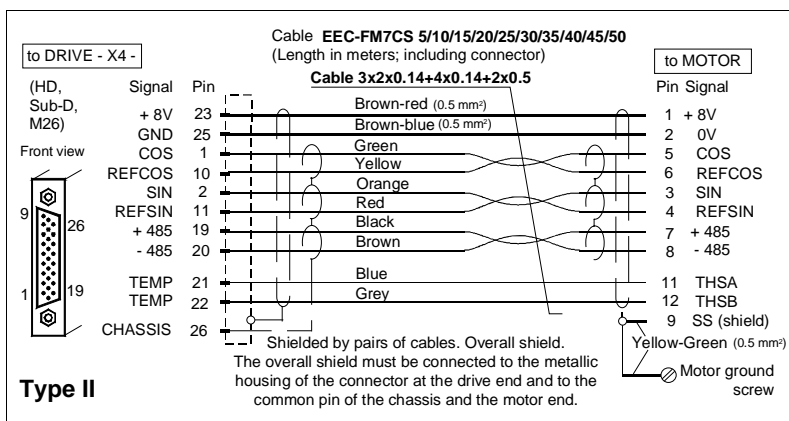

F. 4/21

EEC-FM7CS (type II) connection cable between the motor with C axis encoder and the drive.

IMPORTANT . Pin 10 of connector ELP-12V does not receive any wire; i.e. the wire will not be crimped at this pin.

NOTE . There is no connector at the motor end of this cable. The user must insert the pins and mount the connector at this end before connecting it. All these elements are supplied by Fagor packed in a bag inside the terminal box.



FM7/FM9

Ref.1107

4.
INSTALLATION
Connections

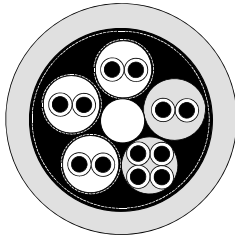

Mechanical characteristics

T. 4/13 Mechanical characteristics of the motor feedback cable. EEC-FM7CS.

Type	Shielded and with shielded twisted pairs.
Approx. Dmax	8.5 mm
Flexibility	High. Special for controlling servo drives, with a minimum bending radius, when working, of 12 times its diameter Dmax (102 mm).
Covering	PUR. Polyurethane immune to the chemical agents used in machine tools.
Temperature	Work: 0°C to +80°C (+32°F to +176°F) Storage: -40°C to +80°C (-40°F to +176°F)
Rated voltage	U: 250 V.

Assembling the EEC-FM7CS cable



Please read this section very carefully !

The feedback cable has unconnected wires at the motor end. The user must mount the connector following the indicated procedure:

- Remove the four M5x12 bolts located at the 4 corners of the top of the terminal box of the motor and open the lid to access to the accessories bag.
- Unpack the bag supplied by Fagor containing 11 pins SLF-01T and the body of connector ELP-12V.

WARNING . Do not insert the body of the connector ELP-12V supplied as accessory into connector ERL-12V of the terminal box without previously making the connection cable.

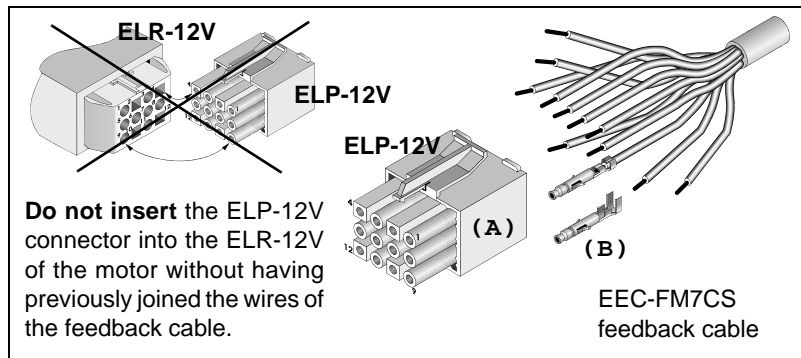

F- 4.22

Assembling the EEC-FM7CS cable.

Accessories: **A.** Body of connector ELP-12V. **B.** SLF-01T pins.

- Crimp the end of each wire with each SLF-01T pin.

Be careful with the wires being crimped with each terminal because there are 11 pins and 12 wires. One of them must not be connected and therefore will not have a pin to be crimped. See the cable diagram to know which wire it is and be careful with the colors.

- Insert each wire end already crimped into its corresponding pin of the body of connector ELP-12V supplied as accessory.

IMPORTANT . Make sure that each pin is inserted into the corresponding pin of connector ELP-12V. If the user makes a mistake, it is difficult to recover the pin in its best shape. Carefully follow the connection diagram and the numbering of pins of connector ELP-12V. The tab marked with a circle in figure **F. 4/23** must be at the top when making the connection.



FM7/FM9

Ref.1107

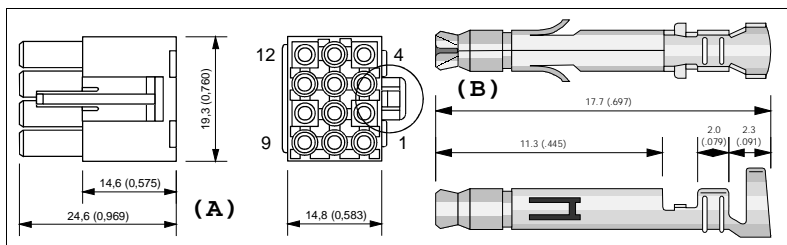

F. 4/23

Accessories: **A.** Body of connector ELP-12V. **B.** SLF-01T pins.

- Insert the body of the connector ELP-12V already attached to the feedback cable into the socket of connector ERL-12V of the terminal box to make the connection with the feedback device.

Make sure that the tab at the top of the body of the connector ELP-12V clicks when connecting it. This click ensures that it has been inserted properly.

Location of connector ELR-12V for the E01 and E02 series of the FM7 family.

Location of connector ELR-12V for the E03 and HS3 series of the FM7 family.

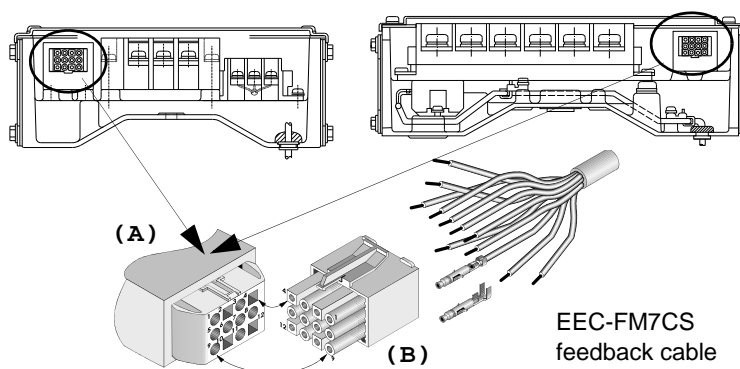

NOTE. Before making this connection, the body of the connector ELP-12V (B) must be attached to the feedback cable !

F. 4/24

A. Connector ELR-12V. **B.** Body of connector ELP-12V.



WARNING. When having to extract the body of connector ELP-12V from the housing of the connector of the ELR-12V encoder, make sure that the motor is without power. Press the tab on the top (not visible) down and pull at it. Never pull the cable because it could damage it.

4.
INSTALLATION
Connections

Connecting the feedback to the drive on FM9 models

The connection between the motor feedback and its associated drive module must always be done using the connector located outside the terminal box and the connector of the motor feedback at the drive. See figure F. 4/25 that shows the location of the feedback connector on the motor depending on model.

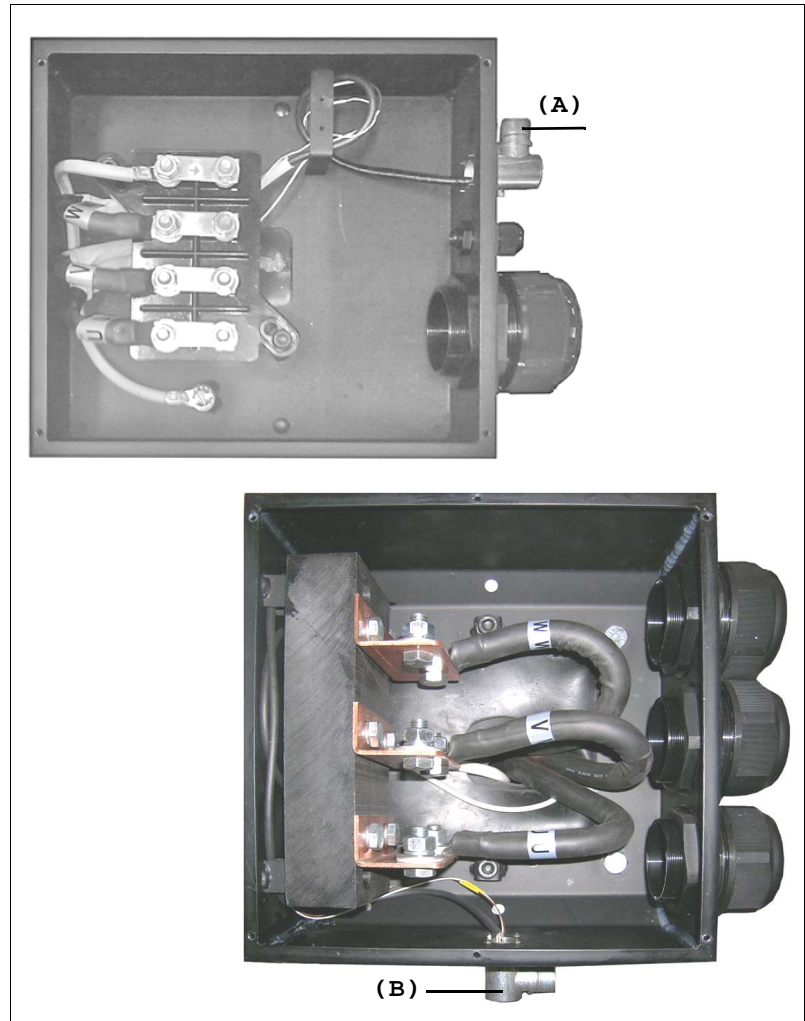

F. 4/25

Motor feedback connector of the FM9 family motors.

A. Motor feedback connector on B055 model.

B. Motor feedback connector on B071, A100, B113, A130 models.

Available encoders

T. 4/14 Encoders available for FM9 motors.

Motor series	Type of encoder
	Estándar, ● = C
FM9-□□□□-●□□□-E01	C axis. 1 Vpp sinusoidal SinCos™ encoder. 1024 ppt



FM7/FM9

Ref.1107

Motor feedback base connector

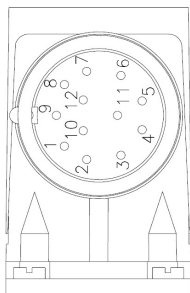

EOC 12 connector

Pinout of the connector of the C axis SinCos™ encoder

Any motor series of the FM9 family from Fagor Automation having an integrated C axis SinCos™ encoder (optional feedback) carries an EOC-12 base connector in its terminal box. Looking at this connector, the pinout is:

1	REFCOS	7	- 485
2	+ 485	8	COS
3	KTY84 -	9	SS (shield) + CHASSIS
4	KTY84 +	10	GND
5	SIN	11	N. C. (not connected)
6	REFSIN	12	+ 8 V DC

C axis SinCos™ encoder connecting cables

The connection between the C axis SinCos™ encoder and the drive module must be made using one of the following cables. Note that the motor feedback will be wired differently depending on the drive model it will be connected to.

T. 4/15 Range of motor feedback cables when using a C axis SinCos™ encoder.

Drive model	Cable reference	Description
SPD series	EEC o	Cable with overall shield or
	EEC - SP (see note further below)	Cable with overall shield and shielded twisted pairs
CT series	EEC-SP + CA-EEC-CT	Cable with overall shield and shielded twisted pairs + adapter cable

NOTE. Observe that using an EEC-SP cable instead of an EEC cable improves its flexibility and system immunity against disturbances.

EEC cable diagram

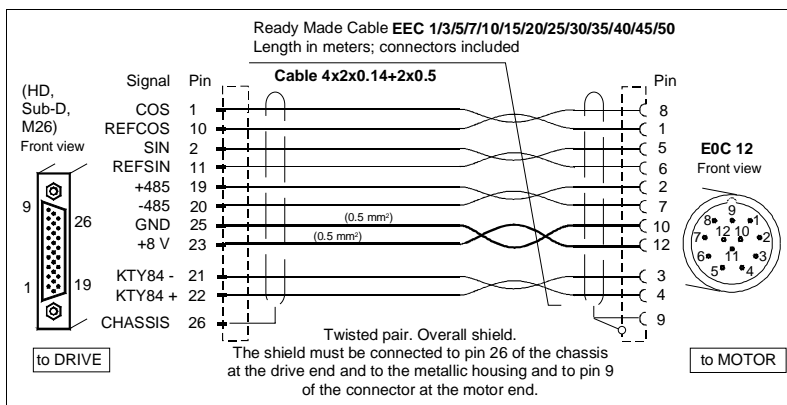

F. 4/26

EEC connection cable between the motor with C axis SinCos™ encoder and the drive.

Sales reference and code

T. 4/16 Sales references and codes of the EEC cable.

Reference	Service	Reference	Service
EEC-1	04080001	EEC-25	04080007
EEC-3	04080025	EEC-30	04080050
EEC-5	04080003	EEC-35	04080051
EEC-7	04080026	EEC-40	04080052
EEC-10	04080004	EEC-45	04080053
EEC-15	04080005	EEC-50	04080054
EEC-20	04080006		



FM7/FM9

Ref.1107

4.
INSTALLATION
Connections

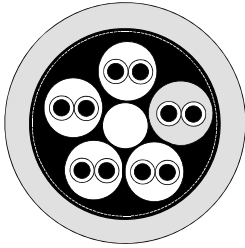

Mechanical characteristics

T. 4/17 Mechanical characteristics of the motor feedback cable. EEC.

Type	Overall shield. Unshielded twisted pairs
Approx. Dmax	8.5 mm
Flexibility	High. Special for controlling servo drives, with a minimum bending radius under dynamic conditions (when flexed) of 20 times the Dmax. (= 170 mm).
Covering	PUR. Polyurethane immune to the chemical agents used in machine tools.
Temperature	Work: -20°C/+70°C (- 4°F/+158°F) Storage: -40°C / +80°C (-40°F / +176°F)
Work voltage	U: 150 V.

EEC-SP cable diagram

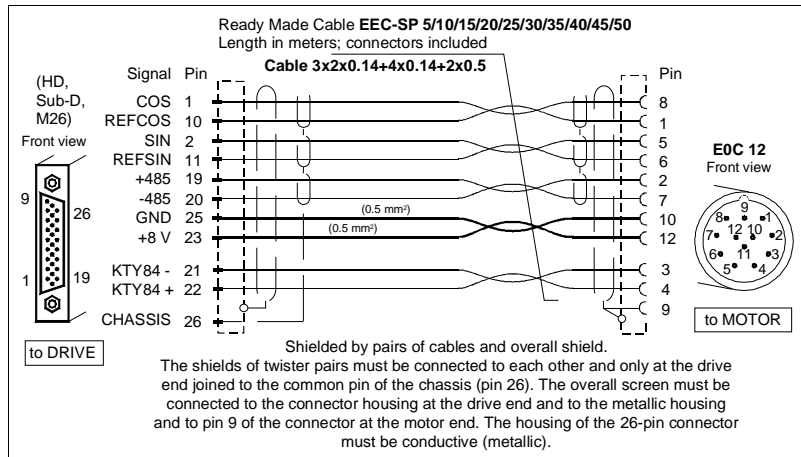

F. 4/27

EEC-SP motor connection cable with a C axis SinCos™ encoder directly to the drive (SPD series) or indirectly to the drive (through a CA-EEC-CT adapter).

Sales reference and code

T. 4/18 Sales references and codes of the EEC-SP cable.

Reference	Service	Reference	Service
EEC-SP-5	04080020	EEC-SP-30	04080060
EEC-SP-10	04080021	EEC-SP-35	04080061
EEC-SP-15	04080022	EEC-SP-40	04080062
EEC-SP-20	04080023	EEC-SP-45	04080063
EEC-SP-25	04080024	EEC-SP-50	04080064

Mechanical characteristics

T. 4/19 Mechanical characteristics of the motor feedback cable. EEC-SP.

Type	Overall shield. Shielded twisted pairs.
Approx. Dmax	8.5 mm.
Flexibility	High. Special for controlling servo drives, with a minimum bending radius under dynamic conditions (when flexed) of 12 times the Dmax. (= 102 mm).
Covering	PUR. Polyurethane immune to the chemical agents used in machine tools.
Temperature	Work: 0°C/+80°C (+32°F/+176°F). Storage: - 40°C/+80°C (- 40°F/+176°F).
Work voltage	U: 250 V.

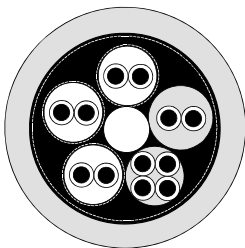

FM7/FM9

Ref.1107

CA-EEC-CT adapter cable diagram

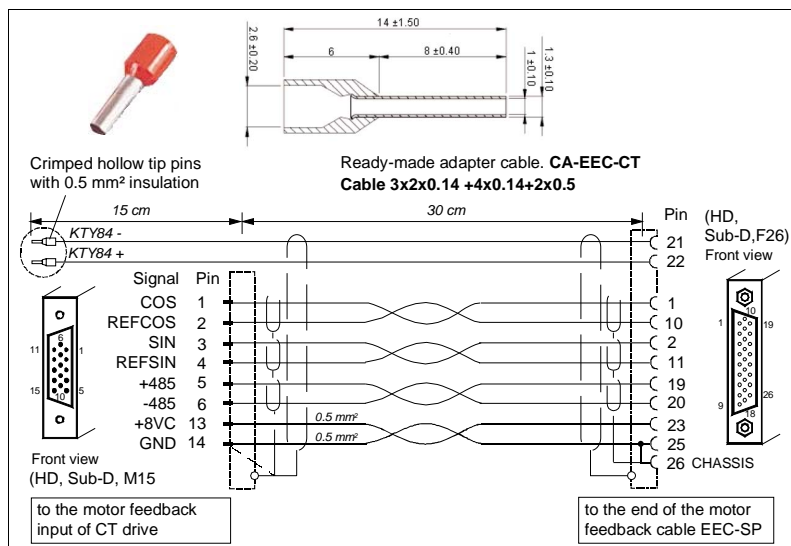

4.
INSTALLATION
Connections

F. 4/28

CA-EEC-CT adapter cable to be used with the EEC-SP cable to connect the SinCos™ encoder of the C axis of an FM9 motor and a CT series drive.

Sales reference and code

T. 4/20 Sales references and code of the CA-EEC-CT cable.

Reference	Service
CA-EEC-CT	Not available

Mechanical characteristics

T. 4/21 Mechanical characteristics of the CA-EEC-CT adapter cable.

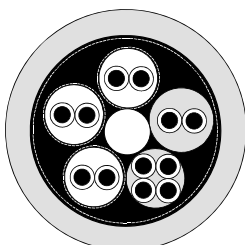

Type	Overall shield. Shielded twisted pairs.
Approx. Dmax	8.5 mm.
Flexibility	High. Special for controlling servo drives, with a minimum bending radius under dynamic conditions (when flexed) of 12 times the Dmax. (= 102 mm).
Covering	PUR. Polyurethane immune to the chemical agents used in machine tools.
Temperature	Work: 0°C/+80°C (+32°F/+176°F). Storage: - 40°C/+80°C (- 40°F/+176°F).
Work voltage	U: 250 V.

Connection of the motor feedback with CT series drives

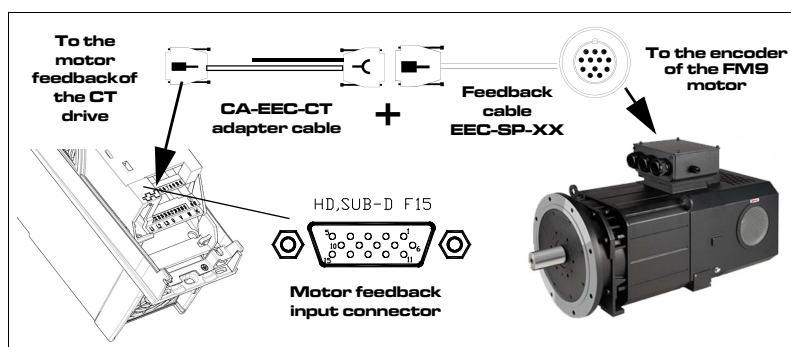

F. 4/29

Connection of the feedback of an FM9 spindle with a CT series drive.

The motor feedback of FM9 spindles to be governed by CT servo drives is a sinusoidal encoder. The connection must be made between the connector of the motor feedback and the 15-pin HD Sub-D, F15 female connector of the drive through the EEC-SP feedback cable together with a CA-EEC-CT adapter cable. See figure.



FM7/FM9

Ref.1107

4.2.3 Fan

4.
INSTALLATION
Connections

Fan connection on FM7 models

The fan integrated into the motors of the FM7 family is supplied with three-phase 400 V AC voltage at 50/60 Hz.

Note that the fan can also be connected to three-phase 460 V AC at 60 Hz.

It must be connected between the three mains phases and pins u/Z1, v/Z2 and w/Z3 located inside the terminal box. Observe that depending on whether it is an E01, E02 series motor or an E03, HS3 series motor, the location of the terminals to connect the fan inside the terminal box is different. See figure F. 4/30.

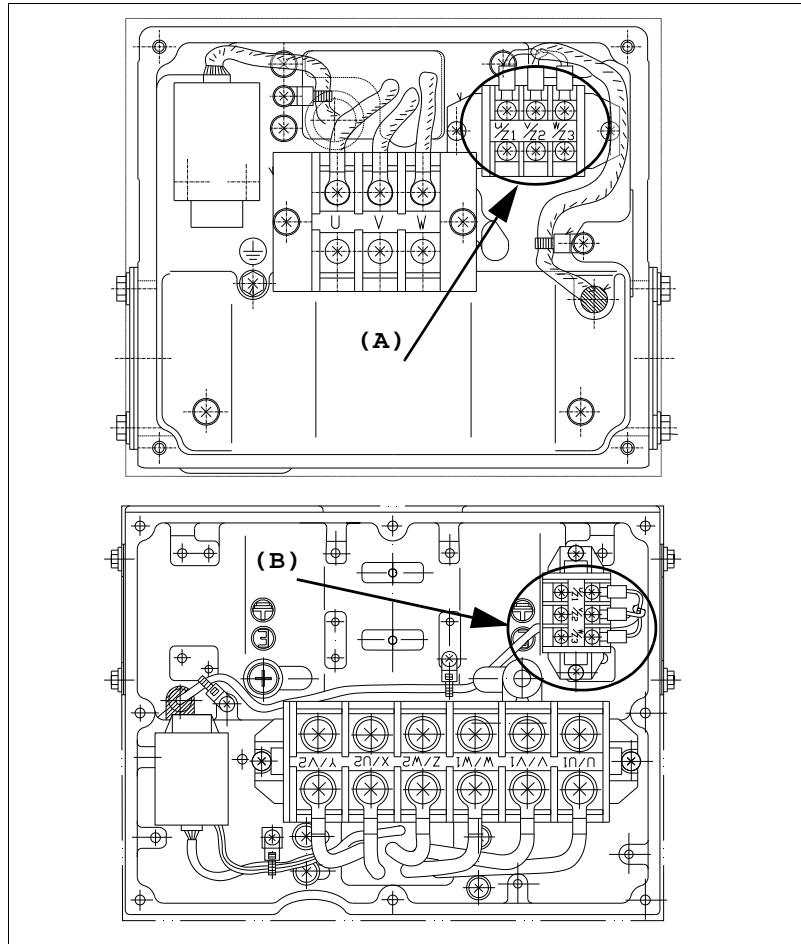

F. 4/30

Terminals in the terminal box for connecting the fan. **A.** Terminals u/Z1, v/Z2 and w/Z3 in E01 and E02 series. **B.** Terminals u/Z1, v/Z2 and w/Z3 in E03 and HS3 series.

NOTE . Layouts other than the one shown in figure F. 4/30 are also possible but the terminals may be easily located because they're identified in the same way u/Z1, v/Z2 and w/Z3.



FM7/FM9

Ref.1107

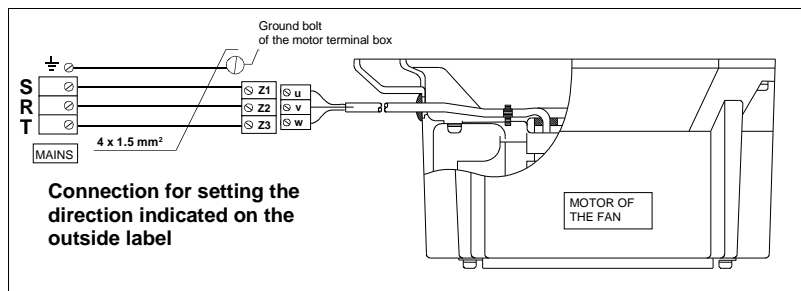

F. 4/31

Fan connection to mains.



WARNING . To set the direction of the air flow and the turning direction shown on the outside plate of the fan, the fan must be connected at the corresponding terminal strip inside the terminal box in this order: Terminal Z1 with mains phase S, terminal Z2 with phase R and terminal Z3 with phase T. The ground cable must be connected to the motor's ground bolt. Therefore, note that two of the phases are swapped.

When connecting Z1- phase R, Z2- phase S and Z3- phase T, the fan will turn in the opposite direction to the one shown on the label.

The fan will evacuate the heat towards the back of the motor (opposite direction to the machine) according to any of the two connections. However, one must always verify that the fan turns in the direction indicated on its outside label.

The following table offers the electrical data on voltage, frequency, power consumption and current absorbed by the fan.

T. 4/22 Electrical data of the integrated fan depending on motor model.

FM7-□□□□-□□□□-E01/E02				
Motor model	Voltage	Frequency	Power	Current
	V	Hz	W	Arms
FM7-A037-□□□□-E01/E02	400	50/60	37/51	0.11/0.14
	460	60	60	0.16
FM7-A055-□□□□-E01/E02	400	50/60	64/85	0.11/0.16
	460	60	96	0.17
FM7-A075-□□□□-E01/E02	400	50/60	41/62	0.07/0.10
	460	60	63	0.09
FM7-A090-□□□□-E01/E02	400	50/60	45/58	0.11/0.10
	460	60	63	0.10
FM7-A110-□□□□-E01/E02	400	50/60	59/83	0.11/0.14
	460	60	88	0.13
FM7-A150-□□□□-E01/E02	400	50/60	59/83	0.11/0.14
	460	60	88	0.13
FM7-A185-□□□□-E01/E02	400	50/60	58/82	0.11/0.14
	460	60	88	0.13
FM7-A220-□□□□-E01/E02	400	50/60	57/82	0.11/0.13
	460	60	87	0.13
FM7-B120-□□□□-E01/E02	400	50/60	58/82	0.11/0.14
	460	60	88	0.13
FM7-B170-□□□□-E01/E02	400	50/60	57/82	0.11/0.13
	460	60	87	0.13
FM7-A300-□□□□-E01	400	50/60	152/205	0.38/0.38
	460	60	226	0.40
FM7-B220-□□□□-E01	400	50/60	163/218	0.39/0.39
	460	60	238	0.41
FM7-A370-□□□□-E01	400	50/60	152/205	0.38/0.38
	460	60	226	0.40
FM7-B280-□□□□-E01	400	50/60	152/205	0.38/0.38
	460	60	226	0.40
FM7-A510-□□□□-E01/E02	400	50/60	86/117	0.22/0.23
	460	60	128	0.24
FM7-C215-□□□□-E01/E02	400	50/60	86/117	0.22/0.23
	460	60	128	0.24
FM7-C270-□□□□-E01/E02	400	50/60	103/140	0.18/0.23
	460	60	159	0.22
FM7-E600-C□B□-E01	400	50/60	94/132	0.22/0.25
	460	60	143	0.25

4.

INSTALLATION
Connections



FM7/FM9

Ref.1107

4.
INSTALLATION
Connections

T. 4/23 Electrical data of the integrated fan depending on motor model.

FM7-D□□□-S1D0-E03				
Motor model	Voltage	Frequency	Power	Current
	V	Hz	W	Arms
FM7-D055-S1D0-E03	400	50/60	64/85	0.11/0.16
	460	60	96	0.17
FM7-D075-S1D0-E03	400	50/60	41/62	0.07/0.10
	460	60	63	0.09
FM7-D110-S1D0-E03	400	50/60	59/83	0.11/0.14
	460	60	88	0.13
FM7-D150-S1D0-E03	400	50/60	59/83	0.11/0.14
	460	60	88	0.13
FM7-D185-S1D0-E03	400	50/60	58/82	0.11/0.14
	460	60	88	0.13
FM7-D220-S1D0-E03	400	50/60	57/82	0.11/0.13
	460	60	87	0.13

T. 4/24 Electrical data of the integrated fan depending on motor model.

FM7-D□□□-S1D0-HS3				
Motor model	Voltage	Frequency	Power	Current
	V	Hz	W	Arms
FM7-D075-S1D0-HS3	400	50/60	41/62	0.07/0.10
	460	60	63	0.09
FM7-D110-S1D0-HS3	400	50/60	59/83	0.11/0.14
	460	60	88	0.13
FM7-D185-S1D0-HS3	400	50/60	58/82	0.11/0.13
	460	60	88	0.13
FM7-D220-S1D0-HS3	400	50/60	57/82	0.11/0.13
	460	60	87	0.13



FM7/FM9

Ref.1107

Fan connection on FM9 models

The fan integrated into the motors of the FM9 family is supplied with three-phase 400 V AC voltage at 50 Hz.

Note that the fan can also be connected to three-phase 460 V AC at 60 Hz.

It must be connected between the three mains phases and pins U, V and W located inside the terminal box of the fan. See figure F. 4/32. Use a cable gland to insert the wires into the terminal box of the fan.

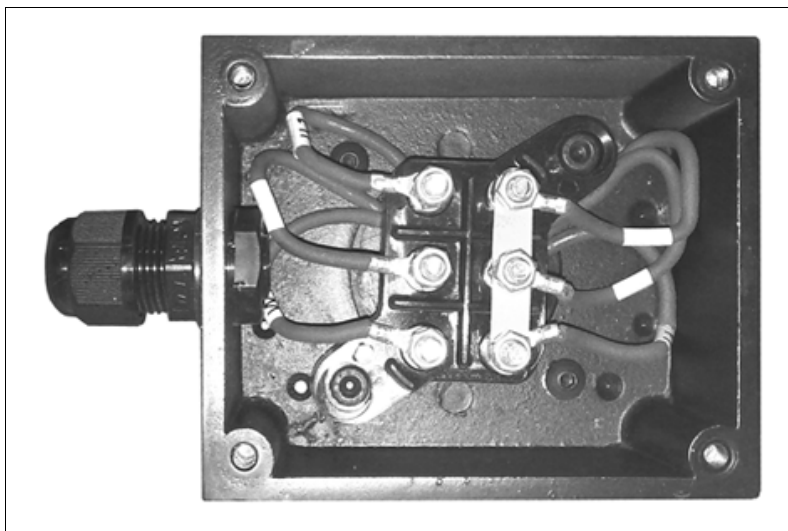

F. 4/32

Terminals in the terminal box of the fan for connecting it. A. Terminals U, V and W on FM9 motors, E01 series.

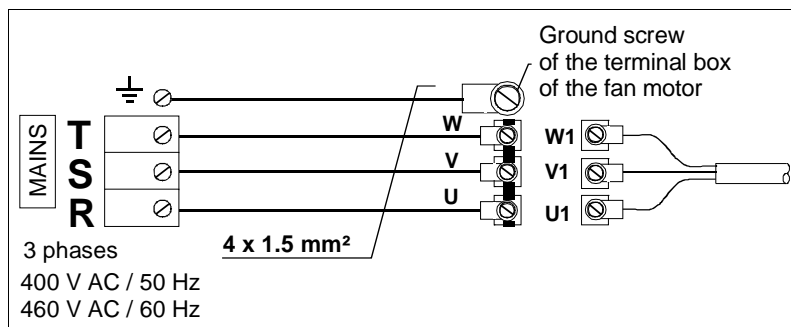

F. 4/33

Fan connection to mains.

The fan will evacuate the heat towards the back of the motor (opposite direction to the machine).

Electrical characteristics

The following table offers the electrical data on voltage, frequency, power consumption and current absorbed by the fan.

T. 4/25 Electrical data of the integrated fan depending on motor model.

FM9-□□□□-C5C□-E01				
Motor model	Voltage	Frequency	Power	Current
	V AC	Hz	W	Arms
FM9-B□□□-C5C□-E01	400	50	1500	3.25
	460	60	1750	3.20
FM9-A□□□-C5C□-E01	400	50	1500	3.25
	460	60	1750	3.20

4.

INSTALLATION
Connections



FM7/FM9

Ref.1107

4.

INSTALLATION

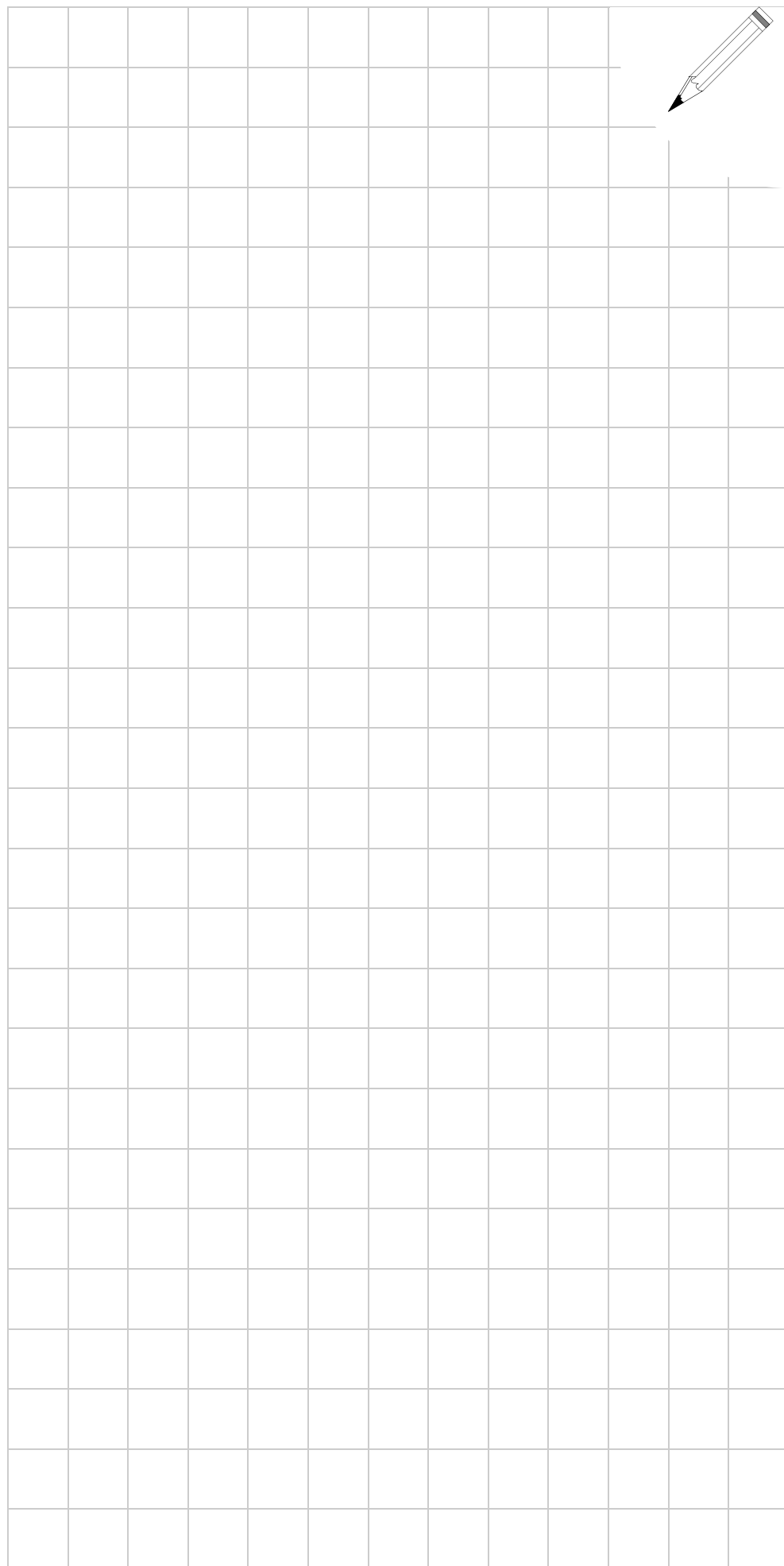
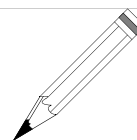

FM7/FM9

Ref.1107

5.1 Overview

5.1.1 Daily inspections

Check:

- For too much vibration or unusual noise.

T. 5/1 Normal noise level.

	Noise dB(A)		Noise dB(A)
FM7-A037-□□□□-E01/E02	≤ 75	FM7-D055-S1D0-E03	≤ 75
FM7-A055-□□□□-E01/E02	≤ 75	FM7-D075-S1D0-E03	≤ 75
FM7-A075-□□□□-E01/E02	≤ 75	FM7-D110-S1D0-E03	≤ 75
FM7-A090-□□□□-E01/E02	≤ 75	FM7-D150-S1D0-E03	≤ 75
FM7-A110-□□□□-E01/E02	≤ 75	FM7-D185-S1D0-E03	≤ 75
FM7-A150-□□□□-E01/E02	≤ 75	FM7-D220-S1D0-E03	≤ 75
FM7-A185-□□□□-E01/E02	≤ 75		
FM7-A220-□□□□-E01/E02	≤ 80	FM7-D075-S1D0-HS3	≤ 75
FM7-B120-□□□□-E01/E02	≤ 75	FM7-D110-S1D0-HS3	≤ 75
FM7-B170-□□□□-E01/E02	≤ 80	FM7-D185-S1D0-HS3	≤ 75
FM7-A300-□□□□-E01	≤ 80	FM7-D220-S1D0-HS3	≤ 75
FM7-B220-□□□□-E01	≤ 80		
FM7-A370-□□□□-E01	≤ 80	FM9-B055-C5C□-E01	-
FM7-B280-□□□□-E01	≤ 80	FM9-B071-C5C□-E01	-
FM7-A510-□□□□-E01/E02	≤ 80	FM9-A100-C5C□-E01	-
FM7-C215-□□□□-E01/E02	≤ 80	FM9-B113-C5C□-E01	-
FM7-C270-□□□□-E01/E02	≤ 80	FM9-A130-C5C□-E01	-
FM7-E600-C□B□-E01	≤ 80		

Remember that the data given in the table corresponds to sound pressure levels according to EN 21680 (tolerance +3 dB).

- For ambient temperature too high.

5.1.2 Periodic inspections



T. 5/2 Periodic inspections.

Area	Effect	Test	Corrective action
Bearings	Noise	Unusual noise or more noise	Replace the bearing
Bearings	Vibration	Unusual vibration	Replace the bearing
Bearings	Temperature	Unusual temperature increase	Replace the bearing
Bearings	Grease	Leaks	Eliminate the cause
Fan	Running status	Anomalous operation or not running	Eliminate the cause of the fan stop or replace the fan in case of a failure

5.1.3 Element replacement periods

If the running conditions were normal, i.e.

- Yearly average ambient temperature: 30°C (86°F).
- Load factor: 80% or lower
- Operating range: Maximum 12 hours a day.

T. 5/3 Element replacement periods on FM7 motors.

Area	Element	Test	Corrective action
Motor	Bearings	12000 hours or two years	Remove and replace the defective bearings or perform their required maintenance
Motor	Fan	15000 hours or two years	Replace the fan
Motor	Revisions	20000 hours or five years	Contact Fagor Automation S.Coop

5.2 Bearings

First inspection

The first inspection must be done after running for 500 hours for motors that have been running in normal conditions or before one year since they were installed.

Periodic inspections

The period for maintenance and inspections will depend on the type of bearing, dimensions, average speed and temperature conditions. In any case, It must be done within two years

Note. It will not be necessary to lubricate the bearings.



FM7/FM9

Ref.1107

5.3 Fan

5.3.1 Fan replacement

On FM7 motor models

The motor is cooled by an integrated fan located on top. If due to dust, dirt or for other reasons, it starts working poorly, it must be replaced immediately. See the relevant tables in the "spare parts" section of this chapter.



The fan must not be replaced nor the connection terminals of its electrical cables manipulated while the motor is connected to the power supply and/or the fan is connected to the three-phase line..



When replacing the fan, make sure that neither screws nor small items fall inside the motor.

It is recommended to proceed as follows when replacing the fan.

- Disconnect the motor from the power supply.
- Disconnect the fan from the three-phase line.
- Remove the fan cables from the terminal strip located in the terminal box. Take these cables out of the terminal box through the hole. To do that, remove the silicone in it and the fastener that secures it in order to make it easier to take it out. See the section "fan connection" of chapter 4 in this manual.
- Remove the 4 screws used to attach the fan housing to the motor block. See attached figure **F. 5/1**.

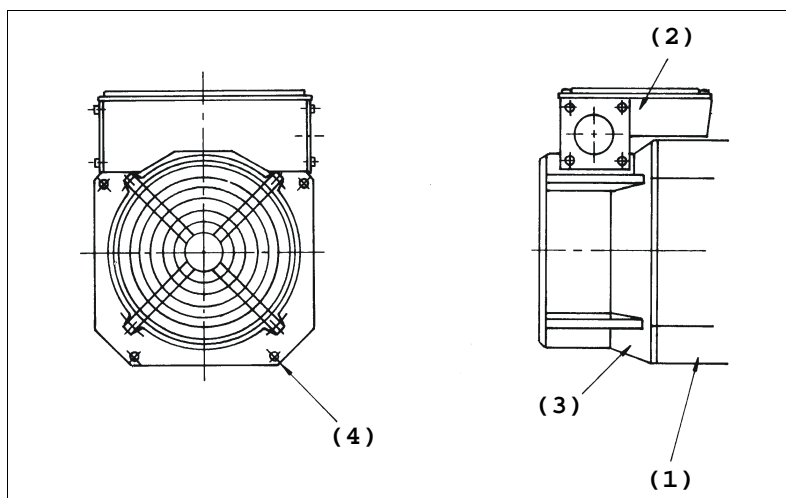

F. 5/1

Items attached to the fan housing.

1	Motor
2	Terminal box
3	Fan housing
4	Fan housing mounting screws (x4)

5.

MAINTENANCE
Fan



FM7/FM9

Ref.1107

5.
MAINTENANCE
 Fan

- Remove the screw used to attach the terminal box to the fan housing. See attached figure **F. 5/2**.

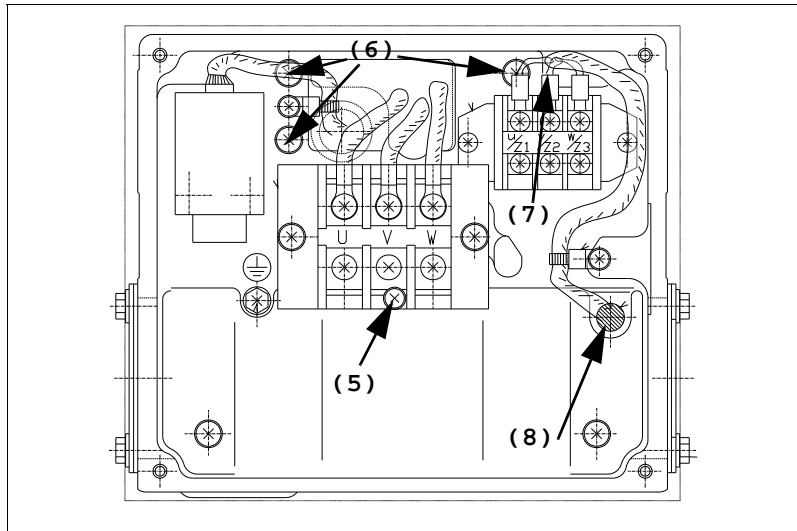

F. 5/2

Links between the fan housing, the terminal box and the motor block on FM7 (E01 and E02 series) motors.

5	Screw to attach the terminal box to the fan housing
6	Screws to attach the terminal box to the motor block
7	Cables with terminals of the three-phase fan
8	Hole to feed the hose of the fan cables.

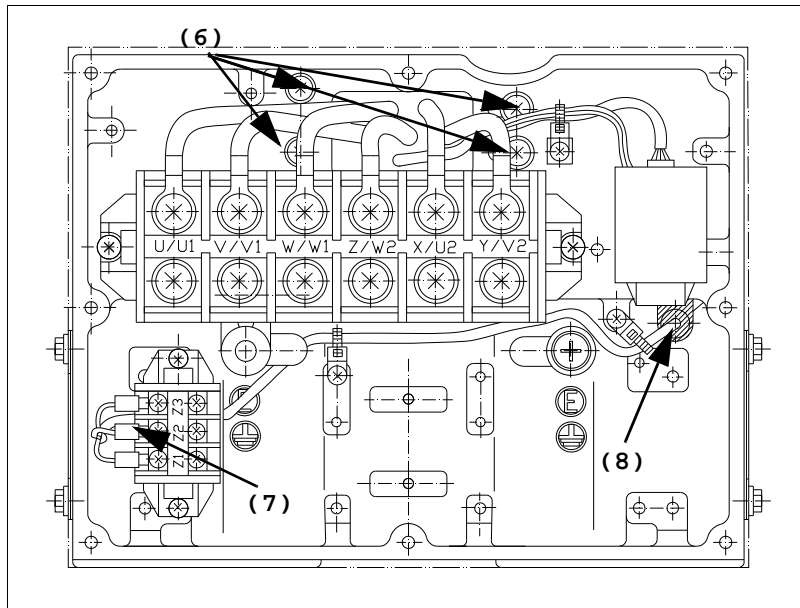

F. 5/3

Links between the fan housing, the terminal box and the motor block on FM7 (E03 and HS3 series) motors.

- Take the fan assembly (housing + motor) out as a single (whole) unit.



If when taking the fan assembly out gets in the way of the terminal box making it hard to take it out, loosen the screws that attach the terminal box to the motor block.



FM7/FM9

Ref.1107

- Follow these steps backwards to install the replacement fan.



Once the new fan has been installed, do not forget to cover the hole for feeding the cable from the fan to the terminal box and fasten the cable again like it was originally. The E03 or HS3 series models have this cable fastened in two points of the terminal box they both must be tightened with a screw. See figure **F. 5/3**.

Remember that all these accessories are also supplied by Fagor. They come in a bag inside the terminal box of the motor. It has fasteners, screws and a rubber seal to cover the hole that is now empty after removing the silicone to free the fan connection cable when it has been replaced.

On FM9 motor models

Contact Fagor Automation S. Coop.

5.MAINTENANCE
Fan**FAGOR** **FM7/FM9****Ref.1107**

5.4 Spare parts

The following tables show the models for the spare parts of the motor.

5.4.1 FM7. E01 and E02 series

T. 5/4 Spare parts for motors whose base speed is 1500 rpm.

	FM7- A ●●● - □□□□ - E01/E02			
●●●	037	055	075	090
Encoder	TTL (UTMSI -10AAGAZA), C axis (SinCos [®] SRS50)			
Fan	B935P5653-1		B032P0426-1	

T. 5/5 Spare parts for motors whose base speed is 1500 rpm.

	FM7- A ●●● - □□□□ - E01/E02			
●●●	110	150	185	220
Encoder	TTL (UTMS -10AAGAZE), C axis (SinCos [®] SRS50)			
Fan	B032P0427-1			

T. 5/6 Spare parts for motors whose base speed is 1500 rpm.

	FM7- A ●●● - □□□□ - E01/E02		
●●●	300	370	510
Encoder	TTL (UTMSI -10AAGBZA), C axis (SinCos [®] SRS50)		
Fan	B935P5659-1		B935P6496-1

T. 5/7 Spare parts for motors whose base speed is 1250 rpm.

	FM7- E ●●●-C□B□ - E01	
●●●	600	
Encoder	C axis (SinCos [®] SRS50)	
Fan	B935P6496-1	

T. 5/8 Spare parts for motors whose base speed is 1000 rpm.

	FM7- B ●●● - □□□□ - E01/E02			
●●●	120	170	220	280
Encoder	TTL (UTMSI -10AAGAZE) C axis (SinCos [®] SRS50)		TTL (UTMSI -10AAGBZA) C axis (SinCos [®] SRS50)	
Fan	B032P0427-1		B935P5659-1	

T. 5/9 Spare parts for motors whose base speed is 500 rpm.

	FM7- C ●●● - □□□□ - E01/E02	
●●●	215	270
Encoder	TTL (UTMSI -10AAGBZA), C axis (SinCos [®] SRS50)	
Fan	B935P6496-1	



FM7/FM9

Ref.1107

5.4.2 FM7. E03 series

T. 5/10 Spare parts for motors whose base speed is 1500/4000 rpm. (Y/Delta, star/triangle). Winding-selectable motor

	FM7- D ●●● - S1D0 - E03	
●●●	055	075
Encoder	TTL (UTMSI -10AAGAZA)	
Fan	B032P0426-1	

T. 5/11 Spare parts for motors whose base speed is 1500/4000 rpm. (Y/Delta, star/triangle). Winding-selectable motor

	FM7- D ●●● - S1D0 - E03			
●●●	110	150	185	220
Encoder	TTL (UTMSI -10AAGAZA)			
Fan	B032P0427-1			

5.4.3 FM7. HS3 series

T. 5/12 Spare parts for motors whose base speed is 1500/4000 rpm. (Y/Delta, star/triangle). Winding-selectable motor

	FM7- D ●●● - S1D0 - HS3			
●●●	075	110	185	220
Encoder	TTL (UTMSI -10AAGAZB)			
Fan	B032P0426-2	B032P0427-2		

5.4.4 FM9. E01series

T. 5/13 Spare parts for motors whose base speed is 1500 rpm (star -Y-).

	FM9 - A ●●● - C5Cx - E01			
●●●	100	130		
Encoder	SinCos® Stegmann® SRS64			
Fan	Contact Fagor			

T. 5/14 Spare parts for motors whose base speed is 1000 rpm (star -Y-).

	FM9 - B ●●● - C5Cx - E01			
●●●	055	071	113	
Encoder	SinCos® Stegmann® SRS64			
Fan	Contact Fagor			

5.

MAINTENANCE
Spare parts



FM7/FM9

Ref.1107

Any motor selection process must consider five basic aspects that condition the performance characteristics of the motor-machine assembly:

- ❑ The characteristics of the motor.
- ❑ The load requirements.
- ❑ The service conditions.
- ❑ The ambient conditions.
- ❑ The supply voltage.

6.1 Spindle motor selection

On the spindles of machine tools, it is important to maintain a constant turning speed of the spindle. To control this speed, the drive applies torque to the load according to the characteristics of this load as well as to the adjusted accelerations and decelerations.

Procedure to calculate the needed motor power:

- ❑ Determine the required rated power values (in continuous duty cycle, instantaneous and periodically) depending on the characteristics of the load.
- ❑ Increase the value of that required power considering the power transmission efficiency and load dispersion.
- ❑ Select the drive that supplies the necessary current to govern the motor in all the duty cycles that the machine will work in).

6.1.1 Power demanded from a motor for a particular load

To determine the needed motor power, use the following formula:

$$P_{\text{MOTOR}} > P_{\text{LOAD}} + P_{\text{ACCEL/DECEL}}$$

The power of the motor must be greater than the sum of the power required by the load and the power required by the machine's accelerations and decelerations.

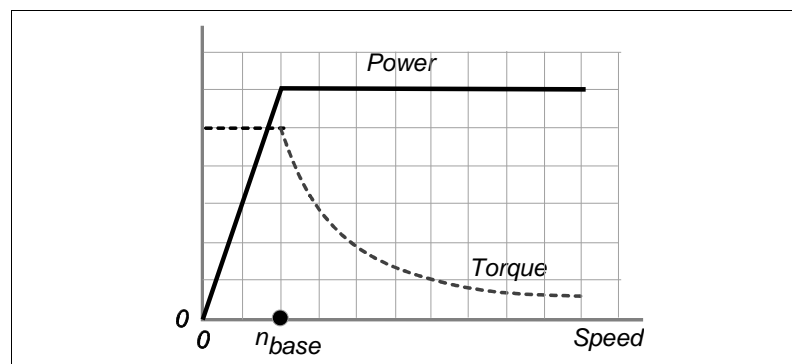

F. 6/1

Constant power required from the motor for a load regardless of the load.

6.

SELECTION
Spindle motor selection

T. 6/1 Constant motor power demanded by a load.

Constant motor power	
Load type	Constant power, regardless of speed
Examples	Winding machines at constant tension Milling spindle Lathe spindle
Torque / speed characteristics	The torque decreases from base speed on
Motor Power	The rated power of the drive will be the one demanded by the load.

6.1.2 Power required by the load

The power demanded from a spindle motor in a turning or machining center is determined by the cutting power.

A good cutting process required the spindle motor to be working at constant power and with a power range between 1:3 and 1:5.

The powers used in cutting on a lathe, on a milling machine or on machining center with drilling are calculated using these formulae.

For a more accurate calculation of the power required, one must bear in mind different factors such as cutting oil, material, shape of the tools, hardness of the material machined, etc.

For lathe work, a cutting blade forces against the part to be machined, while this is turning. See figure F. 6/2.

The power required in this case **P_c** is calculated as follows:

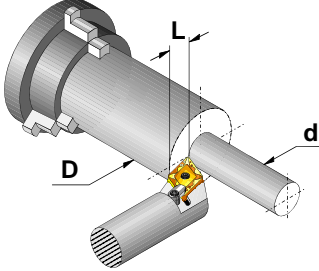

$$P_c = \frac{K_s d L V}{60 \cdot 1000 \cdot \eta_c} = \frac{d L V}{S_c \eta_c} \text{ (kW)}$$

$$V = \frac{\pi \cdot D N_s}{1000} \text{ (m/(min))}$$

F. 6/2

Machining for lathe. Cutting power.

where:

Symb.	Description	Units
K_s	Relative cutting resistance	N·mm ²
d	Cutting depth	mm
L	Cutter length or feed per full rotation	mm
D	Diameter of the machine part	mm
N_s	Spindle turning speed	rpm
η_c	Mechanical efficiency (varies from 0.7 to 0.85)	non-dimensional
S_c	Cutting efficiency. Cutting volume per kilowatt every minute	(cm ³ /kW)/min

In the case of a milling machine, the cutter is mounted on the spindle itself and turns with this to cut the material. See figure F. 6/3.



FM7/FM9

Ref.1107

The power required in this case **Pf** is calculated as follows:

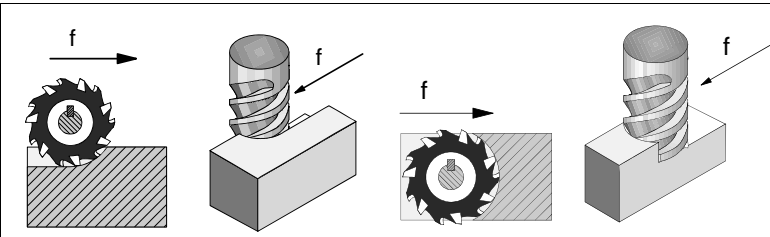

$$P_f = \frac{K_s d W f}{60 \cdot 1000^2 \cdot \eta_f} = \frac{d W f}{1000^2 \cdot S_f \eta_f} \quad (\text{kW})$$

F. 6/3

Machining for mill. Cutting power.

where:

Symb.	Description	Units
Ks	Relative cutting resistance	N·mm ²
d	Cutting depth	mm
W	Cutting width	mm
f	Feedrate	mm/min
Ns	Spindle turning speed	rpm
ηf	Mechanical efficiency (varies from 0.7 to 0.8)	non-dimensional
Sf	Cutting efficiency. Cutting volume per kilowatt every minute	(cm ³ /kW)/min

In the case of a drill, the bit is mounted on the spindle itself and turns with this to drill the material. See figure **F. 6/4**.

Te power required in this case **Pd** is calculated as below:

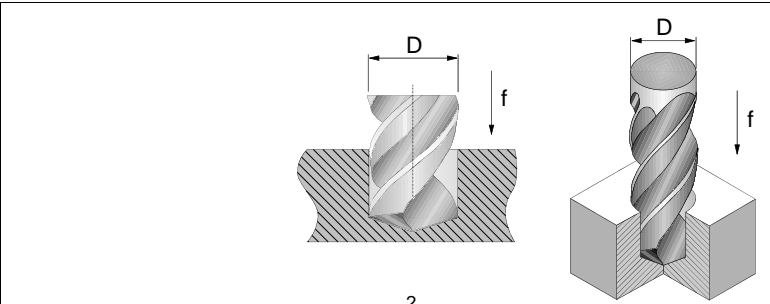

$$P_d = \frac{M \cdot 2\pi n}{60 \cdot 100 \cdot 1000 \cdot \eta_d} = \frac{\pi D^2 f}{4 \cdot 1000 \cdot S_d \eta_d} \quad (\text{kW})$$

F. 6/4

Drilling. Required power.

where:

Symb.	Description	Units
M	Drilling load torque	N·cm
n	Spindle turning speed	rpm
D	Hole diameter	mm
f	Feedrate	mm/min
ηd	Mechanical efficiency (varies from 0.7 to 0.85)	non-dimensional
Sd	Cutting efficiency. Cutting volume per kilowatt every minute	(cm ³ /kW)/min

In the event of governing a **gravitational load**, the power required depends very much on the presence on absence of balance weights. (crane or elevator). See figure **F. 6/5**.

6.

SELECTION
Spindle motor selection



FM7/FM9

Ref.1107

6.

SELECTION
Spindle motor selection

The power required in this case, P_{GL} and P_{GLC} is calculated in the following way:

$$P_{GL} = \frac{m_L \cdot V}{6120 \cdot \eta} \quad (\text{kW})$$

$$P_{GLC} = \frac{(m_L - m_C) \cdot V}{6120 \cdot \eta} \quad (\text{kW})$$

F. 6/5

Gravitational load. Required power.

where:

Symb.	Description	Units
V	Linear speed	m/min
m_L	Load mass	kg
η	Mechanical efficiency	non-dimensional
m_C	Cutting efficiency	(cm ³ /kW)/min

Governing a **frictional load**, this is the case of horizontal movements such as a conveyor belt or a movable table, the required power depends on the friction coefficient μ . See figure **F. 6/6**.

The power required in this case P_F , is calculated as follows.

$$P_F = \frac{\mu \cdot m_L \cdot V}{6120 \cdot \eta} \quad (\text{kW})$$

F. 6/6

Frictional load. Required power.

where:

Symb.	Description	Units
μ	Friction coefficient	non-dimensional
m_L	Load mass	kg
η	Mechanical efficiency	non-dimensional
V	Linear speed	m/min



FM7/FM9

Ref.1107

6.1.3 Power needed to accelerate or decelerate the spindle motor.

There are three methods to control the acceleration and deceleration process of the machine spindle:

- Acceleration limited by time.

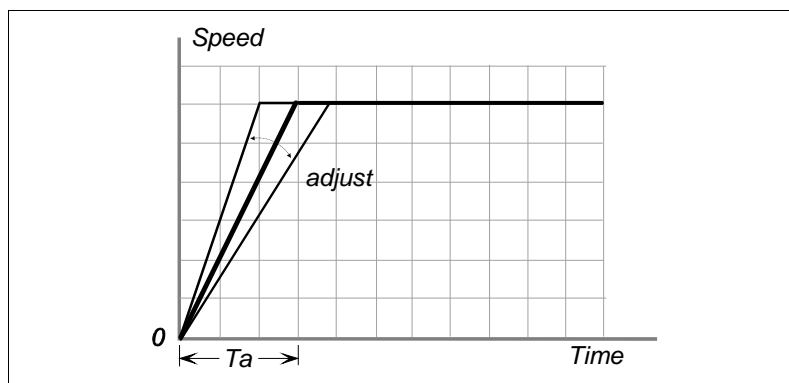

F. 6/7

Acceleration limited by time.

T. 6/2 Acceleration limited by time.

Method	Acceleration limited by time.
Control	Speed increases linearly in time until the command speed is reached.
Comment	The acceleration torque is constant.

- Different acceleration ramps depending on the speed reached.

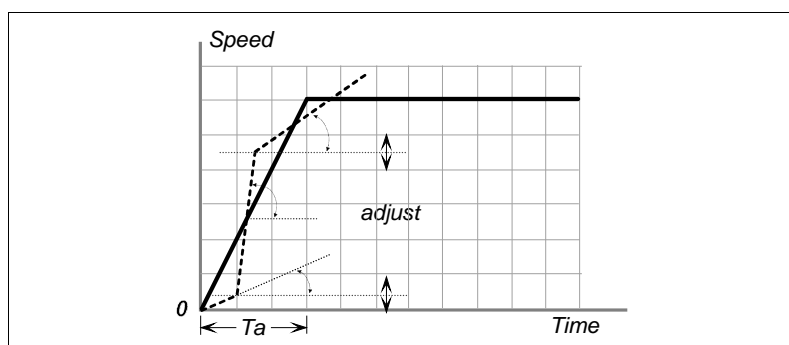

F. 6/8

Different accelerations depending on reached speed.

T. 6/3 Different accelerations depending on reached speed.

Method	Different accelerations depending on speed.
Control	Linear acceleration avoiding abrupt variations in transmitted torque.
Comment	Emulation of the square sine function for speed by using ramps.

- Limited acceleration and choke. Choke = $(\Delta \text{ acceleration} / \Delta t)$.

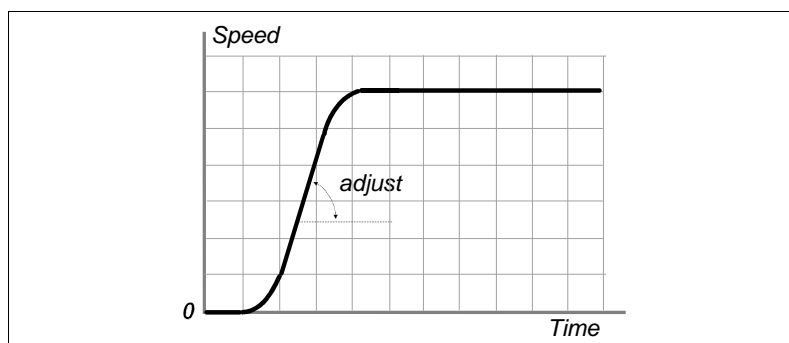

F. 6/9

Acceleration and choke limit.

6.

SELECTION
Spindle motor selection

T. 6/4 Acceleration and choke limit.

Method	Acceleration and choke limit.
Control	Progressive linear acceleration, avoiding abrupt variations of transmitted torque.
Comment	Approach square sine function (bell shape) for the speed.

The capability demanded from the motor is determined by the following formulas:

Capacity required by the motor in the constant torque area:
($0 < N_M < N_B$)

$$P_N = \left(\frac{2\pi}{60} \right)^2 \cdot \frac{J_M \cdot N_M^2}{1000 \cdot t} \quad (\text{kW})$$

Capacity required by the motor in the constant torque and constant power area:
($0 < N_M < N_{max}$)

$$P_N = \left(\frac{2\pi}{60} \right)^2 \cdot \frac{J_M \cdot (N_M^2 + N_B^2)}{2000 \cdot t} \quad (\text{kW})$$

where:

Symb.	Description	Units
J_M	Load inertia viewed from the motor shaft	kg·m ²
P_N	Rated power at base speed	kW
N_{max}	Maximum motor speed	rpm
N_B	Motor base speed	rpm
N_M	Motor speed reached after a time period t	rpm
t	Duration of the acceleration until reaching N_M .	s

We will now give several examples of calculations using a mechanical specifications and for a standard motor. The results could vary from real ones through mechanical losses, fluctuations in mains voltage, or inaccuracies of mechanical data.

Example.

Data:

Acceleration time:

[1] Between 0 and 1500 rpm in 0.5 s

[2] Between 0 and 6000 rpm in 2.5 s

Motor inertia:

$$J_{\text{motor}} = 0.13 \text{ kg}\cdot\text{m}^2$$

Motor base speed:

$$N_B = 1500 \text{ rpm}$$

Calculations:

[1] With speed between 0 and 1500 rpm.

$$P_N = \left[\frac{2\pi}{60} \right]^2 \cdot \frac{J_M \cdot N_M^2}{1000 \cdot t} \text{ [kW]} = \left[\frac{2\pi}{60} \right]^2 \cdot \frac{0.13 \cdot 1500^2}{1000 \cdot 0.5} = 6.41 \text{ [kW]} \quad [1]$$

[2] With speed between 0 and 6000 rpm.

$$P_N = \left[\frac{2\pi}{60} \right]^2 \cdot \frac{J_M [N_M^2 + N_B^2]}{2000 \cdot t} \text{ [kW]} = \left[\frac{2\pi}{60} \right]^2 \cdot \frac{0.13 [6000^2 + 1500^2]}{2000 \cdot 2.5} = 10.89 \text{ [kW]} \quad [2]$$



FM7/FM9

Ref.1107

Calculation of acceleration and braking time

After selecting the mechanical characteristics and the power of the drive, the acceleration and braking time is calculated as follows:

Constant torque area:
($0 < N_M < N_B$)

$$t_1 = \frac{2\pi \cdot J_M \cdot N_M}{60 \cdot T_M} \text{ (s)}$$

Constant power area:
($N_B < N_M < N_{max}$)

$$t_2 = \frac{2\pi \cdot J_M \cdot (N_M^2 - N_B^2)}{120 \cdot T_M \cdot N_B} \text{ (s)}$$

Constant torque & power area:
($N_B < N_M < N_{max}$)

$$t_3 = (t_1 + t_2) = \frac{2\pi \cdot J_M \cdot (N_M^2 + N_B^2)}{120 \cdot T_M \cdot N_B} \text{ (s)}$$

where:

Symb.	Description	Units
J_M	Load inertia viewed from the motor shaft.	kg·m ²
T_M	Rated torque at base speed.	N·m
N_{max}	Maximum motor speed.	rpm
N_B	Motor base speed.	rpm
N_M	Motor speed reached after a time period t.	rpm

Calculation of power with intermittent load

Forming the drive to the right dimensions has to be done with the greatest care when the application involves a periodical starting and stopping operation, frequently repeated as in the case of threading with a miller.

For a cycle like the one shown in the **F. 6/10** which includes acceleration and stopping, the equivalent effective torque T_R of equation must be within the S1 dimension given for the drive torque.

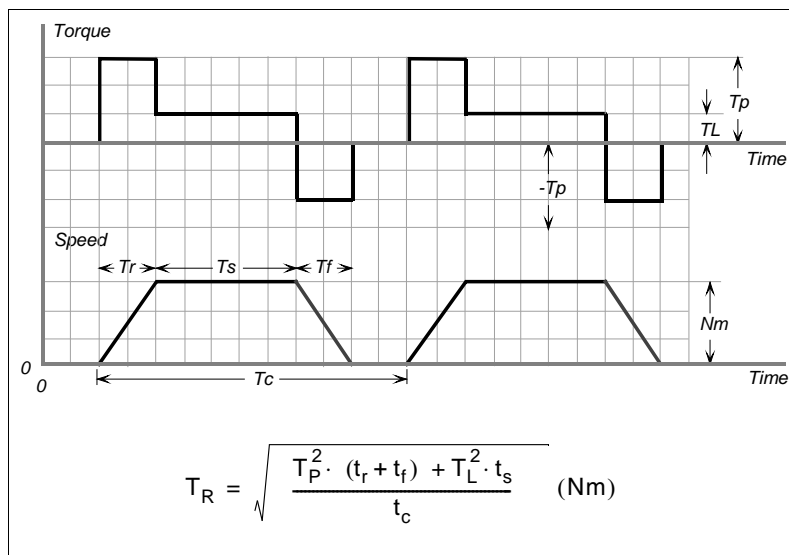

F. 6/10

Periodic start-stop operation

6.

SELECTION
Spindle motor selection



FM7/FM9

Ref.1107

6.2 Technical characteristics

6.2.1 FM7-XXXX-XXXX-E01/E02 series

T. 6/5 Technical data. Assigning the drive to the corresponding motor model.

	Rated torque	Rated power		Spindle drive	
	Mn (S1)	Pn (S1)	Pn (S6-40%)	References	
	N·m	kW	kW	Modular	Compact
FM7-A037-□□□□-E01/E02	23.5	3.7	5.5	SPD 1.25	SCD 1.25A
FM7-A055-□□□□-E01/E02	35.0	5.5	7.7	SPD 1.25	SCD 1.25A
FM7-A075-□□□□-E01/E02	47.7	7.5	11.0	SPD 1.35	SCD 2.35
FM7-A090-□□□□-E01/E02	57.4	9.0	13.0	SPD 2.50	SCD 2.50
FM7-A110-□□□□-E01/E02	70.0	11.0	15.5	SPD 2.50	SCD 2.50
FM7-A150-□□□□-E01/E02	95.5	15.0	22.0	SPD 2.75	-
FM7-A185-□□□□-E01/E02	117.8	18.5	26.0	SPD 2.85	-
FM7-A220-□□□□-E01/E02	140.0	22.0	33.0	SPD 3.100	-
FM7-B120-□□□□-E01/E02	114.6	12.0	18.5	SPD 2.75	-
FM7-B170-□□□□-E01/E02	162.3	17.0	25.0	SPD 2.85	-
FM7-A300-□□□□-E01	191.0	30.0	45.0	SPD 3.150	-
FM7-B220-□□□□-E01	210.0	22.0	33.0	SPD 3.100	-
FM7-A370-□□□□-E01	235.0	37.0	56.0	SPD 3.200	-
FM7-B280-□□□□-E01	267.4	28.0	42.0	SPD 3.150	-
FM7-A510-□□□□-E01/E02	325.0	51.0	71.0	SPD 3.200	-
FM7-C215-□□□□-E01/E02	410.6	21.5	29.0	SPD 3.150	-
FM7-C270-□□□□-E01/E02	515.7	27.0	37.0	SPD 3.200	-
FM7-E600-C□B□-E01	458.4	60.0	80.0	SPD 3.200	-

T. 6/6 Technical data.

	Vbase	Rated current	Inertia	Max. speed		Current without	Rated voltage	Mass
	n _N	In (S1)	J	nmax		I _o	Un	P
				E01	E02			
	rpm	Arms	kg·cm ²	rpm		Arms	V	kg
FM7-A037-□□□□-E01/E02	1500	12.4	140	9000	1200	8.45	288.6	47/49
FM7-A055-□□□□-E01/E02	1500	14.6	210	9000	1000	7.34	304.1	52/56
FM7-A075-□□□□-E01/E02	1500	19.8	260	9000	1000	9.47	301.7	59/64
FM7-A090-□□□□-E01/E02	1500	25.0	330	9000	1000	12.04	282.1	68/73
FM7-A110-□□□□-E01/E02	1500	28.0	690	9000	1000	13.54	302.9	94/110
FM7-A150-□□□□-E01/E02	1500	39.4	690	8000	9000	19.51	297.6	94/110
FM7-A185-□□□□-E01/E02	1000	35.0	890	8000	9000	20.96	286.6	120/130
FM7-A220-□□□□-E01/E02	1500	47.5	890	8000	9000	24.98	305.0	120/130
FM7-B120-□□□□-E01/E02	1500	61.4	1080	8000	9000	36.07	291.1	135/145
FM7-B170-□□□□-E01/E02	1000	47.3	1080	8000	9000	24.92	284.7	135/145
FM7-A300-□□□□-E01	1500	82.1	2310	6500	-----	43.20	279.7	220/230
FM7-B220-□□□□-E01	1000	64.9	2310	6500	-----	35.46	267.3	220/230
FM7-A370-□□□□-E01	1500	90.0	2660	6500	-----	35.26	293.1	250/260
FM7-B280-□□□□-E01	1000	78.2	2660	6500	-----	38.16	269.0	250/260
FM7-A510-□□□□-E01/E02	1500	115.2	4730	5000	6000	43.83	314.3	340/350
FM7-C215-□□□□-E01/E02	500	87.9	4730	5000	6000	36.73	190.3	340/350
FM7-C270-□□□□-E01/E02	500	117.0	5840	5000	6000	48.18	177.5	380/390
FM7-E600-C□B□-E01	1250	117.4	8720	5000	-----	53.49	370.4	525/540

6.

SELECTION
Technical characteristics



FM7/FM9

Ref.1107

6.2.2 FM9-XXXX-C5CX-E01 series

T. 6/7 Technical data. Assigning the drive to the corresponding motor model.

	Rated torque		Rated power		Spindle drive
	Mn (S1/S6-40%)		Pn (S1/S6-40%)		
	N-m		kW		References
FM9-B055-C5C□-E01	525.2/687.5		55/72		SPD 3.200
FM9-B071-C5C□-E01	678.0/1002.6		71/105		SPD 3.250
FM9-A100-C5C□-E01	636.6/865.8		100/136		*
FM9-B113-C5C□-E01	1079.0/1461.0		113/153		*
FM9-A130-C5C□-E01	827.6/1133.1		130/178		*

* See the drive associated with the motor in the **REG. CT SERIES** manual.

T. 6/8 Technical data.

	Vbase	Rated current	Inertia	Vmax	Current without	Voltage without	Mass
	n _N	In (S1)	J	nmax	Io	Vo	P
	rpm	Arms	kg·cm ²	rpm	Arms	V	B+P
FM9-B055-C5C□-E01	1000	104.4	6900	5000	39.4	350	440
FM9-B071-C5C□-E01	1000	134.8	14790	4500	38.6	350	680
FM9-A100-C5C□-E01	1500	189.9	14790	4500	75.2	350	635
FM9-B113-C5C□-E01	1000	214.6	23260	4500	81.1	350	860
FM9-A130-C5C□-E01	1500	246.9	19300	4500	106.0	350	745

6.2.3 FM7-DXXX-S1D0-E03 series

T. 6/9 Technical data. Assigning the drive to the corresponding motor model.

	Rated torque		Rated power				Drive
	Mn (S1)		Pn (S1)		Pn (S6-40%)		Modular
	▲	Δ	▲	Δ	▲	Δ	
	N-m		kW		kW		
FM7-D055-S1D0-E03	35.0	13.1	5.5	5.5	7.7	10.0	SPD 1.35
FM7-D075-S1D0-E03	47.7	17.9	7.5	7.5	11.0	13.0	SPD 2.50
FM7-D110-S1D0-E03	70.0	26.3	11.0	11.0	15.5	20.0	SPD 2.75
FM7-D150-S1D0-E03	95.5	35.8	15.0	15.0	22.0	26.0	SPD 2.85
FM7-D185-S1D0-E03	117.8	44.2	18.5	18.5	26.0	32.0	SPD 2.85
FM7-D220-S1D0-E03	140.1	52.5	22.0	22.0	33.0	40.0	SPD 3.100

T. 6/10 Technical data.

	Vbase		Rated current				Inertia	Vmax	Mass
	n _N		In (S1)		In (S6-40%)		J	nmax	P
	▲	Δ	▲	Δ	▲	Δ			
	rpm	rpm	Arms	Arms	Arms	Arms	kg·cm ²	rpm	kg
FM7-D055-S1D0-E03	1500	4000	20.3	20.7	26.2	27.6	210	15000	67
FM7-D075-S1D0-E03	1500	4000	26.5	25.8	35.7	34.5	260	15000	74
FM7-D110-S1D0-E03	1500	4000	38.0	40.0	50.0	51.9	690	12000	110
FM7-D150-S1D0-E03	1500	4000	46.4	45.7	63.3	62.3	690	12000	110
FM7-D185-S1D0-E03	1500	4000	49.2	49.2	63.0	70.5	890	12000	135
FM7-D220-S1D0-E03	1500	4000	62.3	61.7	82.5	86.4	1080	12000	150



SELECTION
Technical characteristics



FM7/FM9

Ref.1107

6.2.4 FM7-DXXX-S1D0-HS3 series

T. 6/11 Technical data. Assigning the drive to the corresponding motor model.

	Rated torque		Rated power				Drive
	Mn (S1)		Pn (S1)		Pn (S6-40%)		Modular
	▲	Δ	▲	Δ	▲	Δ	
	N·m		kW		kW		
FM7-D075-S1D0-HS3	47.7	17.9	7.5	7.5	11.0	13.0	SPD 2.50
FM7-D110-S1D0-HS3	70.0	26.3	11.0	11.0	15.5	20.0	SPD 2.75
FM7-D185-S1D0-HS3	117.8	44.2	18.5	18.5	26.0	32.0	SPD 2.85
FM7-D220-S1D0-HS3	140.1	52.5	22.0	22.0	33.0	40.0	SPD 3.100

T. 6/12 Technical data.

	Vbase		Rated current				Inertia	Max. speed	Mass
	n _N		In (S1)		In (S6-40%)		J	n _{max}	P
	▲	Δ	▲	Δ	▲	Δ			B
	rpm	rpm	Arms	Arms	Arms	Arms	kg·cm ²	rpm	kg
FM7-D075-S1D0-HS3	1500	4000	26.5	25.8	35.7	34.5	260	15000	77
FM7-D110-S1D0-HS3	1500	4000	38.0	40.0	50.0	51.9	690	12000	115
FM7-D185-S1D0-HS3	1500	4000	49.2	49.2	63.0	70.5	890	12000	140
FM7-D220-S1D0-HS3	1500	4000	62.3	61.7	82.5	86.4	1080	12000	155

▲ Y (star) connection of the stator winding.
 Δ Delta (triangle) connection of the stator winding.

6.

SELECTION
Technical characteristics



FM7/FM9

Ref.1107

6.3 Spindle drive selection

Once the necessary motor model has been selected following the selection criteria, one must determine the reference of the modular spindle drive SPD associated with the motor. Check the technical characteristics table of the motor, given in the previous section that shows the drive associated with the motor in its last columns for modular SPD drives and for compact SCD drives.

The data to be checked when selecting a modular SPD drive for FM7 motor series (E01, E02, E03 and HS3) or FM9 motor series (E01) are:

- The value $0.7 \times I_n (S1)$ of the drive must be higher than or equal to the magnetizing current (or without load) of the motor.
- The current $I_n (S1)$ of the drive must be higher than or equal to the rated current of the motor.
- The current $I (S6-40\%)$ of the drive must be higher than or equal to the current $I (S6-40\%)$ of the motor.

Note. This condition may not be required depending on the application.

- The I_{max} current supplied by the drive must be enough for the spindle to accelerate to its maximum work speed in the required amount of time.



T. 6/13 Technical data. FM7. E01 and E02 series.

Motor	Current (Arms)			Drive Ref.	Current (Arms)		
	I_o	$I_n (S1)$	IS6-40%		$0.7 \times I_n$	$I_n (S1)$	IS6-40%
FM7-A037-□□□□-E01/E02	8.45	12.4	15.8	SPD 1.25	11.2	16.0	20.8
FM7-A055-□□□□-E01/E02	7.34	14.6	18.9	SPD 1.25	11.2	16.0	20.8
FM7-A075-□□□□-E01/E02	9.47	19.8	27.0	SPD 1.35	16.2	23.1	30.0
FM7-A090-□□□□-E01/E02	12.04	25.1	33.6	SPD 2.50	21.7	31.0	40.3
FM7-A110-□□□□-E01/E02	13.54	27.9	36.5	SPD 2.50	21.7	31.0	40.3
FM7-A150-□□□□-E01/E02	19.51	39.3	52.8	SPD 2.75	29.0	42.0	54.6
FM7-A185-□□□□-E01/E02	24.98	47.4	61.5	SPD 2.85	35.0	50.0	65.0
FM7-A220-□□□□-E01/E02	36.07	61.4	81.3	SPD 3.100	49.0	70.0	91.0
FM7-B120-□□□□-E01/E02	20.96	35.0	47.5	SPD 2.75	29.0	42.0	54.6
FM7-B170-□□□□-E01/E02	24.92	47.2	64.1	SPD 2.85	35.0	50.0	65.0
FM7-A300-□□□□-E01	43.20	82.1	113.2	SPD 3.150	63.0	90.0	117.0
FM7-B220-□□□□-E01	35.46	64.9	89.5	SPD 3.100	49.0	70.0	91.0
FM7-A370-□□□□-E01	35.26	89.9	127.9	SPD 3.200	84.7	121.0	157.3
FM7-B280-□□□□-E01	38.16	78.2	109.0	SPD 3.150	63.0	90.0	117.0
FM7-A510-□□□□-E01/E02	43.83	115.1	153.2	SPD 3.200	84.7	121.0	157.3
FM7-C215-□□□□-E01/E02	36.73	87.8	114.7	SPD 3.150	63.0	90.0	117.0
FM7-C270-□□□□-E01/E02	48.18	116.9	153.2	SPD 3.200	84.7	121.0	157.3
FM7-E600-C□□□-E01	53.49	117.4	150.4	SPD 3.200	84.7	121.0	157.3

Note. In many applications, it is possible to associate the FM7-A370-□□□□-E01 motor with an SPD 3.150 drive.

T. 6/14 Technical data. FM9. E01 series. Y (star) connection.

Motor	Current (Arms)			Drive Ref.	Current (Arms)		
	I_o	$I_n (S1)$	IS6-40%		$0.7 \times I_n$	$I_n (S1)$	IS6-40%
FM9-B055-C5C□-E01	39.4	104.4	146.2	SPD 3.200	84.7	121.0	157.3
FM9-B071-C5C□-E01	38.6	134.8	199.4	SPD 3.250	94.5	135.0	175.5
FM9-A100-C5C□-E01	75.2	189.9	258.2	*	*	*	*
FM9-B113-C5C□-E01	81.1	214.6	290.5	*	*	*	*
FM9-A130-C5C□-E01	106.0	246.9	338.0	*	*	*	*

* See the drive associated with the motor in the **REG. CT SERIES** manual.



FM7/FM9

Ref.1107

6.

SELECTION
Spindle drive selection

T. 6/15 Technical data. FM7. E03 series. Y (star) connection.

	Current (Arms)			Drive	Current (Arms)		
	Io	In (S1)	IS6-40%	Ref.	0.7xIn	In (S1)	IS6-40%
FM7-D055-S1D0-E03	9.8	20.3	26.2	SPD 1.35	16.1	23.1	30.0
FM7-D075-S1D0-E03	12.7	26.5	35.7	SPD 2.50	21.7	31.0	40.3
FM7-D110-S1D0-E03	18.7	38.0	50.0	SPD 2.75	29.0	42.0	54.6
FM7-D150-S1D0-E03	22.6	46.4	63.3	SPD 2.85	35.0	50.0	65.0
FM7-D185-S1D0-E03	28.5	49.2	63.0	SPD 2.85	35.0	50.0	65.0
FM7-D220-S1D0-E03	37.4	62.3	82.5	SPD 3.100	49.0	70.0	91.0

T. 6/16 Technical data. FM7. E03 series. Delta (triangle) connection.

	Current (Arms)			Drive	Current (Arms)		
	Io	In (S1)	IS6-40%	Ref.	0.7xIn	In (S1)	IS6-40%
FM7-D055-S1D0-E03	15.5	20.7	27.6	SPD 1.35	16.1	23.1	30.0
FM7-D075-S1D0-E03	19.2	25.8	34.5	SPD 2.50	21.7	31.0	40.3
FM7-D110-S1D0-E03	32.7	40.0	52.0	SPD 2.75	29.0	42.0	54.6
FM7-D150-S1D0-E03	32.7	45.7	62.3	SPD 2.85	35.0	50.0	65.0
FM7-D185-S1D0-E03	32.0	49.2	70.5	SPD 2.85	35.0	50.0	65.0
FM7-D220-S1D0-E03	44.5	61.7	86.4	SPD 3.100	49.0	70.0	91.0

T. 6/17 Technical data. FM7. HS3 series. Y (star) connection.

	Current (Arms)			Drive	Current (Arms)		
	Io	In (S1)	IS6-40%	Ref.	0.7xIn	In (S1)	IS6-40%
FM7-D075-S1D0-HS3	12.7	26.5	35.7	SPD 2.50	21.7	31.0	40.3
FM7-D110-S1D0-HS3	18.7	38.0	50.0	SPD 2.75	29.0	42.0	54.6
FM7-D185-S1D0-HS3	28.5	49.2	63.0	SPD 2.85	35.0	50.0	65.0
FM7-D220-S1D0-HS3	37.4	62.3	82.5	SPD 3.100	49.0	70.0	91.0

T. 6/18 Technical data. FM7. HS3 series. Delta (triangle) connection.

	Current (Arms)			Drive	Current (Arms)		
	Io	In (S1)	IS6-40%	Ref.	0.7xIn	In (S1)	IS6-40%
FM7-D075-S1D0-HS3	19.2	25.8	34.5	SPD 2.50	21.7	31.0	40.3
FM7-D110-S1D0-HS3	32.7	40.0	52.0	SPD 2.75	29.0	42.0	54.6
FM7-D185-S1D0-HS3	32.0	49.2	70.5	SPD 2.85	35.0	50.0	65.0
FM7-D220-S1D0-HS3	44.5	61.7	86.4	SPD 3.100	49.0	70.0	91.0

For further information on the currents of the modular SPD spindle drives and their duty cycles, see chapter 3. " Drive modules" of the "dds-hardware" servo manual.



FM7/FM9

Ref.1107

6.4 Characteristics plate

On FM7 motor models

The FM7 spindle motor series carry the following characteristics plate:

AC SPINDLE MOTOR					
8	TYPE: FM7-XXXX-XXXX-XXX	DATE: XX.XX	IP 44	12	
7	PHASE:3	POLES:4	VOLT.MAX.: 400	INS. CLASS: F	13
6	kW S1/S6-40%	X.X / X.X	RPM BASE/MAX.:	XXXX / XXXX	14
5	AMP S1/S6-40%	X.X / X.X		Fs (Hz): X.XX	15
4	Vo (V): XXX	Im (A): X.XX	R1 (Ω): X.XXX	L1 (mH): X.XX	16
3	Mounting: XX/XX	WEIGHT (kg): XX	VBR. CLASS.: XX		
2	BEARING No:	XXXXXXXXXX	XXXXXXXXXXXX		
1	SERIAL No:	XXXXXX-X-XX	ENCODER TYPE:	XXXXXXXXXX	
	Fan Motor:	V= XX/XXX	I= X.XX/XX	F = 50/60 Hz	
		FAGOR AUTOMATION S. COOP. – SPAIN Manufactured by YASKAWA ELECTRIC CORP - JAPAN NB3917-1N			

F. 6/11

Characteristics plate of the FM7 motors.

This characteristics plate of the motor is located on the left side of the motor viewed from its shaft. The items shown on this plate are:

1	Serial Nr.
2	Bearing number: Load side / fan side
3	Mounting type
4	Voltage without load
5	Rated currents in S1 / S6-40%
6	Rated powers in S1 / S6-40%
7	Nr of phases
8	Motor model reference
9	Manufacturing year/month
10	Maximum voltage
11	Stator winding resistance per phase
12	Protection degree
13	Insulation class
14	Base speed / maximum speed
15	Slip frequency
16	Stator dispersion inductance per phase
17	Level of vibration
18	Type of encoder
19	Nr of poles
20	Magnitizing current:
21	Mass
22	Fan supply voltage at 50/60 Hz
23	Fan supply current at 50/60 Hz
24	Frequency of the fan supply voltage

6.
SELECTION
 Characteristics plate



FM7/FM9

Ref.1107

6.
SELECTION
Characteristics plate

On FM9 motor models

The corresponding series of FM9 spindle motors carry the following characteristics plate:

	19				9	10	11	
	AC SPINDLE MOTOR							
8	TYPE:	FM9-XXXX-C5CX-E01	DATE:	XXXXXX	IP 54			12
7	PHASE:3	POLES:4	VOLT.MAX.:	380	INS. CLASS: F			13
6	kW S1/S6-40%:		X.X / X.X	RPM BASE/MAX.:		XXXX / XXXX		14
5	AMPS S1/S6:		X.X / X.X	Fs (Hz):		X.X		15
4	Vo (V):	XXX	Im (A):	X.XX	R1 (Ω):	X.XXX	L1 (mH):	X.XX
	Mounting:							
3	B3/B5/V1/V5/V3/V6	WEIGHT (kg):	XX	VBR. CLASS.:		V5		
2	BEARING No:		XXXX / XXXX					
1	SERIAL No:		XXXXXXXX	ENCODER TYPE:		1024 PPR		18
			FAGOR AUTOMATION S. COOP. - SPAIN					
			20	21			17	

F. 6/12

Characteristics plate of the FM9 motors.

This characteristics plate of the motor is located on the right side of the motor viewed from its shaft. The items shown on this plate are:

1	Serial Nr.
2	Bearing number: Load side / fan side
3	Mounting type
4	Voltage without load
5	Rated currents in S1 / S6-40%
6	Rated powers in S1 / S6-40%
7	Nr of phases
8	Motor model reference
9	Manufacturing year/month
10	Maximum voltage
11	Stator winding resistance per phase
12	Protection degree
13	Insulation class
14	Base speed / maximum speed
15	Slip frequency
16	Stator dispersion inductance per phase
17	Level of vibration
18	Encoder pulses per turn
19	Nr of poles
20	Magnitizing current:
21	Mass



FM7/FM9

Ref.1107

6.5 Sales reference

FM7 family

The sales reference of each motor model is determined in a set of blocks showing letters and numbers whose meaning is:

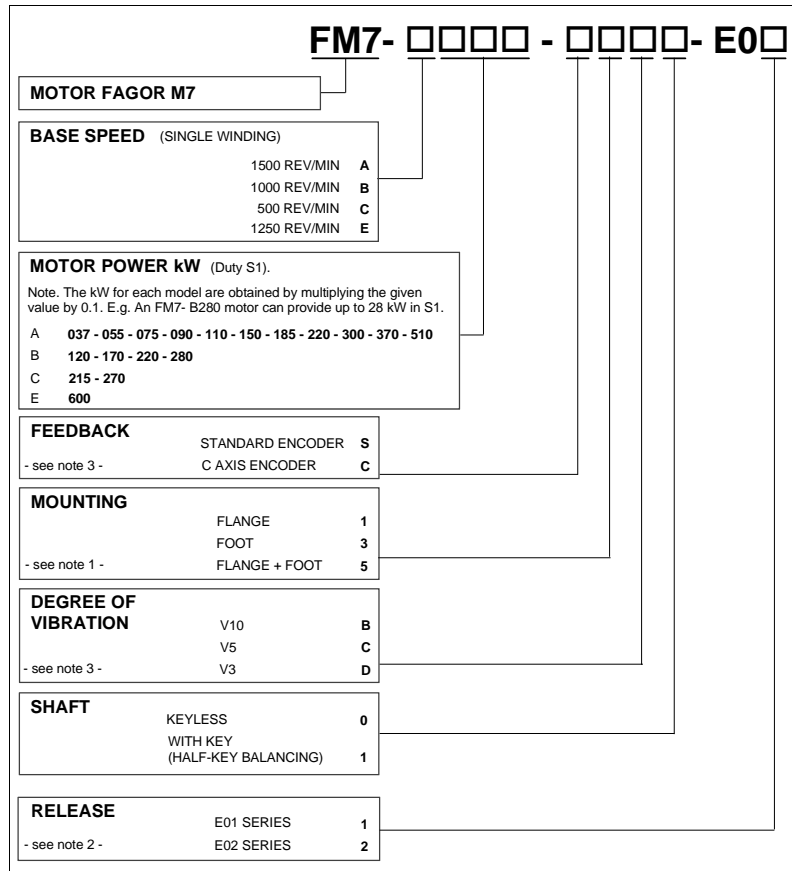

F. 6/13

FM7 motor model name. E01 and E02 series.

Note 1. The "flange + foot" mount type comes in all models except A037, A055, A075 and A090. **Note 2.** Models A300, A370, B220, B280 and E600 are not available for the E02 series. **Note 3.** E600 models can only have the C axis option for feedback and V10 vibration degree.

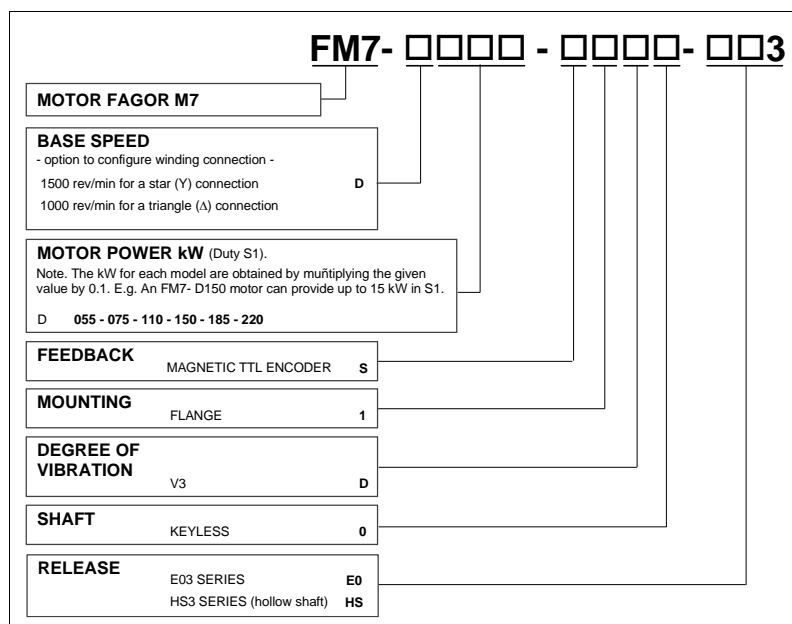

F. 6/14

FM7 motor model name. Series E03 and HS3.

The D055 and D150 models will not be available in the HS3 series.



FM7/FM9

Ref.1107

6.
SELECTION
Sales reference

FM9 family

The sales reference of each motor model is determined in a set of blocks showing letters and numbers whose meaning is:

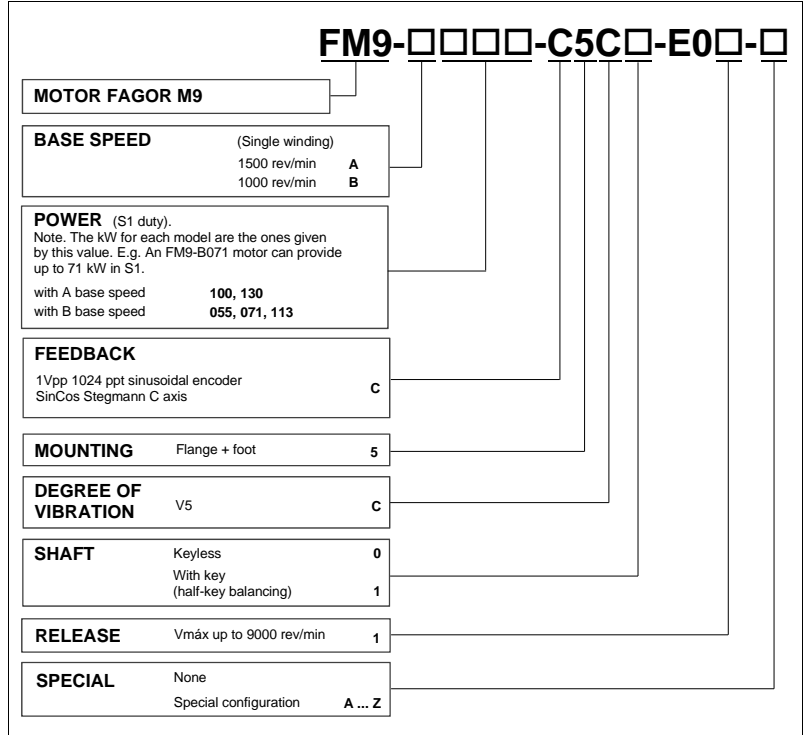

F. 6/15

FM9 motor model name. E01 series.

Special configurations.

Motor model FM9-B055-C5C□-E01-A. Smaller shaft extension diameter, 65 mm.



FM7/FM9

Ref.1107



FAGOR AUTOMATION

Fagor Automation S. Coop.

Bº San Andrés, 19 - Apdo. 144
E-20500 Arrasate-Mondragón, Spain

Tel: +34 943 719 200
+34 943 039 800

Fax: +34 943 791 712

E-mail: info@fagorautomation.es

www.fagorautomation.com

