

FAGOR HANDWHEEL MODEL: HBA-072914

Manual version: 0202
Dimensions in mm

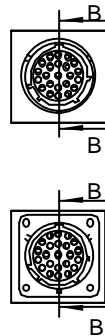
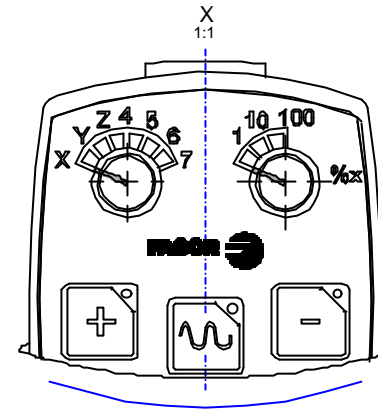
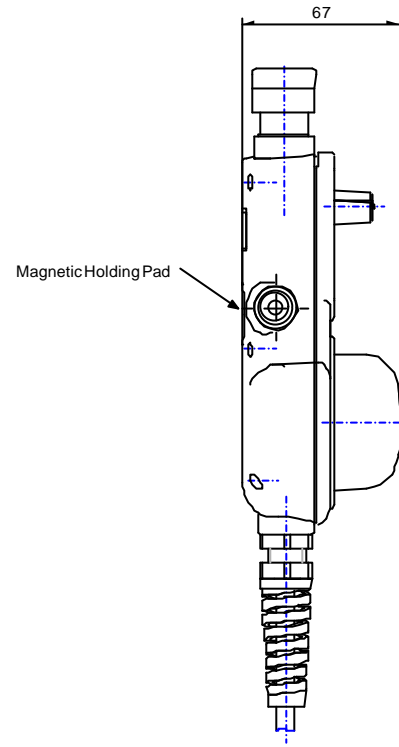
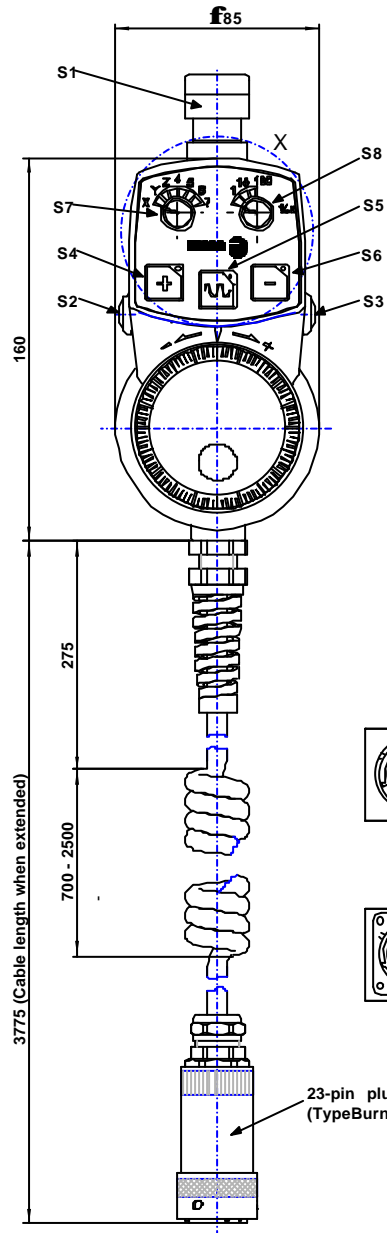

23-pin plug connector
(Type Burndy, housing material: metal)

Use for handwheel signals, shielded cable.
Connect shield to flange socket.

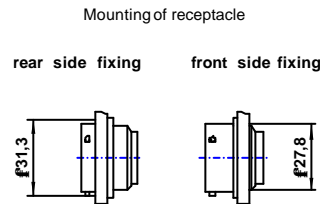

Receptacle with female contacts enclosed

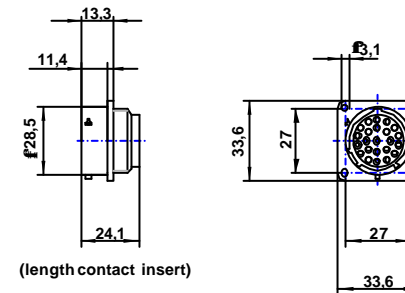

FAGOR HANDWHEEL MODEL: HBA-072914

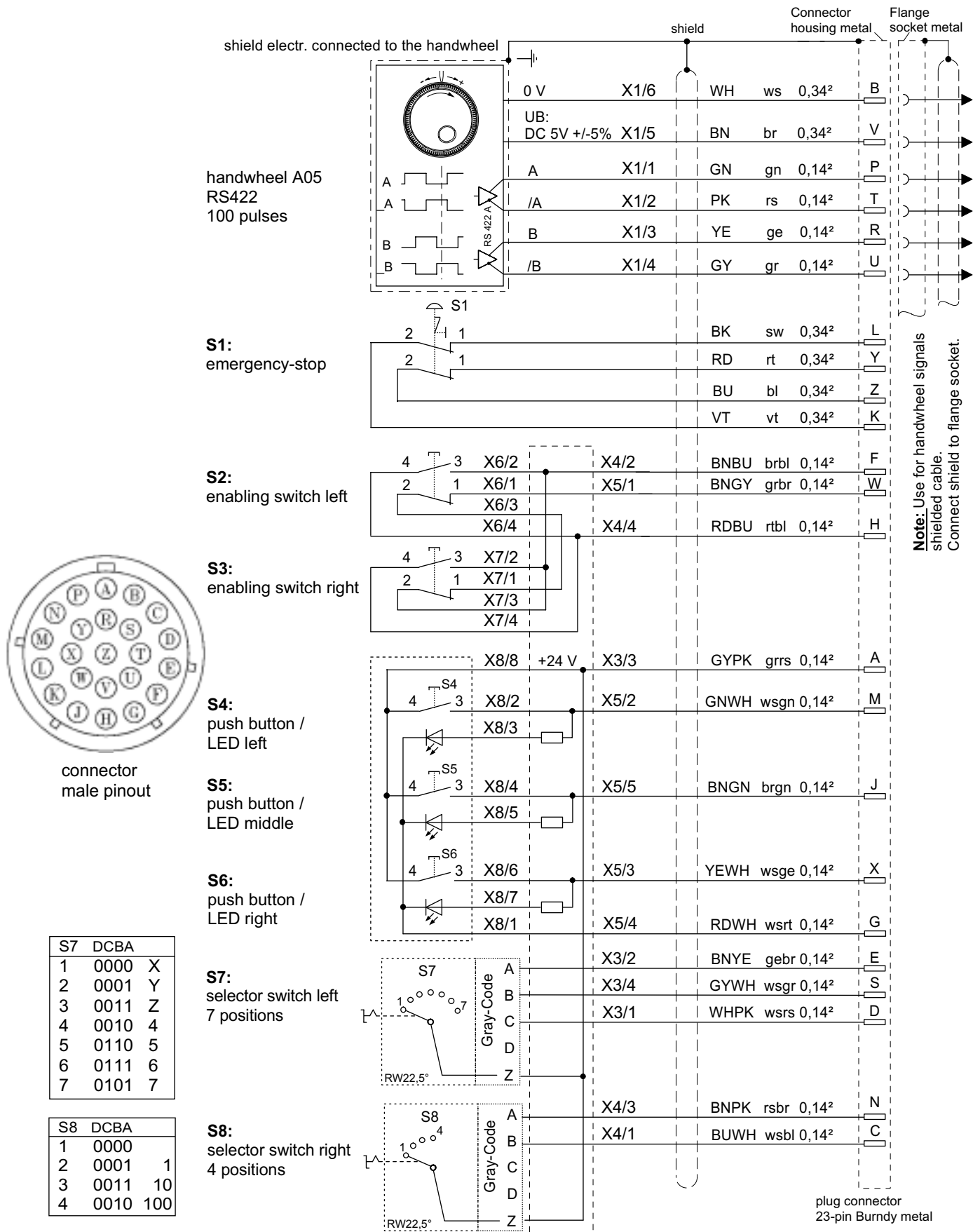

Fagor Automation S. Coop

Bº San Andrés S/N
20500 Mondragón - Spain
Tel: (+34) 943 71 92 00
Fax: (+34) 943 79 17 12
Email: info@fagorautomation.es
www.fagorautomation.com

Subject to technical modifications



FAGOR HANDWHEEL MODEL: HBA-072915

Manual version: 0202
Dimensions in mm

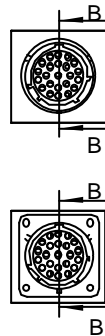
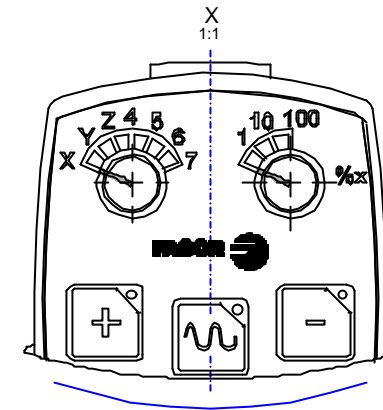
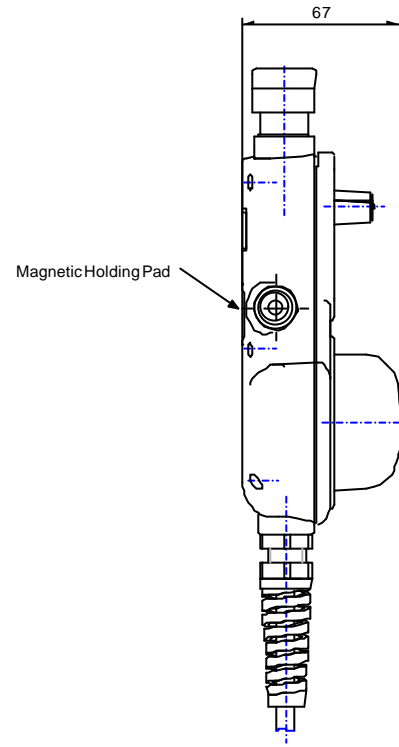
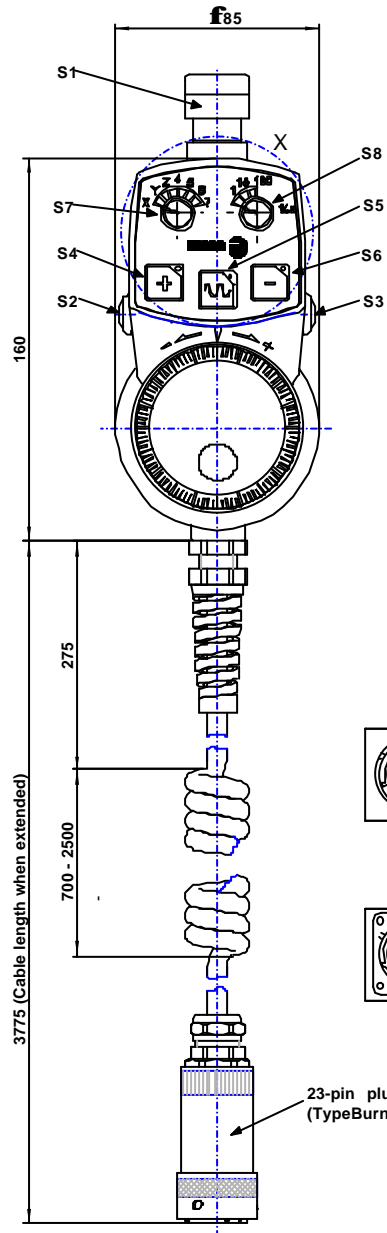

23-pin plug connector
(Type Burndy, housing material: metal)

Use for handwheel signals, shielded cable.
Connect shield to flange socket.

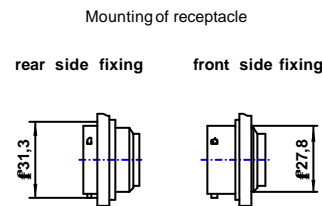

Receptacle with female contacts enclosed

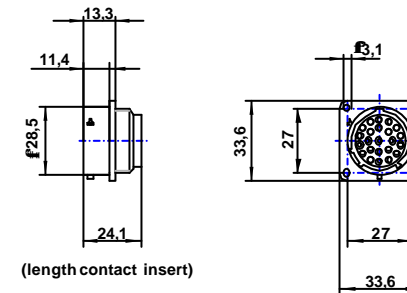

FAGOR HANDWHEEL MODEL: HBA-072915

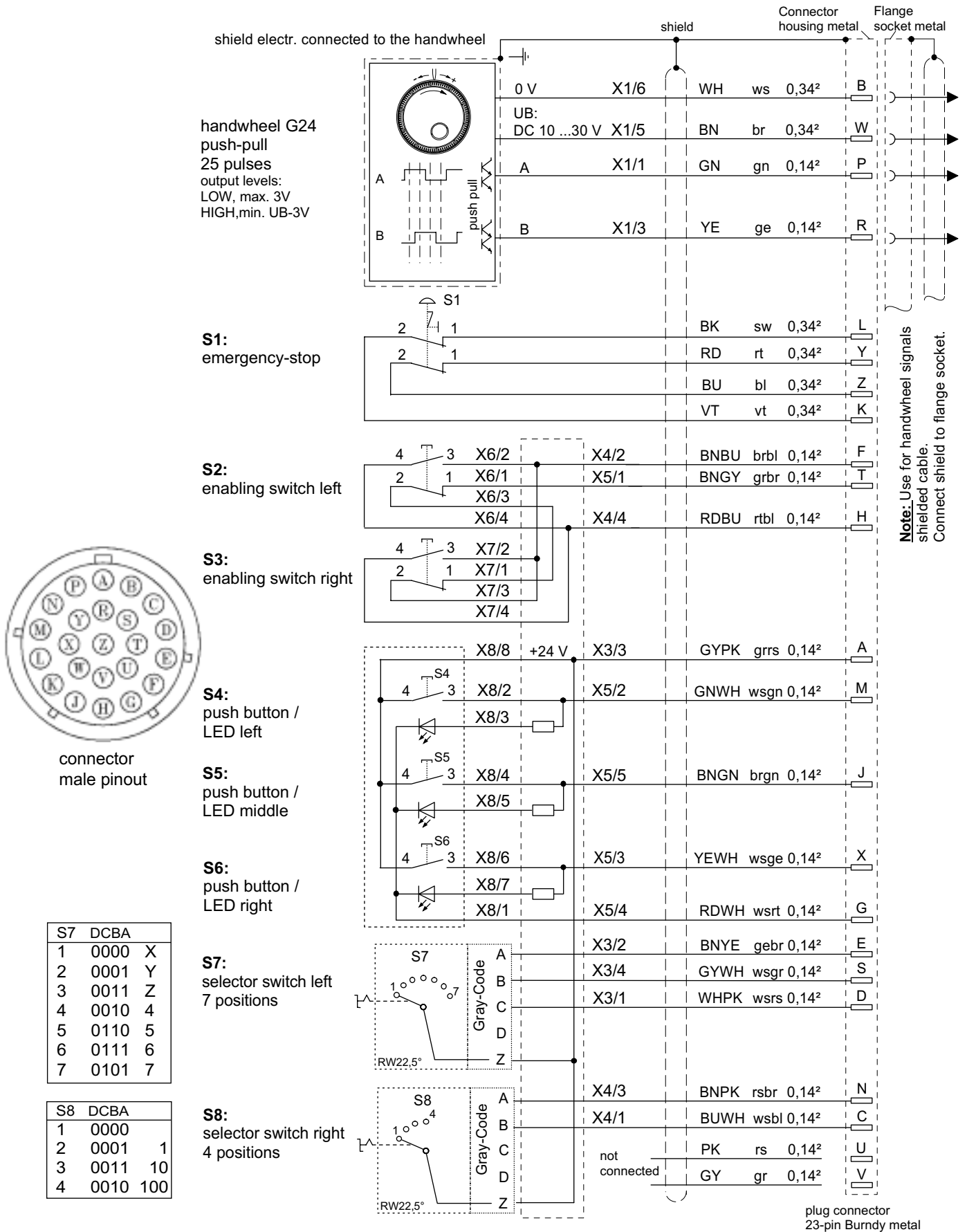

Fagor Automation S. Coop

Bº San Andrés S/N
20500 Mondragón - Spain
Tel: (+34) 943 71 92 00
Fax: (+34) 943 79 17 12
Email: info@fagorautomation.es
www.fagorautomation.com

Subject to technical modifications

